

MONTGOMERY COUNTY, MARYLAND
DEPARTMENT OF TRANSPORTATION
TRAFFIC ENGINEERING AND OPERATIONS
JUNE 2016
PEDESTRIAN UNDERPASS LUMINAIRE

1) PURPOSE

The purpose of these specifications is to provide minimum requirements for the design, manufacture, fabrication, finishing and delivery of ceiling mounted, pedestrian underpass luminaires. These luminaires are intended for use in tunnels throughout Montgomery County. Any manufacturer, distributor or vendor who submits a bid shall agree to comply with these specifications and the attached drawings.

2) DESCRIPTION

Each streetlight luminaire shall include the following:

- a) Lamp, as specified;
- b) Dropped polycarbonate refractor;
- c) All necessary hardware for ceiling mounting;
- d) “National Park Service Brown” finishing as per these specifications and attachment entitled “Finishing Galvanized Steel and Aluminum Metals.”

3) DESIGN CRITERIA

3.1) AASHTO Standards

The luminaire shall meet the requirements of the American Association of State Highway and Transportation Officials (AASHTO), “Standard Specifications for Structural Supports for Highway Signs, Luminaires, and Traffic Signals,” latest edition.

3.2) Shape and Minimum Size

The luminaire shall be square in shape. The minimum size for the luminaire shall be 22 inches (sum of the luminaire’s length plus width), when viewed from the side. The luminaire shall be of a suitable size to accommodate a 50 watt high pressure sodium vapor (HPSV) ballast and lamp.

3.3) Finish

All Visible components shall be finished to produce the appearance of a decorative “National Park Service Brown” color, as described in the attachment entitled “Finishing Galvanized Steel and Aluminum Metals.” During the finishing process, all critical openings shall be plugged to prevent contamination of the threads or reduction of critical openings.

4) MATERIALS

4.1) Design Uniformity

These Specifications are intended to produce a uniform system of hardware, that will minimize the number of stock items that the County or its contractor(s) must maintain.

4.2) Housing

The housing shall consist of a water tight shell fabricated with either welded, overlapped seams, or with extrusions sealed with silicon seals. The unit shall be completely sealed by a rubber gasket. The reflector shall be held closed with a minimum of two captive fasteners.

4.3) Material

The luminaire housing shall be completely waterproof and constructed of formed aluminum.

4.4) Castings

All castings used to complete the luminaire shall be cleaned and smooth, with all details well defined and true pattern.

4.5) Ballast

The ballast shall be mounted to facilitate easy removal and maintenance. All electrical connections shall be polarized and of plug-in design. The ballast shall be for a 50 watt HPSV bulb and shall be regulator or auto-regulator design. The ballast shall be delivered to receive nominal 120 volt AC current.

4.6) Lamp

The lamp shall be a ANSI code - S55SC-50 shall be provided (Medium Base Socket).

4.7) Reflector

The reflector shall be a one-piece dropped formed polycarbonate.

SPECIFICATIONS FOR STREETLIGHT HARDWARE

IFB # 1063092

SPECIFICATIONS FOR STREETLIGHT HARDWARE

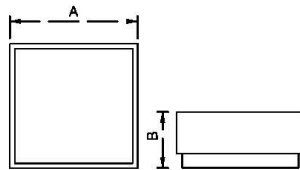
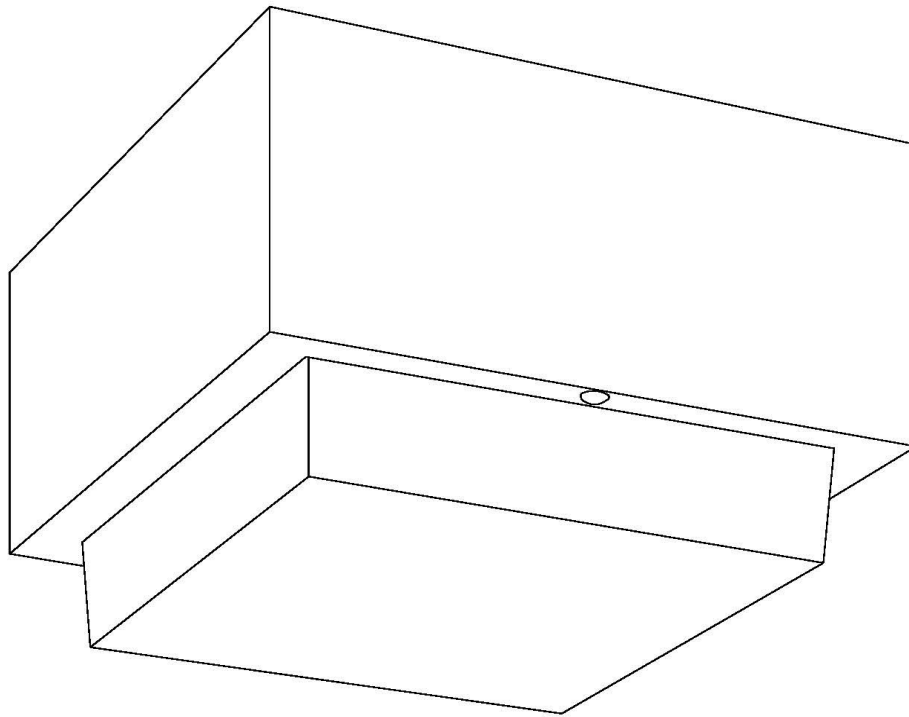

A	B	WEIGHT
14" SQ.	8"	20 lbs.
356 mm	203 mm	20 lbs.