



Montgomery County Department of Transportation
Division of Traffic Engineering and Operations

COMMUNITY DISCUSSION PAPER

DETERMINATION OF ACCESS RESTRICTION ELIGIBILITY

Leland Street

Prepared in cooperation with Mead & Hunt, Inc.

Executive Summary

The results of a data collection effort and technical analysis confirm the following findings:

- In December of 2019 the Hamlet Citizens' Association requested access restrictions for eastbound and westbound traffic in accordance with Executive Regulation 17-94AM.
- In March of 2022, traffic counts, for both traffic volume and speed, were conducted. Based on the volumes collected, in March of 2022, anonymized license plate data was collected in the westbound morning peak hour to determine the degree of cut-through traffic. The license plate data was further processed to determine the block location of the registered vehicles in order to map the origin of the drivers along Leland Street.
- In May 2022, a Community Discussion paper was drafted based on the data collection effort and analysis, in conjunction with Executive Regulation 17-94AM. Per Executive Regulation 17-94AM, Leland Street meets the County's requirements for access restrictions per in the AM peak hour.
- The recommended access restriction is:
Installation of a regulatory sign to restrict southbound right turns from MD 186 to Leland Street from 7:00 – 9:00 AM, with plaque to include "except buses" to account for Ride-On bus and service and school buses.
- This restriction will prohibit all local and non-local traffic from entering Leland Street from southbound MD 186 in the AM peak period. Based on a traffic analysis of the study area intersections that would see modified traffic patterns from diverted traffic, this access restriction was not found to significantly impact adjacent roadways or intersections.

1. INTRODUCTION

Executive Regulation 17-94 “Through Traffic Volume Access Restrictions in Residential Areas” was authorized to aid in the County’s efforts to “enhance neighborhood traffic safety and maintain ‘livable’ residential environments by providing a procedure for reducing excessive volumes of through traffic.” The policy attempts to balance the needs of all impacted parties while maintaining the efficient and appropriate use of County streets and public rights of way.

The Department of Transportation assists communities in developing a Through Traffic Volume Management Plan by designing and evaluating the impacts of access restrictions. The Department then reports its preliminary assessment in a “Community Discussion Paper (CDP)”, which will serve as the basis for discussions with residents and other potentially impacted parties. The purpose of this CDP is to determine access restriction eligibility for the Hamlet community, as well as evaluate proposed access restrictions.

2. REGULATORY PROCESS

The development of, criteria for, public comment on, and approval process for installation of access restrictions in residential areas follows seven sequential steps:

1. **Application & Eligibility:** The process begins with an initial request for access restrictions and determination of street eligibility for access restrictions
 - Application - A request for neighborhood through traffic volume restrictions may be made by a local citizens Association which represents a significant number of residents or by a petition from 15 percent of the households in an area being proposed for traffic restrictions.
 - Eligibility - The Department will assess the area described in the application and adjust boundaries as appropriate to delineate the traffic shed. Eligibility of one or more streets in a residential area for volume restrictions must be based on satisfying criteria for:
 - Functional classification of the study roadways
 - Measured traffic volumes
 - Estimated non-local traffic
2. **Project Development:** Once eligible, the Department will move forward to develop a detailed plan and assess the potential traffic impacts of that plan.
 - Preliminary Plan – input from the community will be solicited and considered in developing a detailed plan to manage through traffic volumes on eligible streets within a traffic shed or volume management area. The plan may include traffic controls such as signs and pavement markings or other physical barriers that establish turn or entry restrictions, one-way traffic flows, or mandatory turns. Speed reduction measures such as speed humps, chokers, roundabouts, etc. and pedestrian improvements such as sidewalks are addressed under other processes established by the Department. Under no circumstance may a street be fully closed to traffic.
 - Community Discussion Paper – A formal study typically including 1) technical and quantitative analysis of existing traffic conditions such as traffic volumes, travel times, origin-destination

surveys, 2) the development of a plan for implementing one or more access restriction measures, and 3) the assessment of potential consequences of such actions on:

- the surrounding residential streets that may receive diverted traffic
- the surrounding collector, arterial and highway network that is intended to carry through traffic volumes
- potential impacts on access to public facilities such as schools, parks and libraries located within the traffic volume management area
- compatibility with Master and Sector Plans

3. Community Assessment: Once a Preliminary Plan and Community Discussion Paper have been completed, disclosure and public dialogue and access to information for a minimum of 30 days. Stakeholders for the Plan may include the following groups:

- Community Associations
- Business Associations
- Local Municipalities (e.g., Town of Chevy Chase)
- Schools
- Hospitals
- Other County Agencies (e.g. Department of Recreation, M-NCPPC)

Means of communication the Department may undertake with stakeholders may include any or all of the following:

- Public Notification
- Working Groups
- Advisory Committee

4. Final Plan: Based on the feedback received during the Community Assessment phase, the preliminary plan may be revised by the Department to address concerns and a Final Plan will be produced.

5. Public Hearing: Within 60 days of submitting a Final Plan, a public hearing will be held, with ample (15 days) notice and hearing announcements posted, and a hearing officer will decide on behalf of the Executive whether to support the plan. In deciding whether to create an area and adopt a plan for that area, the Executive must consider:

- the classification or function of each street in the area and existing street widths;
- overall traffic volumes and level of use by non-local traffic;
- pertinent traffic and pedestrian safety factors;
- the impact of possible traffic flow restrictions on nearby residential areas, businesses, public access and facilities, and the surrounding street network;
- feasibility of compliance and enforcement;
- the need of the residents in the proposed area for traffic flow restrictions;
- approved or pending master or sector plans; and
- any other factor the Executive finds relevant. The Executive must not reject a proposed plan primarily because it would increase traffic volumes on arterial roads.

In summary, the Executive must decide if the benefits of the Plan outweigh the possible impacts to the surrounding community, higher functioning roadways, or other resources. However, the Executive does have discretion to request specific modification to the Plan to better balance the goals of the plans with the potential consequences of access restrictions.

6. **Adaptation:** Once the plan is recommended by the Executive for implementation, the applicant will be asked to collect a petition from determined eligible properties (one adult signature per property) to move forward. A simple majority (51% or more) will be required to adopt the Plan; a non-response will be considered a no vote.
7. **Implementation and Assessment:** Once adopted, passive measures will be scheduled for installation by Department forces. In cases where physical measures have been recommended, funding for construction may be submitted through the County's Capital Improvement Program.

After a period of a minimum of 90 days, the Department may conduct an 'after' assessment to document actual changes in traffic patterns.

3. GLOSSARY OF TERMS

Definitions for common terminology used in this report are presented below.

Access Restriction – A full or part-time regulatory prohibition or physical barrier preventing full or directional entry into or through a particular street.

Arterial – A roadway that functions primarily to facilitate high volume vehicular traffic connections between, collector streets and major thoroughfares such as expressways and freeways; and secondarily to provide access to abutting land uses.

Average (Weekday) Daily Traffic (AWDT) – The average total number of vehicles in one or more direction of travel in a 24-hour (weekday) period passing a given point on a roadway.

Collector – An intermediary street that funnels vehicular traffic to and from local streets and arterials, providing moderate access to adjacent land uses.

Community Association - Any incorporated or unincorporated common ownership or Civic Association which represents the interests of the subdivision in which the street being considered for access restrictions is located.

Community Discussion Paper – A formal study typically including 1) technical and quantitative analysis of existing traffic conditions such as traffic volumes, 2) the development of a plan for implementing one or more access restriction measures, and 3) the assessment of potential consequences of such actions.

Cut-through or Non-local traffic – Through traffic diverted from arterial and collector streets onto local residential streets to avoid congestion and/or longer trips, with both an origin and destination external to

the neighborhood and/ or traffic shed boundaries as documented in a license tag survey sample or other appropriate measure. Note that vehicles which cross a collector or arterial road from an originating local street, and continue to another local street in the same destination direction of the collector/arterial road, without a destination on that local street, may be considered part of the non-local traffic in some cases depending on the exact boundaries of the traffic volume management area.

Functional Classification – Is the process by which streets and highways are grouped into classes, or systems, according to the character of traffic service that they are intended to provide. There are four highway functional classifications: highway, arterial, collector, and local roads. All streets and highways are grouped into one of these classes, depending on the character of the traffic (i.e., local or long distance) and the degree of land access that they allow.

Major Highway – A roadway with limited or controlled access that carries high through traffic volumes between freeways, central business districts and other major traffic generators. Major highways provide a high level of traffic service and a low level of direct access to local development.

Management Plan – That group of traffic controls, which may include signs, pavement markings, and physical devices or barriers, designed to reduce, divert, or discourage non-local traffic in a particular neighborhood or on a particular neighborhood street.

Neighborhood Traffic Committee – An ad hoc group of residents formed in the absence of an active Community Association which represents the interests of the subdivision in which the street being considered for speed humps is located.

Residential Street – A neighborhood street providing direct access to abutting residential land uses, not intended to service traffic traveling beyond or through a neighborhood. Residential streets can be sub classified as follows:

- Primary Residential Street: A neighborhood street serving as a collector for local traffic from secondary and tertiary residential roadways, designed to feed traffic to arterial and major highways. Primary roadways provide a moderate level of traffic service and a high level of direct residential property access. Can also be defined as a Master Plan primary street so designated in a Master or Sector plan.
- Secondary residential street – A neighborhood street providing a high level of direct residential access and a limited level of traffic service; not intended to provide for traffic traveling through the neighborhood.
- Tertiary residential roadway – A neighborhood street with similar function to a secondary street but having a narrower right-of-way and typically ending in a cul-de-sac.

Study Intersections/ Study Area – A geographic area which includes all critical intersections along arterials or major highways that connect to each other or local collector and residential streets within the traffic shed or traffic volume management area and which may need to be analyzed to determine potential impacts of access restrictions.

Traffic Shed – A geographic area defined by an interconnected network of local primary, secondary and tertiary streets within a neighborhood or portion of a neighborhood that feed into the same arterials or major

Traffic Volume Management Area – An area defined by natural or physical/ transportation boundaries, typically encompassing one or a portion of a neighborhood or traffic shed, within which residents, businesses and other visitors may be required to change their travel patterns to reach a local origin or destination within the traffic volume management area with the implementation of access restrictions on one or more streets.

85th-Percentile Speed – The speed at or below which 85% of the vehicles are moving. 85th-percentile speed is a common measure of the speed at which most motorists consider safe and reasonable based on the prevailing geometric and traffic conditions on a particular roadway. Studies have demonstrated that drivers who travel either slower or faster than the 85th-percentile speed of the traffic stream have a higher rate of crash involvement rate than those drivers whose speed is close to the 85th-percentile speed. The measured 85th-percentile speed indicates that only 15% of drivers exceed it.

4. STUDY AREA LOCATION AND PURPOSE

A. Study Area

Residents of the Hamlet Community in Montgomery County, MD state that non-local drivers are using Leland Street during commuter rush hours. Residents believe this cut-through traffic is using local neighborhood streets to avoid congestion and delays on MD 185, MD 186, and MD 410.

Definitions of key areas for this study are as follows:

- The Traffic Shed is bounded by MD 185, MD 410 and MD 186.
- The Traffic Volume Management Area is defined as MD 410 (East-West Highway), MD 186 (Brookville Road), St. Lawrence Drive, Leland Street, Glendale Road, and Curtis Street.
- Study Intersections will include all abutting intersections along MD 410 and MD 186 as well as Bradley Lane and Leland Street.

A map of the traffic shed and traffic volume management area is shown in **Figure 1**.

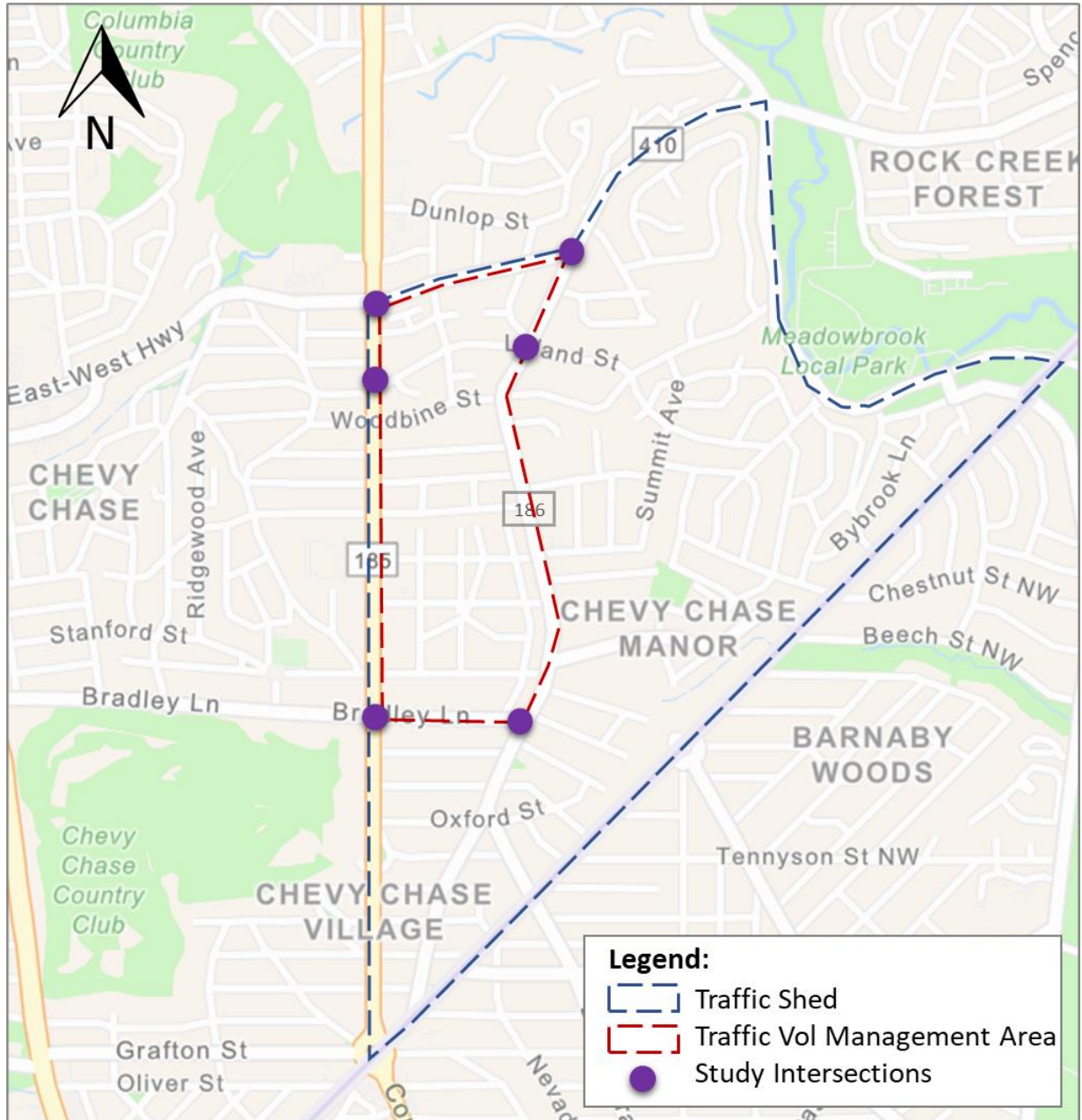

FIGURE 1: STUDY AREA MAP

B. History

The neighborhood has noted that the excessive cut-through traffic through the Hamlet neighborhood has negatively impacted the quality of life and safety of residents. This is potentially due to increasing regional traffic volumes, as well as recurring congestion along MD 185 and MD 410. Motorists may perceive it is faster to cut through the neighborhood than to remain on the State highways.

C. Location

The study area is situated on the southeast corner of MD 185 and MD 410 and bounded by MD 186 to the east, thereby, nestled between three State roadways under the Maryland State Highway’s (SHA) jurisdiction. The neighborhood is comprised of county-maintained roads. An area map is shown in **Figure 2**.

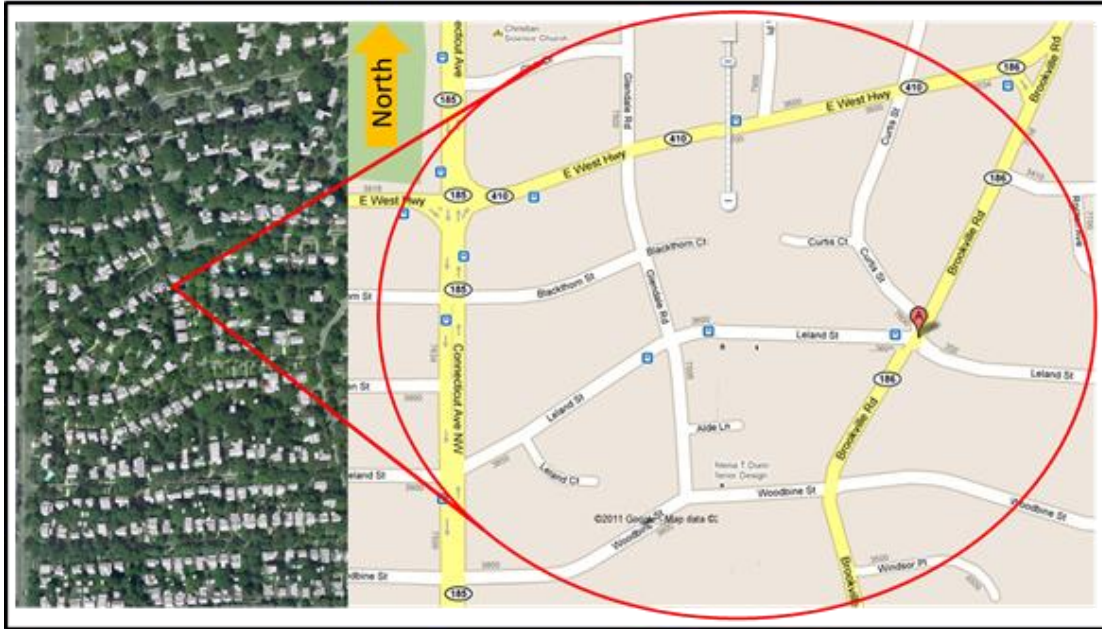

FIGURE 2: LOCATION MAP (NOT TO SCALE)

D. Purpose

The purpose of the study is to document the volume of non-local through traffic utilizing the study roadways to avoid congestion on MD 185 (Connecticut Avenue), MD 410 (East-West Highway) and MD 186 (Brookville Road), and, if eligible, develop and implement an access restriction plan after evaluating the potential impact of that plan on the roadway network and community. This paper summarizes the results of a technical analysis including existing conditions, traffic volumes, capacity analysis, license plate surveys, travel time, and field observations.

5. EXISTING CONDITIONS ANALYSIS

A. Roadway Network, Land Use, Community Resources and Existing Restrictions

The following section describes the study area roadway network and its characteristics, existing land use mixture, community resources such as public spaces, and vehicular access restrictions that are already in place.

The Montgomery County Master Plan of Highways classifies MD 185 (Connecticut Avenue) and MD 410 (East-West Highway) as major highways. MD 186 (Brookville Road) is classified as a primary residential. MD 185 is a six-lane divided roadway between the District of Columbia and mid-Montgomery County. The speed limit along MD 185 within the study area is 30 miles-per-hour (mph); there are three traffic signals along MD 185 within the study section. MD 410 is an undivided four-lane roadway between Prince George’s County and Bethesda. The speed limit along MD 410 within the study area is 35-mph. MD 186 is a two-lane roadway between MD 410 and Western Avenue with a posted speed limit in the study area of 25-mph.

The Chevy Chase Master Plan classifies Leland Street as a secondary residential road. It should also be noted that the properties sited on Leland Street as bounded by Turner Street and Curtis Street and Alden Lane fall within Chevy Chase Section 5.

Bus stops for the Ride On Route 1 bus are located along Leland Street at Glendale Road and at MD 186.

The Route 1 bus has peak-hour service Monday through Friday and weekend service. The public Ride On bus Route 11, and Washington Metropolitan Area Transit Authority (WMATA) Routes J2 run east-west along MD 410.

Land uses within the study area are exclusively residential. The designated schools, Chevy Chase ES and Rosemary Hills ES, Westland MS, and BCC High School are all located outside of the community. A Fire Station and Library are located north of the study area along MD 185. A Country Club is located adjacent to the MD 185 / MD 410 intersection (Northwest quadrant). There is one local commercial strip with a coffee shop along MD 186 south five blocks south of Leland Street between Turner Street and Summit Avenue.

There are many **traffic control restrictions** via signage or geometrics within the defined traffic volume management area. The **Existing traffic restrictions** and controls for the Hamlet community include:

- Left turns along MD 185 northbound are prohibited at streets south of MD 410, while right turns are prohibited southbound between 7:00 – 9:00 AM.
- Along westbound MD 410 right turns are restricted between MD 186 and MD 185, while left turns are prohibited at MD 410 westbound at Glendale Road between 7:00 - 9:00 AM and 4:00 – 6:00 PM.
- “No Thru Trucks Signs” are posted for the streets north of MD 410 and westbound movements from MD 186 to Curtis Street, Leland Street and Williams Lane.
- “Do Not Enter Signs” are posted for streets west of MD 185 from 7:00 – 9:00 AM.

A detailed map of all access restrictions is shown in **Figure 3** on the next page.

Existing traffic calming:

- Traffic calming measures within the study area are limited to speed tables along Leland Street, Taylor Street, Shepherd Street, Raymond Street, and Bradley Lane between MD 186 and MD 185.



OPERATOR02430 - PLOT1D: 10/22/2020
FILE NAME: \2017\46 Montgomery County No. 1009764 Traffic Engineering and Operations_Group_1_Prima\Task 24 Leland Road Access Management\img\leandst.jpg

FIGURE 3 EXISTING ACCESS RESTRICTIONS

B. Traffic Volumes

Peak hour intersection traffic data for the study area intersections was gathered from the Maryland State Highway Administration (MDSHA), Maryland-National Capital Park and Planning Commission (MNCPPC) and supplemented with new data collected as a part of this study. The new volume data was collected at Leland Street at MD 185 and at MD 186 on March 30, 2022. To accurately depict traffic volumes from different sources and times, Figure 4 illustrates peak hour *balanced* volumes at study intersections. Detailed traffic data is included in Appendix A. Table 1 summarizes the most conservative volumes for the weekday AM and PM peak hour bi-directional traffic volumes along the study roadway segments.

TABLE 1: PEAK HOUR BI-DIRECTIONAL TRAFFIC VOLUMES - AM (PM)

Roadway	Westbound/ Northbound	Eastbound/ Southbound	Total Peak Hour Volumes	Total Daily Volume
Leland Street: between MD 186 and Glendale Rd	142 (52)	34 (42)	176 (94)	1,158
MD 410: 0.10mi east of MD 185	880 (720)	509 (1098)	1,389 (1,818)	18,412
MD 185: 0.10mi south of MD 410	1,536 (1,699)	1,889 (1,534)	3,425 (3,233)	41,083
MD 186: 100ft south of Leland St	168 (551)	725 (279)	893 (830)	6,423

The total volume of traffic on Leland Street is less than 100 vehicles per hour during the PM peak hour and does not meet the minimum threshold for eligibility of access restrictions; therefore, this study will focus on evaluating cut-through and access controls during the morning peak period only.

FIGURE 4: EXISTING VOLUMES DIAGRAM

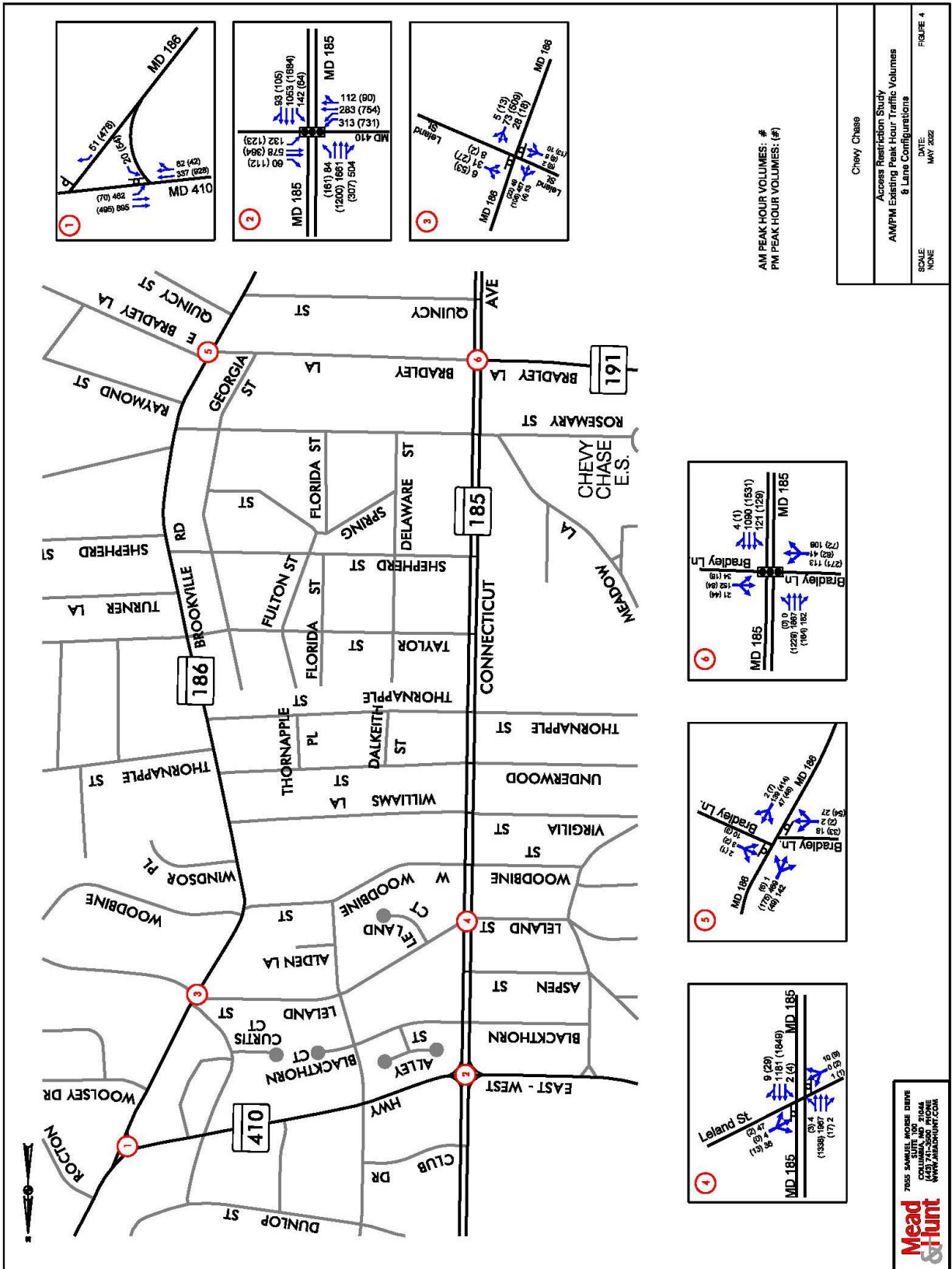

C. Capacity Analysis

The Critical Lane Volume Analysis (CLV) methodology was used to evaluate capacity and level of service for the selected intersections during the AM and PM peak hours. Performance measures of effectiveness include critical lane volume, volume-to-capacity ratio, and level of service.

The critical lane volume for each peak period is found by combining the critical lane volumes for the NB/SB movements and EB/WB movements. The critical lane volumes indicate the highest volume for a given approach lane configuration in each direction. The volume-to-capacity ratio (v/c ratio) is the ratio of current flow rate to the capacity of the facility. This ratio is often used to determine how sufficient capacity is on a given roadway. Generally, a ratio of 1.00 indicates that the roadway is operating at capacity. A ratio of greater than 1.00 indicates that the facility is failing as the demand of vehicles exceed the intersection's available capacity.

The level of service (LOS) is a letter designation that corresponds to a certain range of roadway operating conditions. The levels of service range from A to F, with A indicating the best operating conditions and F indicating the worst, or a failing, operating condition. Level of service thresholds are summarized in Table 2, the results of the capacity analyses are summarized in Table 3. Detailed capacity worksheets for existing conditions are included in Appendix B.

TABLE 2: CRITICAL LANE VOLUME LEVEL OF SERVICE PARAMETERS

LOS	Volume (CLV)	Expected Problems at Intersection
A	≤ 1000	Very low delay
B	> 1000 and ≤ 1150	Short delay
C	> 1150 and ≤ 1300	Number of vehicles stopping is significant
D	> 1300 and ≤ 1450	Influence of congestion becomes noticeable
E	> 1450 and ≤ 1600	Limits of capacity, moderate to excessive delay
F	> 1600	Oversaturated traffic conditions, excessive delay

(Source: MD State Highway Administration.)

TABLE 3: CAPACITY ANALYSIS SUMMARY TABLE

Intersection	Critical Lane Volume	Volume-to-Capacity Ratio	Level of Service
MD 410 at MD 186	693 (992)	0.43 (0.62)	A (A)
MD 410 at MD 185	1469 (1514)	0.92 (0.95)	E (E)
Leland St at MD 186	670 (652)	0.42 (0.41)	A (A)
Leland St at MD 185	831 (721)	0.52 (0.45)	A (A)
Bradley Ln at MD 186	718 (618)	0.45 (0.39)	A (A)
Bradley Ln at MD 185	1346 (1376)	0.84 (0.86)	D (D)

D. Non-Local Traffic

A license plate survey was performed in March 2022 to determine the percentage of cut-through traffic along Leland Street between Glendale Road and MD 410. The purpose of the license plate study is to determine the percentage of non-local traffic currently utilizing the neighborhood streets, i.e. those vehicles without either an origin or destination within the defined traffic shed. The evaluation was conducted by recording license plate data in the field and then entering them into a database to perform a record search of the vehicle’s registered address.

Based on one hour (8:00 AM – 9:00 AM) of morning data the following was found:

In the morning hour of 8:00 AM – 9:00 AM it was reported that of 39 vehicles entering Leland Street from MD 185, 35 were local and 51 were non-local (59%).

Table 4 below illustrates the license plate study vehicles survey and the resultant percentage of traffic determined to be cut-through. A map showing the address of the vehicles surveyed is showing in

TABLE 4: LICENSE PLATE SURVEY

Location	Date	Time	Within 1-mile Boundary	Outside 1-mile Boundary	Total Vehicle with Available Lic. Plate Info.	Remarks
Leland Street between Glendale Rd and MD 186	3/31/2022	8-9 AM	35	51	86	= 59% >50% Cut Through Traffic. Meets Criteria

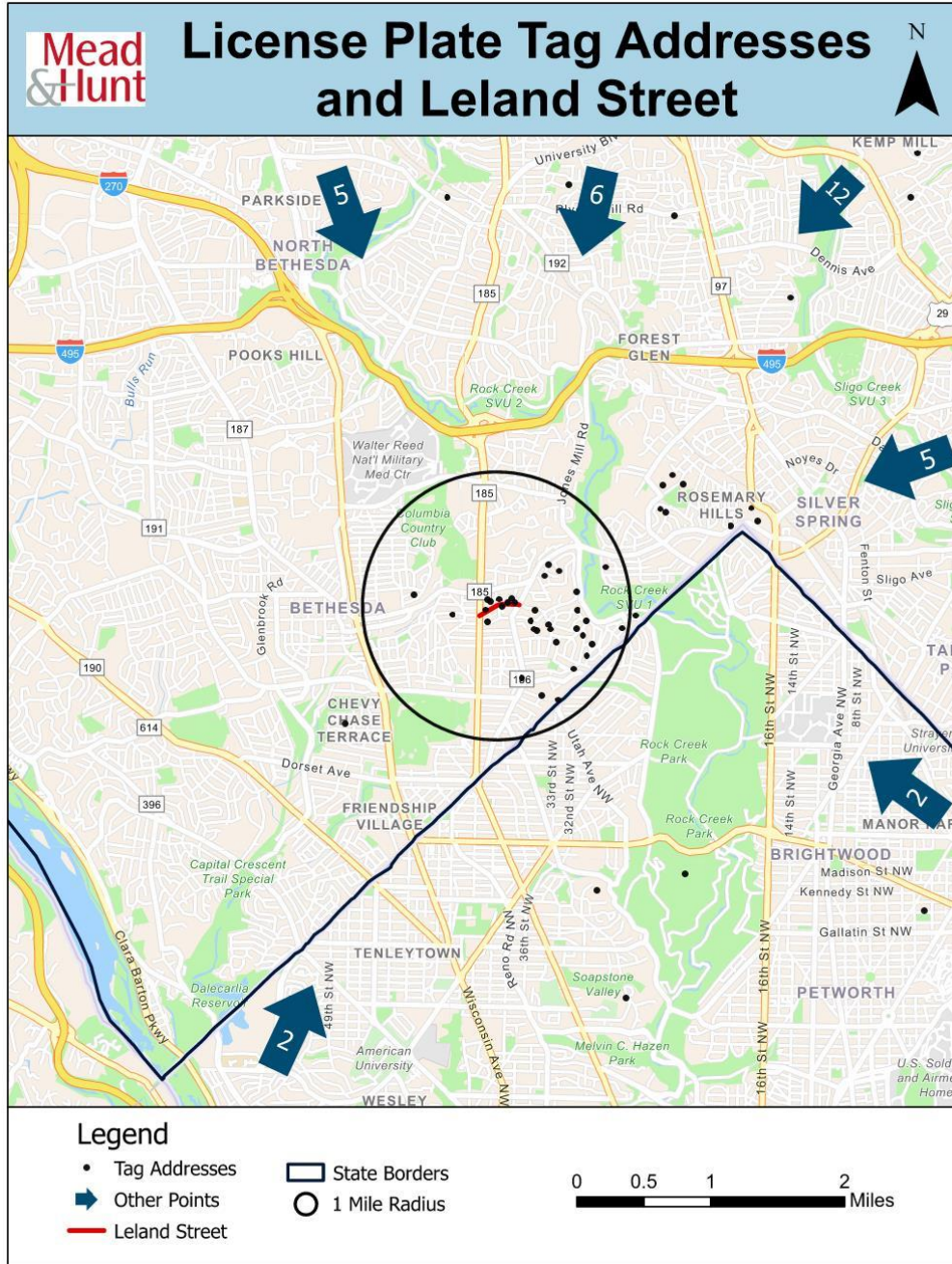

FIGURE 5: LICENSE PLATE SURVEY MAP

E. Travel Time Analysis

Detailed field investigations of travel times along Leland Street, and adjacent primary roadways were performed during a typical midweek day (March 31, 2022) during the AM (7:00 – 9:00) peak hour, while school was in session. The purpose of this analysis is to document relative travel times, including delay at signalized intersections, over routes that diverted traffic may experience if access restrictions were implemented along Leland Street and MD 186 to/from Hamlet’s Leland Street and Glendale Road. Five (5) travel time runs were conducted for Routes 1 and 2 listed below. The starting and ending points were the

same for each route and compare the Leland Street cut-through route with the same trip using the primary route of MD 410. Figure 6 shows the travel time run paths for routes 1 and 2. Table 5 shows a summary of the average travel times recorded during the AM peak hours. Detailed travel time information for each route can be found in Appendix C.

- Route 1 (Southwest-bound Baseline): In the morning (7:00 – 9:00 AM) from MD 410 at Twin Forks Lane; westbound along MD 410 to the intersection of MD 410 and MD 185; left to southbound MD 185 to MD 185 at Underwood Street. The average duration of the Baseline route in the AM is 6 minutes and 5 seconds.
- Route 2 (Southwest-bound Leland St): In the morning (6:00 – 9:00 AM) from MD 410 at Twin Forks Lane; westbound along MD 410 to the intersection of MD 410 and MD 186; left to southbound MD 186 to MD 186 at Leland Street; right to westbound Leland Street to Leland Street at MD 185; left to southbound MD 185 to MD 185 at Underwood Street. The average duration of the Leland Street route in the AM is 4 minutes and 8 seconds.

TABLE 5: SUMMARY OF AM TRAVEL TIME ROUTES

Route Number	Direction	Route Description	Travel Time
1	Southwestbound	MD 410	6:05
2	Southwestbound	Leland Street	4:08

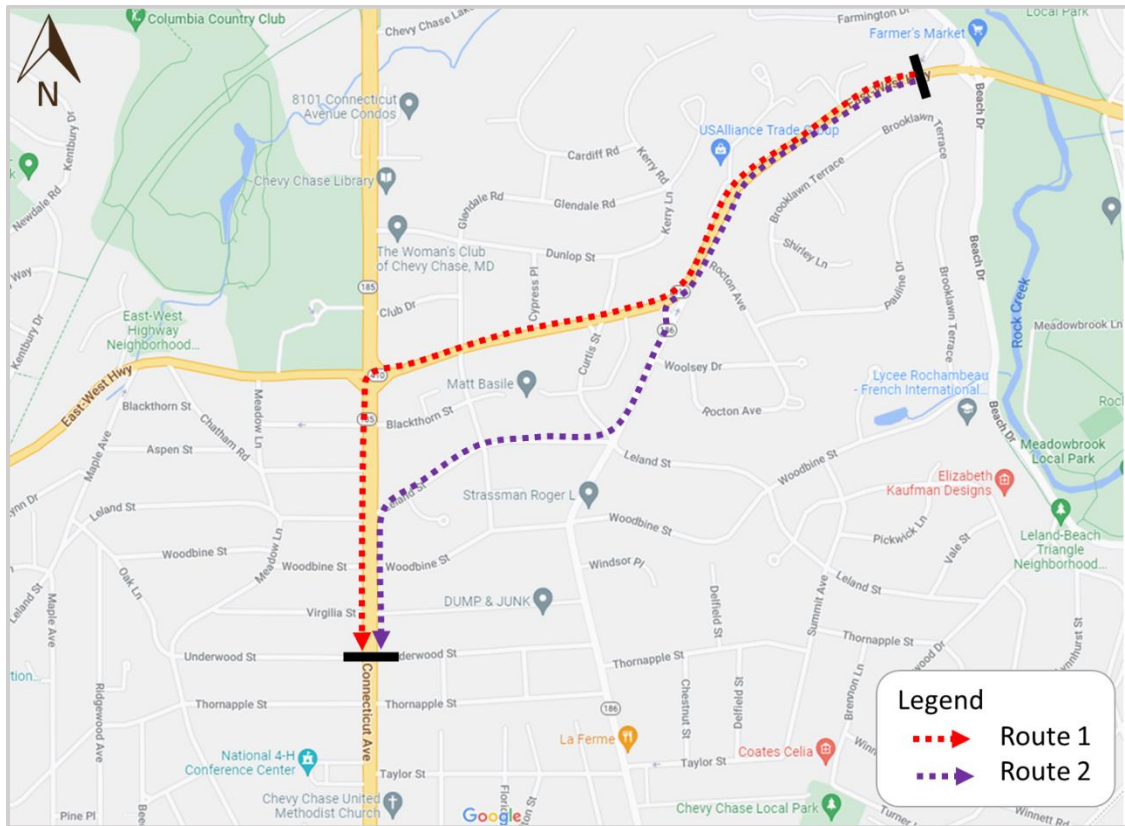

FIGURE 6: AM TRAVEL TIME ROUTES

It can be noted that all routes along neighborhood streets, shown in Figure 6, are primarily shorter than the Baseline route. Findings indicate that typically the baseline route, MD 410, has the highest travel time thus affirming the desire to cut-through using Leland Street.

F. Field Observations

A Professional Traffic Engineer observed the study area in March 2022 on a weekday during the morning peak, specifically focusing on driver behavior, traffic patterns and queues, geometry, and overall traffic operations. The following summarizes the observations:

- Heavy westbound traffic was present at the MD 410 at MD 185 intersection. Queues stretching back to MD 186 were observed along with multiple cycle failures (e.g. not all westbound vehicles along MD 410 queued at the MD 185 intersection able to clear during one green signal indication). One driver in such a queue was observed making a U-turn to cut through the neighborhood;

6. ACCESS RESTRICTION ELIGIBILITY ANALYSIS

According to Executive Regulation 17-94AM, the eligibility requirements and satisfaction thereof are summarized below in Table 6. The evaluation focuses on Leland Street.

TABLE 6: SUMMARY OF LELAND STREET ACCESS RESTRICTION ELIGIBILITY ANALYSIS

Criteria	Description	Hamlet Existing Condition	Satisfied?
Street Classification	Access volume restrictions limited to tertiary, secondary, and primary residential streets.	All of the study streets in Hamlet community are classified as secondary residential streets.	Yes
Measured Traffic Volumes	A minimum two-directional volume: > 400 vehicles per hour for at least one hour of a weekday peak or off-peak time period on a primary street with one unobstructed travel lane in each direction. > 250 vehicles per hour on a non-primary residential street with one unobstructed travel lane in each direction. > 100 vehicles per hour on any residential street with one unobstructed travel lane serving both directions.	Based on the secondary residential roadway classification, the measured traffic volumes exceed the 100 total two-way volume per hour on Leland Street.	Yes
Estimated Non-Local Traffic	Non-local traffic must exceed 50 percent of the highest hourly volume, as documented by a license plate survey.	Non-local traffic is above 50% for the highest hourly volume.	Yes

Findings

The Hamlet Community Association in Montgomery County petitioned for a determination of access restriction eligibility to address a perceived cut-through traffic problem. The results of a technical analysis confirm the following findings:

- The land use (Hamlet) is single family residential and serves internal (Hamlet local traffic) traffic.
- Existing traffic restrictions are present along the surrounding roadways adjacent to Hamlet but they do not cover Leland Street.
- Based on the capacity analysis results under the existing conditions, the MD 186 at MD 410 unsignalized intersection operates at an acceptable level of service and the MD 185 at MD 410 signalized intersection operate at an unacceptable level of service during the AM and PM peak hour.

Both the MD 186 at Leland Street and the MD 185 at Leland Street intersections operate at an acceptable during the AM and PM peak hour.

- The two-way traffic volumes on Leland Street satisfy the minimum requirements of 100 vehicles per hour during the morning peak hour only.
- A license tag survey documented 59% (84 vehicles) during the morning peak hour were non-local traffic on Leland Street.
- Based on the above findings, Leland Street is eligible for access restrictions during the morning peak period.

7. ACCESS RESTRICTION PLAN IMPACT ANALYSIS

An access restriction plan must balance the needs of both the neighborhood and the prevailing traffic conditions. An access restriction plan may not include traffic calming measures such as speed humps or small traffic circles, nor does it permit a complete roadway closure. The plan may include signs and/ or physical barriers that “establish turn or entry restrictions, one-way residential streets, or mandatory turns”.

The evaluation of access plans should include the consideration of impact of diverted traffic on other roadways such as residential and arterial streets, impact on access to public facilities and community resources such as schools, parks, libraries, religious institutions, or shopping centers, and lastly compatibility with area Master Plans.

Proposal

Based on the origin of cut-through traffic from the license plate survey and findings from the travel time analysis, Leland Street is being used as a cut-through to bypass signal delays from the westbound left turn from MD 410 to MD 185 southbound. To discourage the use of Leland Street as a cut-through, a no right turn restriction is recommended southbound on MD 186 at Leland Street during the AM peak period from 7:00 – 9:00 AM. While cut-through traffic may occur during the PM peak hour, and other times of day, the volume of traffic does not meet the eligibility requirements outline in Executive Regulation 17-94AM.

The restriction will require the installation of a regulatory sign to communicate the restriction and targeted police enforcement may be necessary to increase compliance.

A. Preliminary Restriction Plan Impacts

The proposed plans ultimately aim to provide access restrictions without further limiting through access for commuter and non-local cut-through traffic on roadways in the study area that serve local residences and businesses in the community. The proposed recommendations were weighted for advantages and disadvantages prior to traffic analysis and the following reasoning was applied:

B. Impact to Other Roadways

It is assumed that all traffic making the southbound right turn movement from MD 186 to Leland Street will utilize the arterial streets and access MD 185 southbound via the westbound left turn movement from MD



This additional diverted volume was added to the existing CLV volume for each affected intersection during the AM peak hour when the restriction is in place and the results are summarized below in Table 7. The results indicate that the additional diverted traffic volumes would not cause deterioration of LOS at any of the study intersections during the AM peak hour. CLV worksheets with the diverted traffic volumes can be found in Appendix D.

TABLE 7: FUTURE INTERSECTION CAPACITY ANALYSIS - AM PEAK

Intersection	Critical Lane Volume	Volume-to-Capacity Ratio	Level of Service
MD 410 at MD 186	643	0.40	A
MD 410 at MD 185	1469	0.92	E
Leland St at MD 186	617	0.39	A
Leland St at MD 185	797	0.50	A
Bradley Ln at MD 186	718	0.45	A
Bradley Ln at MD 185	1346	0.84	D

C. Impact to Public and Community Facilities

The proposed access and turn restrictions are only limited to the morning peak hours, 7:00 – 9:00 AM to discourage through commuter traffic along westbound Leland Street. The evening peak hour, when most local residents are returning home from work or errand will be unaffected. Additionally, the existing transit route along Leland Street would not be impacted by the turn restriction.

8. SUMMARY AND RECOMMENDATION

The Hamlet community in Montgomery County petitioned for a determination of access restriction eligibility to address a perceived cut-through traffic problem. The results of a technical analysis confirm the following findings:

- Westbound AM peak-hour traffic exceeds 100 vehicles on Leland Street, while PM peak-hour westbound traffic and *both* AM/PM eastbound traffic did not; accordingly, only AM westbound cut-through conditions were evaluated further.
- A comparison of field-measured travel times in the study area during morning peak hours indicate a about two minutes in travel time for non-local traffic by using Leland Street in lieu of remaining on MD 410.
- A license plate survey of westbound traffic documented non-local traffic volumes on Leland Street, which were found to be more than 50% of morning peak hour traffic.
- Based on the overall AM peak hour volumes in the westbound direction, as the percentage of non-local traffic, Leland Street meets the County's requirements for access restrictions per Executive Regulation 17-94.
- The majority of the traffic entering Leland Street came from southbound MD 186.
- The recommended access restriction is:

Installation of a regulatory sign to restrict southbound right turns from MD 186 to Leland Street from 7:00 – 9:00 AM.

With plaque to include "except buses" to account for Ride-On bus and service and school buses

- Based on CLV analysis of study area intersections that would see modified traffic patterns, this regulation was not found to significantly impact adjacent roadways or intersections.



APPENDIX A – TRAFFIC COUNTS



Maryland Department of Transportation
 State Highway Administration
 Data Services Division
 Turning Movement Summary Report

Station ID: S2001150055 County: Montgomery Comments:
 Date: 2/24/2021 12:00:00 AM Town: none
 Location: MD 186 at MD 410 Weather: Clear
 Interval: 60 Min

PEAK	AM PERIOD	Start	End	Volume	LOS	V/C	PM PERIOD	Start	End	Volume	LOS	V/C
Hours	6:00AM-12:00PM	08:00	09:00	1227	A	0.3	12:00PM-19:00PM	16:00	17:00	1767	A	0.53

MD 186
MD 410
MD 410

From North
From South
From East
From West

Begin Hour	From North					From South					From East					From West					GrandTotal
	U.Turn	Left	Through	Right	TOTAL	U.Turn	Left	Through	Right	TOTAL	U.Turn	Left	Through	Right	TOTAL	U.Turn	Left	Through	Right	TOTAL	
00:00	0	0	0	0	0	0	2	0	3	5	0	1	15	0	16	0	0	40	4	44	65
01:00	0	0	0	0	0	0	0	0	2	2	0	1	9	0	10	0	0	19	0	19	31
02:00	0	0	0	0	0	0	0	0	1	1	0	0	5	0	5	0	0	3	1	4	10
03:00	0	0	0	0	0	0	0	0	0	0	0	0	18	0	18	0	0	10	0	10	28
04:00	0	0	0	0	0	0	1	0	1	2	0	1	35	0	36	0	0	10	2	12	50
05:00	0	0	0	0	0	0	5	0	3	8	0	5	132	0	137	0	0	43	4	47	192
06:00	0	0	0	0	0	0	10	0	6	16	0	58	357	0	415	0	0	97	14	111	542
07:00	0	0	0	0	0	0	20	0	28	48	0	192	442	0	634	0	0	235	50	285	967
08:00	0	0	0	0	0	0	20	0	51	71	0	212	545	0	757	0	0	337	62	399	1227
09:00	0	0	0	0	0	0	45	0	56	101	0	104	396	0	500	0	0	370	64	434	1035
10:00	0	0	0	0	0	0	51	0	60	111	0	80	405	0	485	0	0	373	52	425	1021
11:00	0	0	0	0	0	0	51	0	69	120	0	67	416	0	483	1	0	410	53	464	1067
12:00	0	0	0	0	0	0	53	0	96	149	0	62	416	0	478	0	0	471	44	515	1142
13:00	0	0	0	0	0	0	57	0	87	144	0	65	382	0	447	0	0	465	57	522	1113
14:00	0	0	0	0	0	0	51	0	117	168	0	57	405	0	462	0	0	565	55	620	1250
15:00	0	0	0	0	0	0	59	0	248	307	0	62	445	0	507	0	0	766	50	816	1630
16:00	0	0	0	0	0	0	54	0	328	382	0	70	395	0	465	0	0	878	42	920	1767
17:00	0	0	0	0	0	0	57	0	282	339	0	57	421	0	478	0	0	802	59	861	1678
18:00	0	0	0	0	0	0	41	0	93	134	0	53	316	0	369	0	0	566	41	607	1110
19:00	0	0	0	0	0	0	18	0	61	79	0	18	213	0	231	0	0	349	27	376	686
20:00	0	0	0	0	0	0	11	0	29	40	0	13	182	0	195	0	0	267	20	287	522
21:00	0	0	0	0	0	0	5	0	18	23	0	11	112	0	123	0	0	171	10	181	327
22:00	0	0	0	0	0	0	3	0	11	14	0	3	69	0	72	0	0	111	7	118	204
23:00	0	0	0	0	0	0	2	0	9	11	0	2	32	0	34	0	0	92	0	92	137
TOTAL	0	0	0	0	0	0	616	0	1659	2275	0	1194	6163	0	7357	1	0	7450	718	8169	17801
AMPEAK	0	0	0	0	0	0	20	0	51	71	0	212	545	0	757	0	0	337	62	399	1227
PMPEAK	0	0	0	0	0	0	54	0	328	382	0	70	395	0	465	0	0	878	42	920	1767
DAYPEAK	0	0	0	0	0	0	54	0	328	382	0	70	395	0	465	0	0	878	42	920	1767



Maryland Department of Transportation
 State Highway Administration
 Data Services Division
 Turning Movement Summary Report

Station ID: S2001150055

County: Montgomery

Comments:

Date: 2/24/2021 12:00:00 AM

Town: none

Location: MD 186 at MD 410

Weather: Clear

Interval: 60 Min

PEAK	AM PERIOD	Start	End	Volume	LOS	V/C	PM PERIOD	Start	End	Volume	LOS	V/C
Hours	6:00AM-12:00PM	08:00	09:00	1227	A	0.3	12:00PM-19:00PM	16:00	17:00	1767	A	0.53



Turning Movement Summary

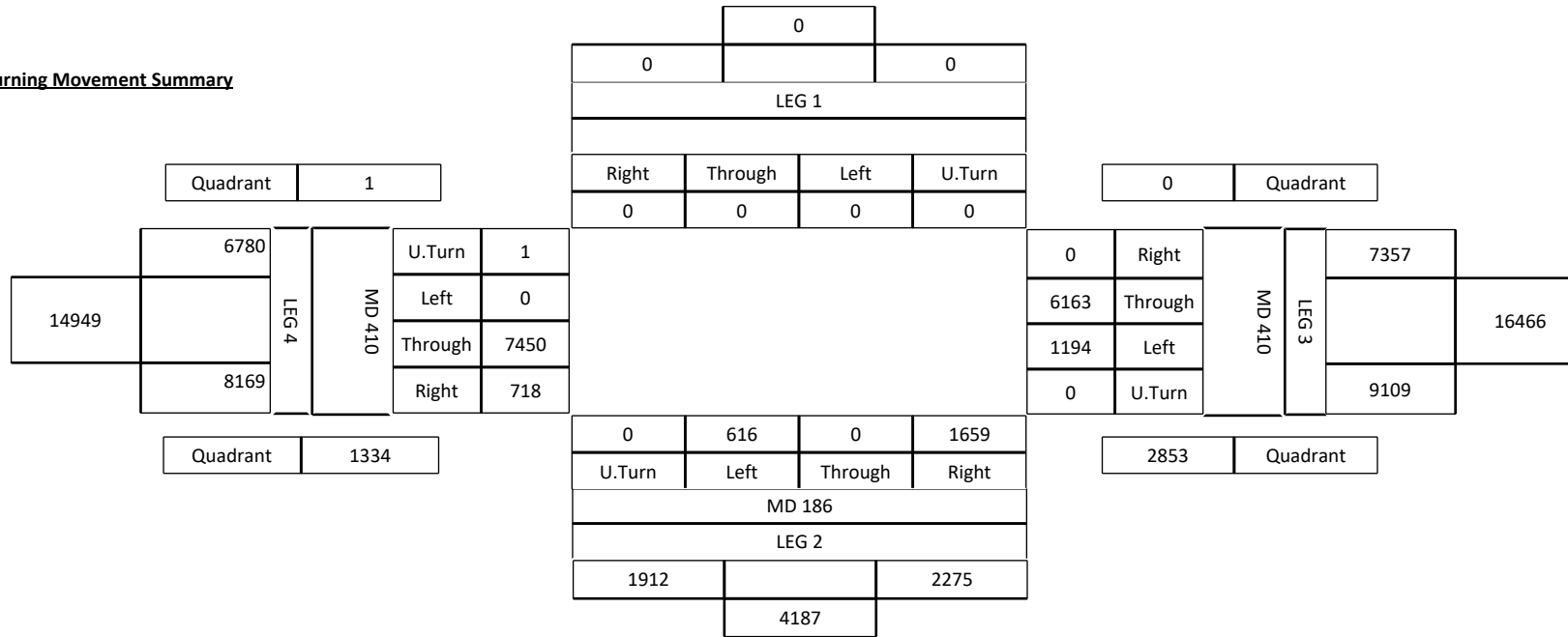



Maryland Department of Transportation
 State Highway Administration
 Data Services Division
 Turning Movement Summary Report

Station ID: S2001150055

County: Montgomery

Comments:

Date: 2/24/2021 12:00:00 AM

Town: none

Location: MD 186 at MD 410

Weather: Clear

Interval: 60 Min

PEAK	AM PERIOD	Start	End	Volume	LOS	V/C	PM PERIOD	Start	End	Volume	LOS	V/C
Hours	6:00AM-12:00PM	08:00	09:00	1227	A	0.3	12:00PM-19:00PM	16:00	17:00	1767	A	0.53



AM Peak Hour

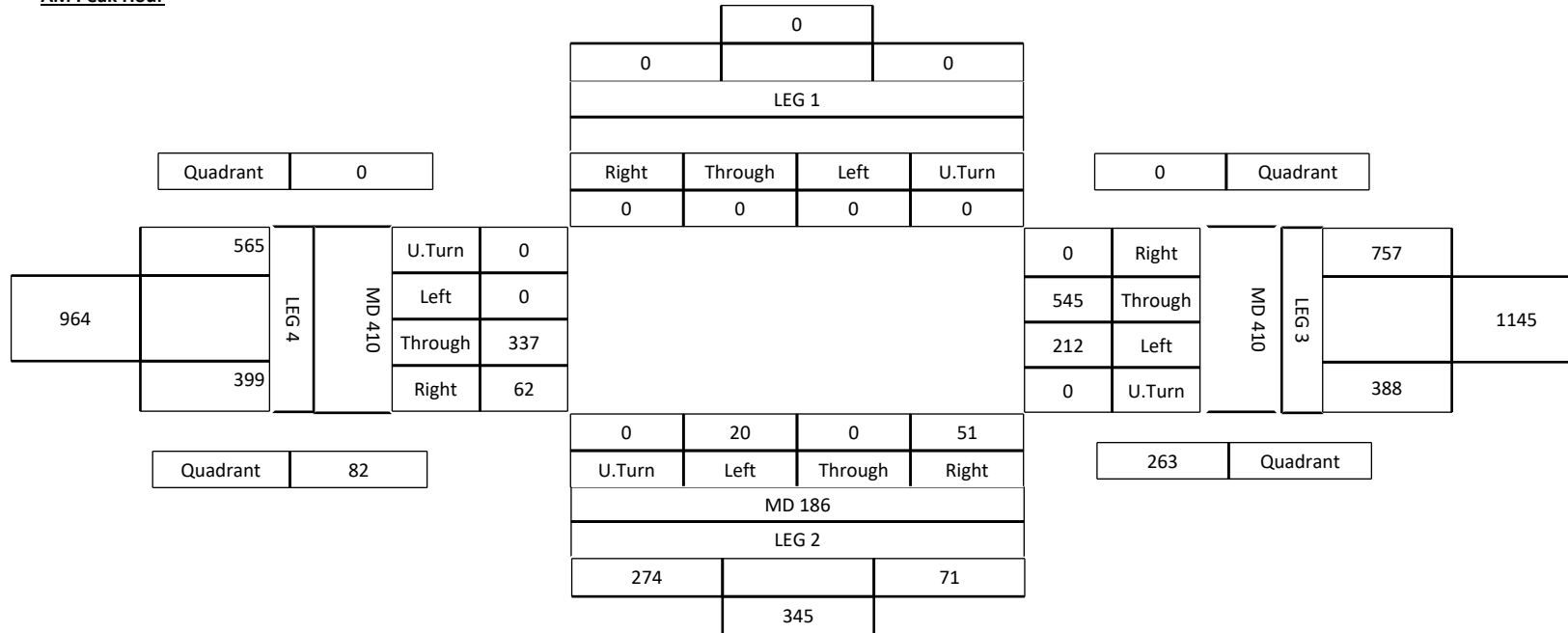



Maryland Department of Transportation
 State Highway Administration
 Data Services Division
 Turning Movement Summary Report

Station ID: S2001150055

County: Montgomery

Comments:

Date: 2/24/2021 12:00:00 AM

Town: none

Location: MD 186 at MD 410

Weather: Clear

Interval: 60 Min

PEAK	AM PERIOD	Start	End	Volume	LOS	V/C	PM PERIOD	Start	End	Volume	LOS	V/C
Hours	6:00AM-12:00PM	08:00	09:00	1227	A	0.3	12:00PM-19:00PM	16:00	17:00	1767	A	0.53

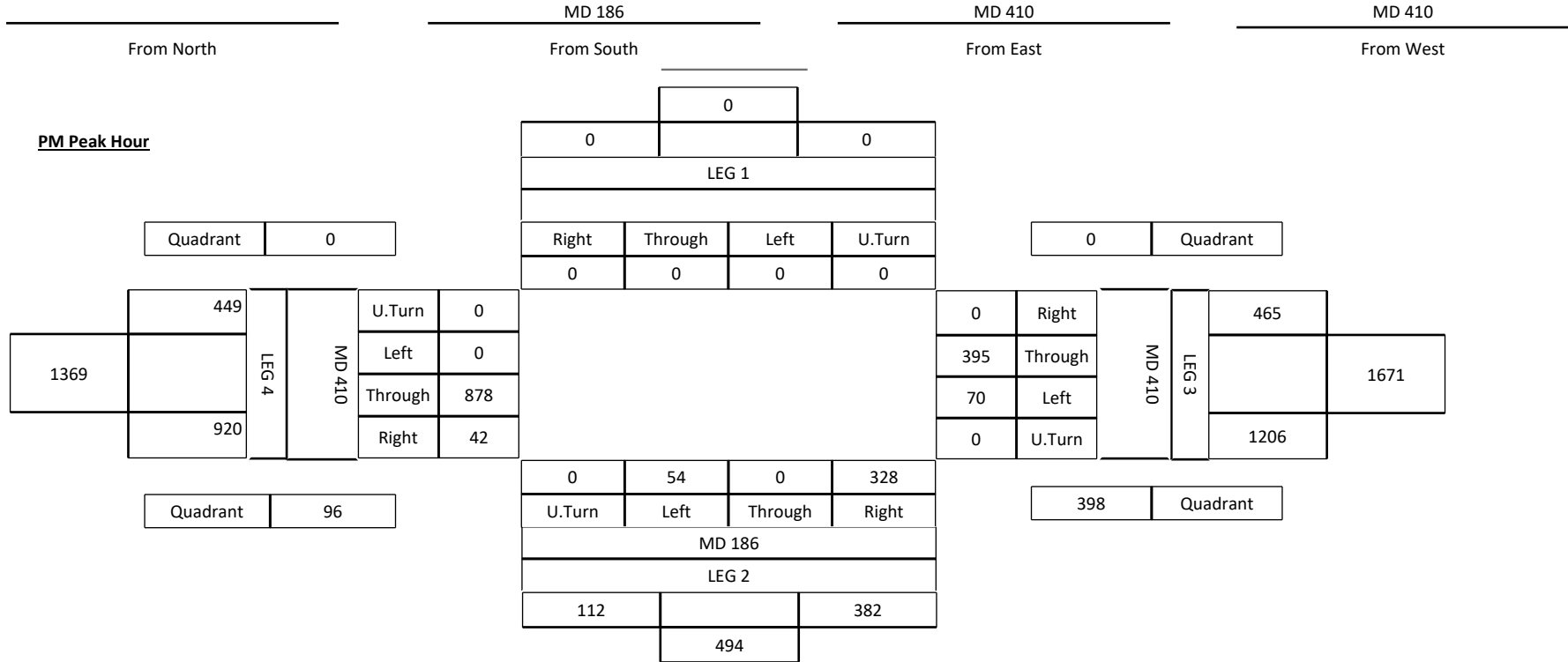



Maryland Department of Transportation
 State Highway Administration
 Data Services Division
 Turning Movement Summary Report

Station ID: S2001150055
 Date: 2/24/2021 12:00:00 AM
 Location: MD 186 at MD 410
 Interval: 60 Min

County: Montgomery
 Town: none
 Weather: Clear

Comments:

PEAK	AM PERIOD	Start	End	Volume	LOS	V/C	PM PERIOD	Start	End	Volume	LOS	V/C
Hours	6:00AM-12:00PM	08:00	09:00	1227	A	0.3	12:00PM-19:00PM	16:00	17:00	1767	A	0.53

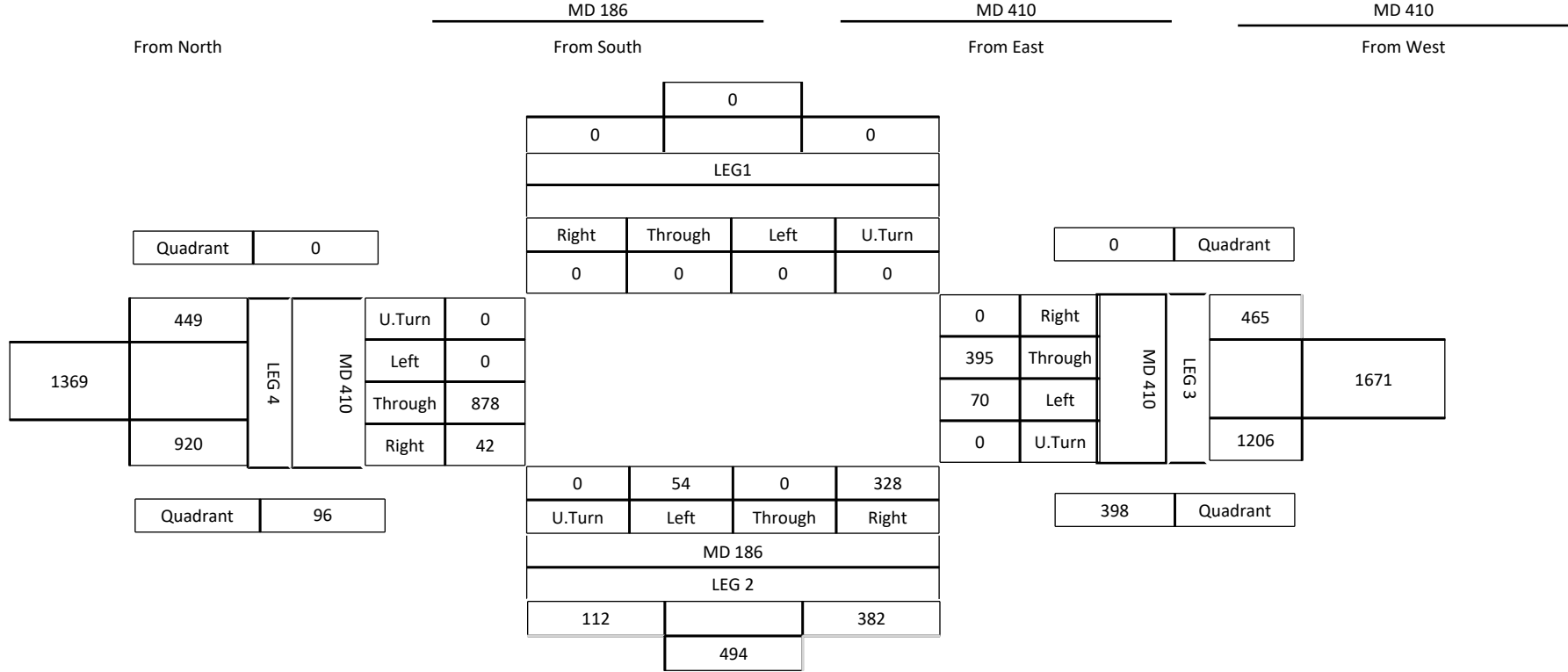

Traffic Counts Report (15 Min Interval)

Intersection: Connecticut Ave at East West Hwy

Count Date: Wednesday, 5/15/2019

Count Source: SABRA ASSOICATES



AM Start Time	AM Peak Hour	AM Peak CLV	AM Peak Delay	PM End Time	PM Peak Hour	PM Peak CLV
06:30	07:45 to 08:45	1463		19:00	16:45 to 17:45	1479

PM Peak Delay

	NORTH BOUND				SOUTH BOUND				EAST BOUND				WEST BOUND				OTHER BOUND			
	CONNECTICUT AVE (MD 185)				CONNECTICUT AVE (MD 185)				EAST-WEST HWY (MD 410)				EAST-WEST HWY (MD 410)							
START TIME	L	T	R	O	L	T	R	O	L	T	R	O	L	T	R	O	L	T	R	O
06:30	10	144	4	0	16	429	90	0	20	23	11	0	40	126	2	0	0	0	0	0
06:45	12	175	3	0	40	477	128	0	30	21	13	0	33	115	3	0	0	0	0	0
07:00	20	207	3	0	22	422	131	0	44	43	16	0	41	112	12	0	0	0	0	0
07:15	28	260	23	0	21	407	132	0	57	44	29	0	30	150	9	0	0	0	0	0
07:30	43	266	19	0	18	439	100	0	69	57	35	0	31	169	10	0	0	0	0	0
07:45	37	329	18	0	19	448	90	0	78	73	33	0	39	114	15	0	0	0	0	0
08:00	42	286	26	0	20	410	120	0	82	92	18	0	37	134	17	0	0	0	0	0
08:15	42	330	47	0	24	386	139	0	80	81	8	0	23	161	19	0	0	0	0	0
08:30	41	358	22	0	21	367	155	0	73	67	28	0	33	169	9	0	0	0	0	0
08:45	46	338	28	0	23	393	175	0	61	64	20	0	14	142	13	0	0	0	0	0
09:00	42	293	29	0	19	361	152	0	71	61	26	0	23	171	10	0	0	0	0	0
09:15	39	260	33	0	19	401	144	0	53	64	20	0	23	149	13	0	0	0	0	0
11:00	24	225	55	0	64	296	61	0	68	83	11	0	32	107	20	0	0	0	0	0
11:15	20	213	70	0	69	301	87	0	73	82	9	0	39	82	20	0	0	0	0	0
11:30	21	219	56	0	50	291	79	0	78	86	5	0	37	73	17	0	0	0	0	0
11:45	22	271	43	0	39	310	95	0	71	74	10	0	34	98	20	0	0	0	0	0
12:00	22	298	32	0	38	282	80	0	87	68	10	0	44	77	14	0	0	0	0	0
12:15	16	298	30	0	30	287	71	0	101	81	10	0	29	70	31	0	0	0	0	0
12:30	13	294	34	0	45	257	105	0	97	70	16	0	34	68	20	0	0	0	0	0
12:45	23	282	35	0	35	273	71	0	91	81	8	0	34	87	17	0	0	0	0	0
16:00	20	360	47	0	44	264	70	0	183	176	18	0	28	89	33	0	0	0	0	0
16:15	29	327	32	0	47	272	60	0	153	213	17	0	34	73	44	0	0	0	0	0
16:30	12	362	45	0	39	298	66	0	185	190	21	0	34	86	22	0	0	0	0	0
16:45	14	379	39	0	35	300	72	0	182	212	17	0	29	100	37	0	0	0	0	0
17:00	13	390	38	0	51	292	78	0	181	218	31	0	31	77	32	0	0	0	0	0
17:15	18	408	43	0	50	302	77	0	182	205	17	0	26	86	24	0	0	0	0	0
17:30	19	407	35	0	45	306	80	0	186	169	25	0	37	101	19	0	0	0	0	0
17:45	22	418	37	0	44	271	63	0	188	195	19	0	34	93	33	0	0	0	0	0
18:00	15	370	29	0	40	196	54	0	192	200	18	0	34	77	41	0	0	0	0	0
18:15	22	390	42	0	39	235	59	0	181	211	18	0	28	111	39	0	0	0	0	0
18:30	23	368	25	0	46	296	64	0	174	200	20	0	23	81	37	0	0	0	0	0
18:45	24	346	52	0	46	213	37	0	151	156	19	0	29	80	16	0	0	0	0	0
Total	794	9871	1074	0	1158	1048 2	2985	0	3522	3660	576	0	1017	3428	668	0	0	0	0	0

Traffic Counts Report (30 Min Interval)

Intersection: Connecticut Ave at East West Hwy

Count Date: Wednesday, 5/15/2019

Count Source: SABRA ASSOICATES



AM Start Time	PM End Time
06:30	19:00

START TIME	NORTH BOUND				SOUTH BOUND				EAST BOUND				WEST BOUND				OTHER BOUND			
	CONNECTICUT AVE (MD 185)				CONNECTICUT AVE (MD 185)				EAST-WEST HWY (MD 410)				EAST-WEST HWY (MD 410)							
	L	T	R	O	L	T	R	O	L	T	R	O	L	T	R	O	L	T	R	O
06:30	22	319	7	0	56	906	218	0	50	44	24	0	73	241	5	0	0	0	0	0
07:00	48	467	26	0	43	829	263	0	101	87	45	0	71	262	21	0	0	0	0	0
07:30	80	595	37	0	37	887	190	0	147	130	68	0	70	283	25	0	0	0	0	0
08:00	84	616	73	0	44	796	259	0	162	173	26	0	60	295	36	0	0	0	0	0
08:30	87	696	50	0	44	760	330	0	134	131	48	0	47	311	22	0	0	0	0	0
09:00	81	553	62	0	38	762	296	0	124	125	46	0	46	320	23	0	0	0	0	0
16:00	49	687	79	0	91	536	130	0	336	389	35	0	62	162	77	0	0	0	0	0
16:30	26	741	84	0	74	598	138	0	367	402	38	0	63	186	59	0	0	0	0	0
17:00	31	798	81	0	101	594	155	0	363	423	48	0	57	163	56	0	0	0	0	0
17:30	41	825	72	0	89	577	143	0	374	364	44	0	71	194	52	0	0	0	0	0
18:00	37	760	71	0	79	431	113	0	373	411	36	0	62	188	80	0	0	0	0	0
18:30	47	714	77	0	92	509	101	0	325	356	39	0	52	161	53	0	0	0	0	0
Total	633	7771	719	0	788	8185	2336	0	2856	3035	497	0	734	2766	509	0	0	0	0	0

Traffic Counts Report (60 Min Interval)

Intersection: Connecticut Ave at East West Hwy

Count Date: Wednesday, 5/15/2019

Count Source: SABRA ASSOICATES



AM Start Time	PM End Time
06:30	19:00

START TIME	NORTH BOUND				SOUTH BOUND				EAST BOUND				WEST BOUND				OTHER BOUND			
	CONNECTICUT AVE (MD 185)				CONNECTICUT AVE (MD 185)				EAST-WEST HWY (MD 410)				EAST-WEST HWY (MD 410)							
	L	T	R	O	L	T	R	O	L	T	R	O	L	T	R	O	L	T	R	O
06:30	70	786	33	0	99	1735	481	0	151	131	69	0	144	503	26	0	0	0	0	0
07:30	164	1211	110	0	81	1683	449	0	309	303	94	0	130	578	61	0	0	0	0	0
08:30	168	1249	112	0	82	1522	626	0	258	256	94	0	93	631	45	0	0	0	0	0
16:00	75	1428	163	0	165	1134	268	0	703	791	73	0	125	348	136	0	0	0	0	0
17:00	72	1623	153	0	190	1171	298	0	737	787	92	0	128	357	108	0	0	0	0	0
18:00	84	1474	148	0	171	940	214	0	698	767	75	0	114	349	133	0	0	0	0	0
Total	633	7771	719	0	788	8185	2336	0	2856	3035	497	0	734	2766	509	0	0	0	0	0

Start Date: 3/30/2022

Start Time: 7:00:00 AM

Site Code: 00000000

Comment 1: Default Comments

Comment 2: Change These in The Preferences Window

Comment 3: Select File/Preference in the Main Scree

Comment 4: Then Click the Comments Tab

Start Time	MD 186 From North						LELAND ST From East						MD 186 From South						LELAND ST From West						CURTIS ST From Northwest						
	Left	Thru	Right	Hard Right	U TURNS	Total	Left	Thru	Bear Right	Right	U TURNS	Total	Left	Bear Left	Thru	Right	U TURNS	Total	Hard Left	Left	Thru	Right	U TURNS	Total	Hard Left	Bear Left	Bear Right	Hard Right	U TURNS	Total	
7:00:00 AM	4	58	1	0	0	63	0	5	0	0	5	1	0	13	0	0	14	0	0	1	1	0	2	0	1	0	1	3	0	0	4
7:15:00 AM	1	80	2	1	0	84	4	15	0	1	20	5	0	14	0	0	19	0	1	0	0	0	1	0	2	2	2	2	0	6	
7:30:00 AM	3	123	20	0	0	146	0	11	0	2	13	4	0	9	0	0	13	0	0	4	2	0	6	0	2	5	0	0	7		
7:45:00 AM	12	129	10	1	0	152	0	4	0	1	5	2	2	11	2	0	17	1	2	3	4	0	10	1	2	5	1	0	9		
8:00:00 AM	12	122	11	0	0	145	2	9	0	2	13	5	0	20	2	0	27	0	0	0	0	0	0	0	3	5	0	0	8		
8:15:00 AM	21	130	15	0	1	167	0	10	0	2	12	5	0	21	2	0	28	0	0	2	2	0	4	0	2	7	3	0	12		
8:30:00 AM	7	124	17	0	0	148	3	8	0	0	11	8	0	13	0	0	21	0	0	1	3	0	4	0	3	6	2	0	11		
8:45:00 AM	9	111	10	0	0	130	3	4	1	1	9	10	0	19	1	0	30	0	2	3	5	0	10	0	1	8	1	0	10		
9:00:00 AM	0	0	0	0	0	0	0	0	0	0	0	0	0	0	0	0	0	0	0	0	0	0	0	0	0	0	0	0	0	0	
9:15:00 AM	0	0	0	0	0	0	0	0	0	0	0	0	0	0	0	0	0	0	0	0	0	0	0	0	0	0	0	0	0	0	
9:30:00 AM	0	0	0	0	0	0	0	0	0	0	0	0	0	0	0	0	0	0	0	0	0	0	0	0	0	0	0	0	0	0	
9:45:00 AM	0	0	0	0	0	0	0	0	0	0	0	0	0	0	0	0	0	0	0	0	0	0	0	0	0	0	0	0	0	0	
10:00:00 AM	0	0	0	0	0	0	0	0	0	0	0	0	0	0	0	0	0	0	0	0	0	0	0	0	0	0	0	0	0	0	
10:15:00 AM	0	0	0	0	0	0	0	0	0	0	0	0	0	0	0	0	0	0	0	0	0	0	0	0	0	0	0	0	0	0	
10:30:00 AM	0	0	0	0	0	0	0	0	0	0	0	0	0	0	0	0	0	0	0	0	0	0	0	0	0	0	0	0	0	0	
10:45:00 AM	0	0	0	0	0	0	0	0	0	0	0	0	0	0	0	0	0	0	0	0	0	0	0	0	0	0	0	0	0	0	
11:00:00 AM	0	0	0	0	0	0	0	0	0	0	0	0	0	0	0	0	0	0	0	0	0	0	0	0	0	0	0	0	0	0	
11:15:00 AM	0	0	0	0	0	0	0	0	0	0	0	0	0	0	0	0	0	0	0	0	0	0	0	0	0	0	0	0	0	0	
11:30:00 AM	0	0	0	0	0	0	0	0	0	0	0	0	0	0	0	0	0	0	0	0	0	0	0	0	0	0	0	0	0	0	
11:45:00 AM	0	0	0	0	0	0	0	0	0	0	0	0	0	0	0	0	0	0	0	0	0	0	0	0	0	0	0	0	0	0	
12:00:00 PM	0	0	0	0	0	0	0	0	0	0	0	0	0	0	0	0	0	0	0	0	0	0	0	0	0	0	0	0	0	0	
12:15:00 PM	0	0	0	0	0	0	0	0	0	0	0	0	0	0	0	0	0	0	0	0	0	0	0	0	0	0	0	0	0	0	
12:30:00 PM	0	0	0	0	0	0	0	0	0	0	0	0	0	0	0	0	0	0	0	0	0	0	0	0	0	0	0	0	0	0	
12:45:00 PM	0	0	0	0	0	0	0	0	0	0	0	0	0	0	0	0	0	0	0	0	0	0	0	0	0	0	0	0	0	0	
1:00:00 PM	0	0	0	0	0	0	0	0	0	0	0	0	0	0	0	0	0	0	0	0	0	0	0	0	0	0	0	0	0	0	
1:15:00 PM	0	0	0	0	0	0	0	0	0	0	0	0	0	0	0	0	0	0	0	0	0	0	0	0	0	0	0	0	0	0	
1:30:00 PM	0	0	0	0	0	0	0	0	0	0	0	0	0	0	0	0	0	0	0	0	0	0	0	0	0	0	0	0	0	0	
1:45:00 PM	0	0	0	0	0	0	0	0	0	0	0	0	0	0	0	0	0	0	0	0	0	0	0	0	0	0	0	0	0	0	
2:00:00 PM	0	0	0	0	0	0	0	0	0	0	0	0	0	0	0	0	0	0	0	0	0	0	0	0	0	0	0	0	0	0	
2:15:00 PM	0	0	0	0	0	0	0	0	0	0	0	0	0	0	0	0	0	0	0	0	0	0	0	0	0	0	0	0	0	0	
2:30:00 PM	0	0	0	0	0	0	0	0	0	0	0	0	0	0	0	0	0	0	0	0	0	0	0	0	0	0	0	0	0	0	
2:45:00 PM	0	0	0	0	0	0	0	0	0	0	0	0	0	0	0	0	0	0	0	0	0	0	0	0	0	0	0	0	0	0	
3:00:00 PM	0	0	0	0	0	0	0	0	0	0	0	0	0	0	0	0	0	0	0	0	0	0	0	0	0	0	0	0	0	0	
3:15:00 PM	0	0	0	0	0	0	0	0	0	0	0	0	0	0	0	0	0	0	0	0	0	0	0	0	0	0	0	0	0	0	
3:30:00 PM	0	0	0	0	0	0	0	0	0	0	0	0	0	0	0	0	0	0	0	0	0	0	0	0	0	0	0	0	0	0	
3:45:00 PM	0	0	0	0	0	0	0	0	0	0	0	0	0	0	0	0	0	0	0	0	0	0	0	0	0	0	0	0	0	0	
4:00:00 PM	2	24	1	0	0	27	3	5	1	7	16	8	1	81	2	0	92	0	0	3	5	0	8	0	0	5	0	0	5		
4:15:00 PM	3	18	0	0	0	21	1	3	1	10	15	5	1	125	0	0	131	0	4	2	2	0	8	0	2	9	0	0	11		
4:30:00 PM	7	26	0	1	0	34	1	6	3	8	18	3	3	127	8	0	141	0	0	3	6	0	9	0	3	4	0	0	7		
4:45:00 PM	4	32	2	0	0	38	0	8	0	15	23	4	2	134	4	0	144	0	1	2	3	0	6	0	2	9	2	0	13		
5:00:00 PM	8	29	1	0	0	38	0	10	0	16	26	6	2	115	1	0	124	0	1	1	2	0	4	1	1	6	1	0	9		
5:15:00 PM	5	30	2	0	0	37	1	4	0	5	10	2	0	100	1	0	103	1	0	4	4	0	9	0	4	11	0	0	15		
5:30:00 PM	5	30	2	1	0	38	0	4	1	11	16	6	1	120	2	0	129	0	1	2	2	0	5	0	2	6	0	0	8		
5:45:00 PM	7	33	3	0	0	43	1	3	0	8	12	6	0	133	1	0	140	0	5	2	7	0	14	0	2	9	0	0	11		
6:00:00 PM	5	37	2	1	0	45	0	5	2	9	16	3	1	92	5	0	101	0	0	5	3	0	8	2	2	7	1	0	12		
6:15:00 PM	4	25	0	0	0	29	3	4	0	2	9	3	1	61	2	0	67	0	1	2	2	0	5	0	1	5	1	0	7		
6:30:00 PM	7	24	3	0	0	34	0	1	0	2	3	2	0	53	2	0	57	0	2	2	1	0	5	1	2	4	1	0	8		
6:45:00 PM	4	18	1	0	0	23	0	3	0	0	3	2	0	36	0	0	38	0	2	4	3	0	9	0	2	8	0	0	10		

Site Code: 00000000

Comment 1: Default Comments

Comment 2: Change These in The Preferences Window

Comment 3: Select File/Preference in the Main Scree

Comment 4: Then Click the Comments Tab

Start Time	MD 185 From North					LELAND ST From East					MD 185 From South					LELAND ST From West				
	Left	Thru	Right	Total	Peds	Left	Thru	Right	Total	Peds	Left	Thru	Right	Total	Peds	Left	Thru	Right	Total	Peds
7:00:00 AM	2	416	0	418	0	4	0	1	5	0	1	160	0	161	0	0	1	3	4	0
7:15:00 AM	1	470	1	472	0	4	0	14	18	0	0	236	0	236	0	1	0	2	3	0
7:30:00 AM	1	500	0	501	0	11	1	8	20	0	0	245	1	246	0	0	0	0	0	0
7:45:00 AM	1	537	2	540	0	11	1	6	18	0	0	281	1	282	0	0	0	1	1	0
8:00:00 AM	0	520	0	520	0	9	0	9	18	0	1	294	0	295	0	0	0	1	1	0
8:15:00 AM	2	509	0	511	1	11	2	6	19	0	0	313	3	316	0	0	0	3	3	0
8:30:00 AM	1	484	0	485	0	17	1	11	29	0	0	301	2	303	0	1	0	4	5	0
8:45:00 AM	1	454	2	457	0	10	1	10	21	0	1	273	4	278	0	0	0	2	2	0
9:00:00 AM	0	0	0	0	0	0	0	0	0	0	0	0	0	0	0	0	0	0	0	0
9:15:00 AM	0	0	0	0	0	0	0	0	0	0	0	0	0	0	0	0	0	0	0	0
9:30:00 AM	0	0	0	0	0	0	0	0	0	0	0	0	0	0	0	0	0	0	0	0
9:45:00 AM	0	0	0	0	0	0	0	0	0	0	0	0	0	0	0	0	0	0	0	0
10:00:00 AM	0	0	0	0	0	0	0	0	0	0	0	0	0	0	0	0	0	0	0	0
10:15:00 AM	0	0	0	0	0	0	0	0	0	0	0	0	0	0	0	0	0	0	0	0
10:30:00 AM	0	0	0	0	0	0	0	0	0	0	0	0	0	0	0	0	0	0	0	0
10:45:00 AM	0	0	0	0	0	0	0	0	0	0	0	0	0	0	0	0	0	0	0	0
11:00:00 AM	0	0	0	0	0	0	0	0	0	0	0	0	0	0	0	0	0	0	0	0
11:15:00 AM	0	0	0	0	0	0	0	0	0	0	0	0	0	0	0	0	0	0	0	0
11:30:00 AM	0	0	0	0	0	0	0	0	0	0	0	0	0	0	0	0	0	0	0	0
11:45:00 AM	0	0	0	0	0	0	0	0	0	0	0	0	0	0	0	0	0	0	0	0
12:00:00 PM	0	0	0	0	0	0	0	0	0	0	0	0	0	0	0	0	0	0	0	0
12:15:00 PM	0	0	0	0	0	0	0	0	0	0	0	0	0	0	0	0	0	0	0	0
12:30:00 PM	0	0	0	0	0	0	0	0	0	0	0	0	0	0	0	0	0	0	0	0
12:45:00 PM	0	0	0	0	0	0	0	0	0	0	0	0	0	0	0	0	0	0	0	0
1:00:00 PM	0	0	0	0	0	0	0	0	0	0	0	0	0	0	0	0	0	0	0	0
1:15:00 PM	0	0	0	0	0	0	0	0	0	0	0	0	0	0	0	0	0	0	0	0
1:30:00 PM	0	0	0	0	0	0	0	0	0	0	0	0	0	0	0	0	0	0	0	0
1:45:00 PM	0	0	0	0	0	0	0	0	0	0	0	0	0	0	0	0	0	0	0	0
2:00:00 PM	0	0	0	0	0	0	0	0	0	0	0	0	0	0	0	0	0	0	0	0
2:15:00 PM	0	0	0	0	0	0	0	0	0	0	0	0	0	0	0	0	0	0	0	0
2:30:00 PM	0	0	0	0	0	0	0	0	0	0	0	0	0	0	0	0	0	0	0	0
2:45:00 PM	0	0	0	0	0	0	0	0	0	0	0	0	0	0	0	0	0	0	0	0
3:00:00 PM	0	0	0	0	0	0	0	0	0	0	0	0	0	0	0	0	0	0	0	0
3:15:00 PM	0	0	0	0	0	0	0	0	0	0	0	0	0	0	0	0	0	0	0	0
3:30:00 PM	0	0	0	0	0	0	0	0	0	0	0	0	0	0	0	0	0	0	0	0
3:45:00 PM	0	0	0	0	0	0	0	0	0	0	0	0	0	0	0	0	0	0	0	0
4:00:00 PM	2	271	3	276	0	0	0	2	2	0	1	458	8	467	0	0	0	0	0	0
4:15:00 PM	2	301	2	305	0	0	0	3	3	0	0	430	10	440	0	0	0	1	1	0
4:30:00 PM	3	333	8	344	1	0	1	2	3	0	1	448	6	455	0	0	1	2	3	0
4:45:00 PM	1	323	4	328	0	0	0	0	0	0	2	465	4	471	0	0	0	0	0	0
5:00:00 PM	1	317	4	322	0	1	0	4	5	0	0	484	6	490	0	1	1	2	4	0
5:15:00 PM	1	336	6	343	0	0	0	3	3	0	3	452	4	459	0	0	0	1	1	0
5:30:00 PM	1	319	3	323	0	0	0	2	2	0	0	442	8	450	0	0	0	3	3	0
5:45:00 PM	0	366	4	370	0	1	0	1	2	0	1	471	11	483	0	0	1	3	4	0
6:00:00 PM	3	290	2	295	0	1	2	3	6	0	5	464	3	472	0	1	1	4	6	0
6:15:00 PM	1	295	4	300	0	0	1	3	4	0	4	492	7	503	0	1	0	0	1	0
6:30:00 PM	1	313	2	316	0	0	0	7	7	0	2	397	3	402	0	0	0	1	1	0
6:45:00 PM	1	284	4	289	0	2	0	2	4	0	2	370	3	375	0	0	0	1	1	0



Maryland Department of Transportation
State Highway Administration
Data Services Division

Turning Movement Summary Report

Station ID: S2002150006

County: Montgomery

Comments: LOS AM:A PM:A

Date: 1/22/2008 6:00:00 AM

Town: none

Location: MD 186 at E BRADLEY LA

Weather:

Interval: 60 Min

PEAK	AM PERIOD	Start	End	Volume	LOS	V/C	PM PERIOD	Start	End	Volume	LOS	V/C
Hours	6:00AM-12:00PM	08:00	09:00	862	N/A	N/A	12:00PM-19:00PM	17:00	18:00	794	N/A	N/A

MD 186

MD 186

EAST BRADLEY LANE

EAST BRADLEY LANE

From North

From South

From East

From West

Begin Hour	From North					From South					From East					From West					GrandTotal
	U.Turn	Left	Through	Right	TOTAL	U.Turn	Left	Through	Right	TOTAL	U.Turn	Left	Through	Right	TOTAL	U.Turn	Left	Through	Right	TOTAL	
06:00	0	0	93	24	117	0	12	20	1	33	0	2	2	0	4	0	4	0	6	10	164
07:00	0	0	421	91	512	0	42	77	7	126	0	12	1	4	17	0	9	1	30	40	695
08:00	0	1	469	142	612	0	47	139	2	188	0	10	3	2	15	0	18	2	27	47	862
09:00	0	2	304	80	386	0	43	133	2	178	0	6	2	4	12	0	9	0	21	30	606
10:00	0	3	143	55	201	0	29	132	2	163	0	5	1	3	9	0	27	0	21	48	421
11:00	0	1	124	53	178	0	31	108	4	143	0	1	1	3	5	0	30	0	32	62	388
12:00	0	3	153	48	204	0	42	165	1	208	0	4	0	9	13	0	42	1	33	76	501
13:00	0	5	119	36	160	0	34	144	4	182	0	3	2	2	7	0	33	0	28	61	410
14:00	0	4	159	25	188	0	33	186	1	220	0	3	1	1	5	0	22	0	25	47	460
15:00	0	2	159	53	214	0	50	292	9	351	0	5	2	3	10	0	51	1	36	88	663
16:00	0	4	164	40	208	0	58	341	3	402	0	4	0	3	7	0	36	2	51	89	706
17:00	0	6	175	49	230	0	48	414	7	469	0	3	2	1	6	0	33	2	54	89	794
18:00	0	9	141	36	186	0	38	438	9	485	0	4	4	4	12	0	60	1	45	106	789
TOTAL	0	40	2624	732	3396	0	507	2589	52	3148	0	62	21	39	122	0	374	10	409	793	7459
AMPEAK	0	1	469	142	612	0	47	139	2	188	0	10	3	2	15	0	18	2	27	47	862
PMPEAK	0	6	175	49	230	0	48	414	7	469	0	3	2	1	6	0	33	2	54	89	794
DAYPEAK	0	1	469	142	612	0	47	139	2	188	0	10	3	2	15	0	18	2	27	47	862



Maryland Department of Transportation
 State Highway Administration
 Data Services Division
 Turning Movement Summary Report

Station ID: S2002150006

County: Montgomery

Comments: LOS AM:A PM:A

Date: 1/22/2008 6:00:00 AM

Town: none

Location: MD 186 at E BRADLEY LA

Weather:

Interval: 60 Min

PEAK	AM PERIOD	Start	End	Volume	LOS	V/C	PM PERIOD	Start	End	Volume	LOS	V/C
Hours	6:00AM-12:00PM	08:00	09:00	862	N/A	N/A	12:00PM-19:00PM	17:00	18:00	794	N/A	N/A

MD 186

MD 186

EAST BRADLEY LANE

EAST BRADLEY LANE

From North

From South

From East

From West

Begin Hour	From North			From South			From East			From West		
	School Children	Pedestrians	Bicycles	School Children	Pedestrians	Bicycles	School Children	Pedestrians	Bicycles	School Children	Pedestrians	Bicycles
06:00	0	0		0	1		0	15		0	0	
07:00	0	0		0	0		0	1		0	1	
08:00	0	0		0	0		0	3		0	0	
09:00	0	0		0	0		0	5		0	0	
10:00	0	0		0	0		0	1		0	0	
11:00	0	0		0	0		0	2		0	2	
12:00	0	0		0	2		0	2		0	0	
13:00	0	0		0	0		0	2		0	0	
14:00	0	0		0	0		0	0		0	0	
15:00	0	1		0	0		0	5		0	0	
16:00	0	0		0	0		0	0		0	3	
17:00	0	0		0	0		0	1		0	0	
18:00	0	1		0	0		0	1		0	1	
TOTAL	0	2		0	3		0	38		0	7	
AMPEAK	0	0		0	0		0	3		0	0	
PMPEAK	0	0		0	0		0	1		0	0	
DAYPEAK	0	0		0	0		0	3		0	0	



Maryland Department of Transportation
 State Highway Administration
 Data Services Division
 Turning Movement Summary Report

Station ID: S2002150006

County: Montgomery

Comments: LOS AM:A PM:A

Date: 1/22/2008 6:00:00 AM

Town: none

Location: MD 186 at E BRADLEY LA

Weather:

Interval: 60 Min

PEAK	AM PERIOD	Start	End	Volume	LOS	V/C	PM PERIOD	Start	End	Volume	LOS	V/C
Hours	6:00AM-12:00PM	08:00	09:00	862	N/A	N/A	12:00PM-19:00PM	17:00	18:00	794	N/A	N/A

MD 186

MD 186

EAST BRADLEY LANE

EAST BRADLEY LANE

From North

From South

From East

From West

Turning Movement Summary

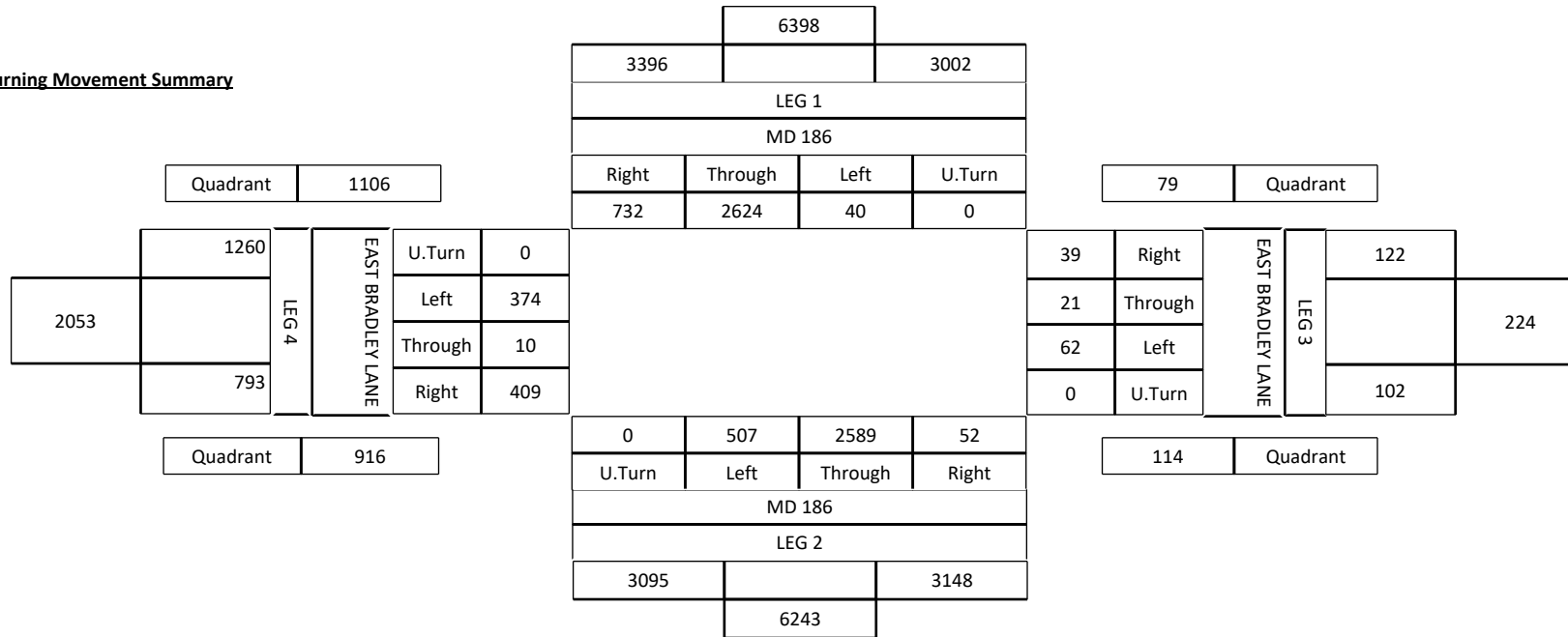



Maryland Department of Transportation
 State Highway Administration
 Data Services Division
 Turning Movement Summary Report

Station ID: S2002150006

County: Montgomery

Comments: LOS AM:A PM:A

Date: 1/22/2008 6:00:00 AM

Town: none

Location: MD 186 at E BRADLEY LA

Weather:

Interval: 60 Min

PEAK	AM PERIOD	Start	End	Volume	LOS	V/C	PM PERIOD	Start	End	Volume	LOS	V/C
Hours	6:00AM-12:00PM	08:00	09:00	862	N/A	N/A	12:00PM-19:00PM	17:00	18:00	794	N/A	N/A

MD 186

MD 186

EAST BRADLEY LANE

EAST BRADLEY LANE

From North

From South

From East

From West

AM Peak Hour

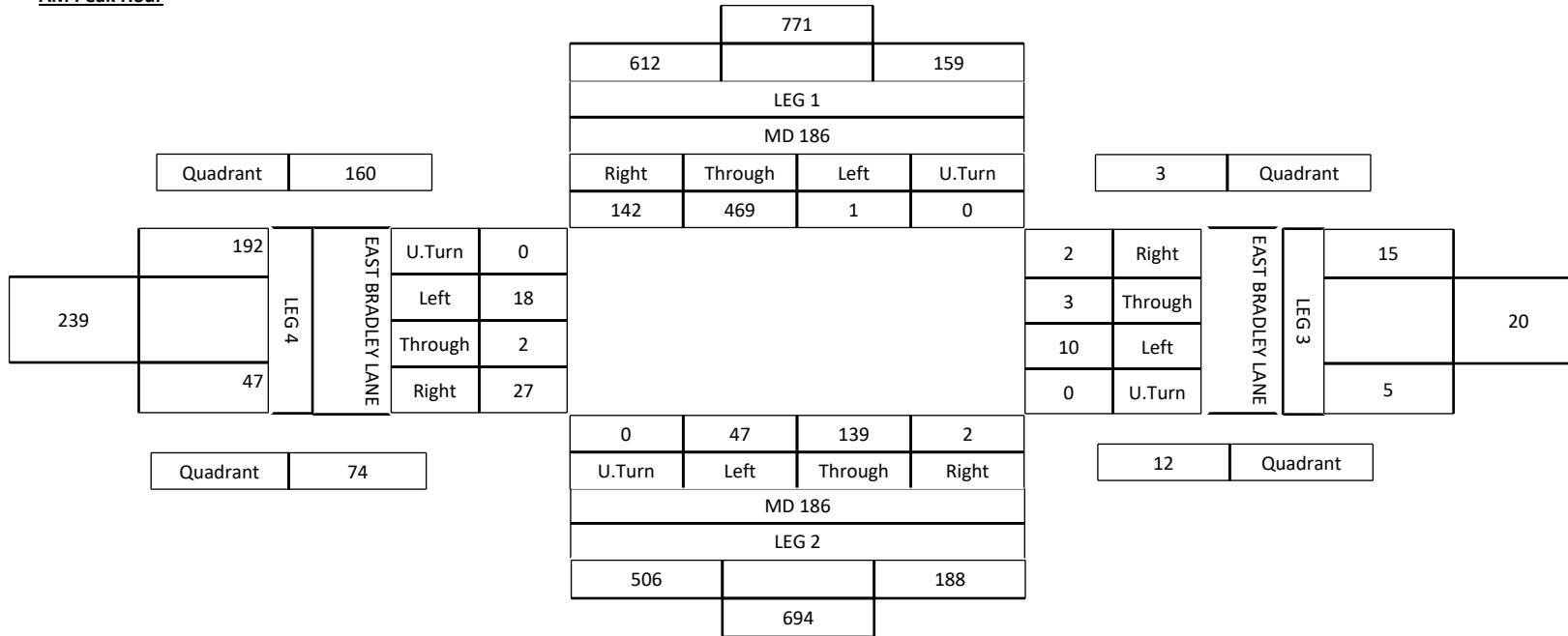



Maryland Department of Transportation
 State Highway Administration
 Data Services Division
 Turning Movement Summary Report

Station ID: S2002150006

County: Montgomery

Comments: LOS AM:A PM:A

Date: 1/22/2008 6:00:00 AM

Town: none

Location: MD 186 at E BRADLEY LA

Weather:

Interval: 60 Min

PEAK	AM PERIOD	Start	End	Volume	LOS	V/C	PM PERIOD	Start	End	Volume	LOS	V/C
Hours	6:00AM-12:00PM	08:00	09:00	862	N/A	N/A	12:00PM-19:00PM	17:00	18:00	794	N/A	N/A

MD 186

MD 186

EAST BRADLEY LANE

EAST BRADLEY LANE

From North

From South

From East

From West

PM Peak Hour

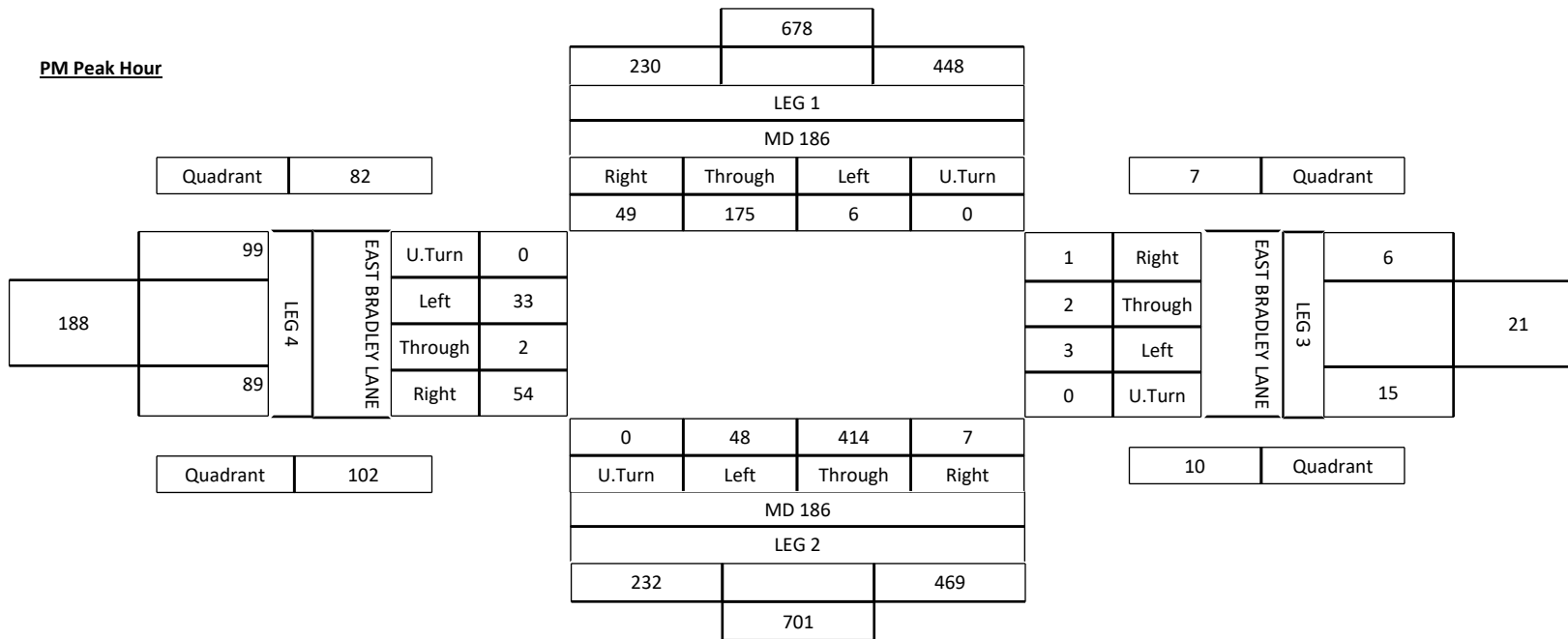



Maryland Department of Transportation
 State Highway Administration
 Data Services Division
 Turning Movement Summary Report

Station ID: S2002150006

County: Montgomery

Comments: LOS AM:A PM:A

Date: 1/22/2008 6:00:00 AM

Town: none

Location: MD 186 at E BRADLEY LA

Weather:

Interval: 60 Min

PEAK	AM PERIOD	Start	End	Volume	LOS	V/C	PM PERIOD	Start	End	Volume	LOS	V/C
Hours	6:00AM-12:00PM	08:00	09:00	862	N/A	N/A	12:00PM-19:00PM	17:00	18:00	794	N/A	N/A

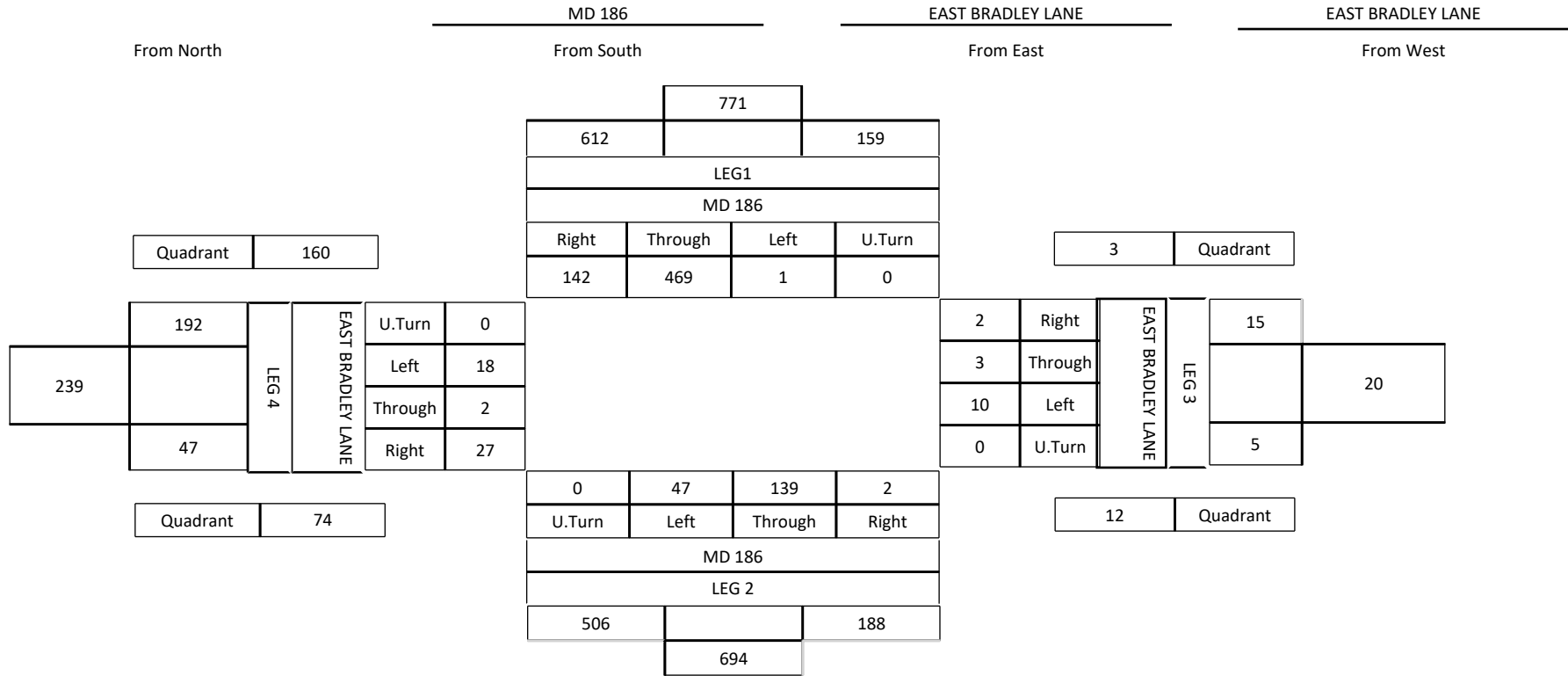

Traffic Counts Report (15 Min Interval)

Intersection: Connecticut Ave at Bradley Ln

Count Date: Wednesday, 5/15/2019

Count Source: SABRA ASSOCIATES



AM Start Time	AM Peak Hour	AM Peak CLV	AM Peak Delay	PM End Time	PM Peak Hour	PM Peak CLV
06:30	07:30 to 08:30	1386		19:00	16:15 to 17:15	1221

PM Peak Delay

	NORTH BOUND				SOUTH BOUND				EAST BOUND				WEST BOUND				OTHER BOUND			
	CONNECTICUT AVE (MD 185)				CONNECTICUT AVE (MD 185)				BRADLEY LA (MD 191)				BRADLEY LA (MD 191)							
START TIME	L	T	R	O	L	T	R	O	L	T	R	O	L	T	R	O	L	T	R	O
06:30	17	118	1	0	0	418	75	0	18	0	19	0	2	7	0	0	0	0	0	0
06:45	26	154	0	0	0	367	66	0	16	7	27	0	3	23	2	0	0	0	0	0
07:00	27	182	0	0	0	426	49	0	28	9	31	0	8	26	1	0	0	0	0	0
07:15	26	230	0	0	0	436	69	0	25	10	27	0	9	23	2	0	0	0	0	0
07:30	36	254	1	0	0	474	52	0	31	9	23	0	8	41	8	0	0	0	0	0
07:45	25	297	1	0	0	521	46	0	30	12	27	0	5	34	5	0	0	0	0	0
08:00	33	293	0	0	0	480	35	0	25	11	27	0	5	41	6	0	0	0	0	0
08:15	27	346	2	0	0	492	49	0	27	9	29	0	16	36	2	0	0	0	0	0
08:30	48	321	0	0	0	471	47	0	28	13	24	0	11	37	1	0	0	0	0	0
08:45	34	324	0	0	0	467	42	0	21	16	25	0	12	44	4	0	0	0	0	0
09:00	32	304	1	0	0	405	50	0	27	14	23	0	10	42	2	0	0	0	0	0
09:15	43	265	1	0	0	319	62	0	28	13	19	0	6	39	5	0	0	0	0	0
11:00	33	238	2	0	0	287	49	0	42	21	40	0	5	20	5	0	0	0	0	0
11:15	36	219	5	0	0	271	50	0	43	28	23	0	6	24	1	0	0	0	0	0
11:30	26	233	1	0	0	259	61	0	57	24	32	0	1	16	7	0	0	0	0	0
11:45	29	220	3	0	0	228	64	0	42	21	31	0	5	30	1	0	0	0	0	0
12:00	26	279	3	0	0	271	55	0	53	14	28	0	2	25	2	0	0	0	0	0
12:15	42	279	2	0	0	229	48	0	52	9	29	0	1	26	3	0	0	0	0	0
12:30	32	293	3	0	0	253	63	0	61	12	34	0	3	18	8	0	0	0	0	0
12:45	53	268	0	0	0	211	62	0	53	17	32	0	3	20	3	0	0	0	0	0
16:00	27	285	0	0	0	274	47	0	66	26	18	0	3	30	5	0	0	0	0	0
16:15	26	349	0	0	0	289	41	0	73	20	14	0	4	22	16	0	0	0	0	0
16:30	26	435	0	0	0	325	33	0	59	25	24	0	9	19	13	0	0	0	0	0
16:45	36	351	0	0	0	295	45	0	73	19	20	0	2	17	12	0	0	0	0	0
17:00	41	396	1	0	0	320	45	0	66	18	14	0	3	26	3	0	0	0	0	0
17:15	46	372	0	0	0	265	51	0	54	23	21	0	2	35	5	0	0	0	0	0
17:30	38	359	2	0	0	307	41	0	64	22	30	0	2	33	3	0	0	0	0	0
17:45	39	333	1	0	0	291	54	0	63	34	22	0	5	31	4	0	0	0	0	0
18:00	44	315	4	0	0	267	28	0	48	21	45	0	2	26	3	0	0	0	0	0
18:15	45	321	2	0	0	292	41	0	60	26	32	0	5	23	3	0	0	0	0	0
18:30	58	293	1	0	0	255	34	0	54	23	43	0	1	23	3	0	0	0	0	0
18:45	46	293	0	0	0	255	33	0	51	33	38	0	2	19	4	0	0	0	0	0
Total	1123	9219	37	0	0	10720	1587	0	1438	559	871	0	161	876	142	0	0	0	0	0

Traffic Counts Report (30 Min Interval)

Intersection: Connecticut Ave at Bradley Ln

Count Date: Wednesday, 5/15/2019

Count Source: SABRA ASSOCIATES



AM Start Time	PM End Time
06:30	19:00

START TIME	NORTH BOUND				SOUTH BOUND				EAST BOUND				WEST BOUND				OTHER BOUND			
	CONNECTICUT AVE (MD 185)				CONNECTICUT AVE (MD 185)				BRADLEY LA (MD 191)				BRADLEY LA (MD 191)							
	L	T	R	O	L	T	R	O	L	T	R	O	L	T	R	O	L	T	R	O
06:30	43	272	1	0	0	785	141	0	34	7	46	0	5	30	2	0	0	0	0	0
07:00	53	412	0	0	0	862	118	0	53	19	58	0	17	49	3	0	0	0	0	0
07:30	61	551	2	0	0	995	98	0	61	21	50	0	13	75	13	0	0	0	0	0
08:00	60	639	2	0	0	972	84	0	52	20	56	0	21	77	8	0	0	0	0	0
08:30	82	645	0	0	0	938	89	0	49	29	49	0	23	81	5	0	0	0	0	0
09:00	75	569	2	0	0	724	112	0	55	27	42	0	16	81	7	0	0	0	0	0
16:00	53	634	0	0	0	563	88	0	139	46	32	0	7	52	21	0	0	0	0	0
16:30	62	786	0	0	0	620	78	0	132	44	44	0	11	36	25	0	0	0	0	0
17:00	87	768	1	0	0	585	96	0	120	41	35	0	5	61	8	0	0	0	0	0
17:30	77	692	3	0	0	598	95	0	127	56	52	0	7	64	7	0	0	0	0	0
18:00	89	636	6	0	0	559	69	0	108	47	77	0	7	49	6	0	0	0	0	0
18:30	104	586	1	0	0	510	67	0	105	56	81	0	3	42	7	0	0	0	0	0
Total	846	7190	18	0	0	8711	1135	0	1035	413	622	0	135	697	112	0	0	0	0	0

Traffic Counts Report (60 Min Interval)

Intersection: Connecticut Ave at Bradley Ln

Count Date: Wednesday, 5/15/2019

Count Source: SABRA ASSOCIATES



AM Start Time	PM End Time
06:30	19:00

START TIME	NORTH BOUND				SOUTH BOUND				EAST BOUND				WEST BOUND				OTHER BOUND			
	CONNECTICUT AVE (MD 185)				CONNECTICUT AVE (MD 185)				BRADLEY LA (MD 191)				BRADLEY LA (MD 191)							
	L	T	R	O	L	T	R	O	L	T	R	O	L	T	R	O	L	T	R	O
06:30	96	684	1	0	0	1647	259	0	87	26	104	0	22	79	5	0	0	0	0	0
07:30	121	1190	4	0	0	1967	182	0	113	41	106	0	34	152	21	0	0	0	0	0
08:30	157	1214	2	0	0	1662	201	0	104	56	91	0	39	162	12	0	0	0	0	0
16:00	115	1420	0	0	0	1183	166	0	271	90	76	0	18	88	46	0	0	0	0	0
17:00	164	1460	4	0	0	1183	191	0	247	97	87	0	12	125	15	0	0	0	0	0
18:00	193	1222	7	0	0	1069	136	0	213	103	158	0	10	91	13	0	0	0	0	0
Total	846	7190	18	0	0	8711	1135	0	1035	413	622	0	135	697	112	0	0	0	0	0



APPENDIX B – Existing CLV

Maryland State Highway Administration
Turning Movement Summary and Level of Service

Prepared by: Mead & Hunt

Count Date:

Location: MD 410 at MD 186

Conditions: Existing

Design Year:

Computed by: JC

Date 5/31/2022

Morning Peak Hour: 7:45 AM - 8:45 AM

Evening Peak Hour: 4:30 - 5:30 PM

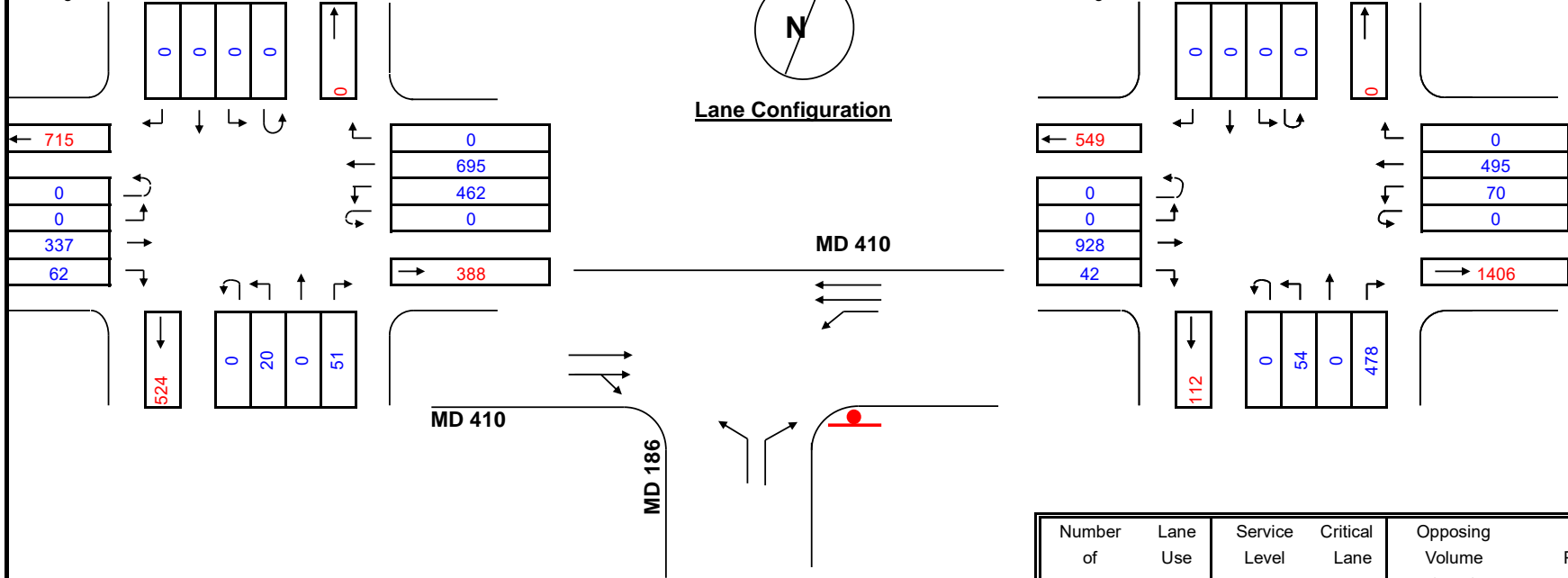

Phasing			

- RTOR/Overlap
- Northbound
 - Southbound
 - Eastbound
 - Westbound

- Split Phasing
- East/West
 - North/South
 - None

- Inx. Control
- Signal
 - Stop

Number of Lanes	Lane Use Factor	Service Level	Critical Lane Vol	Opposing Volume (VPH)	PCE
1	= 1.00	A	<= 1000	<= 199	1.1
2	= 0.53	B	<= 1150	<= 599	2.0
3	= 0.37	C	<= 1300	<= 799	3.0
4	= 0.25	D	<= 1450	<= 999	4.0
Dbt-Lt = 0.60		E	<= 1600	> 1000	5.0
		F	> 1600		

Phase	Movement	Volume 1	Lane Use Factor - 2	Lane volume 1 X 2	Opposing Movement	Critical In. volume	*	Phase	Movement	Volume 1	Lane Use Factor - 2	Lane volume 1 X 2	Opposing Movement	Critical In. Volume	*
	NB	20	1.00	20	0	20	*		NB	408	1.00	408	0	408	*
	SB	0	0.00	0	0	0			SB	0	0.00	0	0	0	
	EB	399	0.53	211	462	673	*		EB	970	0.53	514	70	584	*
	WB	695	0.53	368	0	368			WB	495	0.53	262	0	262	

Remarks: * Critical volume Total **693**
Level of service (V/C) **0.43** **A**

Remarks: * Critical volume Total **992**
Level of service (V/C) **0.62** **A**

Maryland State Highway Administration
Turning Movement Summary and Level of Service

Prepared by: Mead & Hunt

Count Date:

Location: MD 410 at MD 185

Conditions: Existing

Design Year:

Computed by: JC

Date 5/31/2022

Morning Peak Hour: 7:45 AM - 8:45 AM

Evening Peak Hour: 5:30-6:30 PM

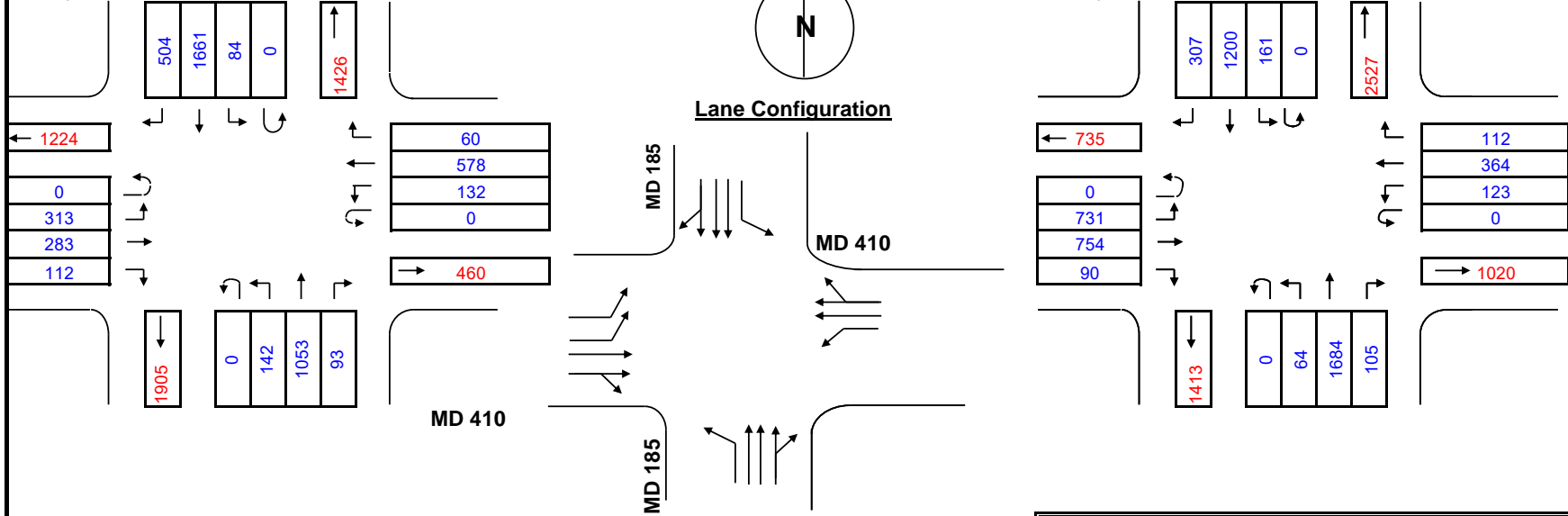

Number of Lanes	Lane Use Factor	Service Level	Critical Lane Vol	Opposing Volume (VPH)	PCE
1	= 1.00	A	<= 1000	<= 199	1.1
2	= 0.53	B	<= 1150	<= 599	2.0
3	= 0.37	C	<= 1300	<= 799	3.0
4	= 0.25	D	<= 1450	<= 999	4.0
DbI-Lt = 0.60		E	<= 1600	> 1000	5.0
		F	> 1600		

Phasing

RTOR/Overlap
 Northbound
 Southbound
 Eastbound
 Westbound

Split Phasing
 East/West
 North/South
 None

Inx. Control
 Signal
 Stop

Phase	Movement	Volume 1	Lane Use Factor - 2	Lane volume 1 X 2	Opposing Movement	Critical In. volume	*	Phase	Movement	Volume 1	Lane Use Factor - 2	Lane volume 1 X 2	Opposing Movement	Critical In. Volume	*
	NB	1146	0.37	424	84	508			NB	1789	0.37	662	161	823	*
	SB	2165	0.37	801	142	943	*		SB	1507	0.37	558	64	622	
	EB	395	0.53	209	132	341			EB	844	0.53	447	123	570	
	WB	638	0.53	338	188	526	*		WB	476	0.53	252	438.6	691	*

Remarks:	* Critical volume	Total	1469	Level of service (V/C)	0.92	E	Remarks:	* Critical volume	Total	1514	Level of service (V/C)	0.95	E
----------	-------------------	-------	------	------------------------	------	---	----------	-------------------	-------	------	------------------------	------	---

Count Date:

Location: MD 186 at Leland St

Conditions: Existing

Design Year:

Computed by: JC

Date 5/31/2022

Morning Peak Hour: 8:00 AM - 9:00 AM

Evening Peak Hour: 5:00-6:00 PM

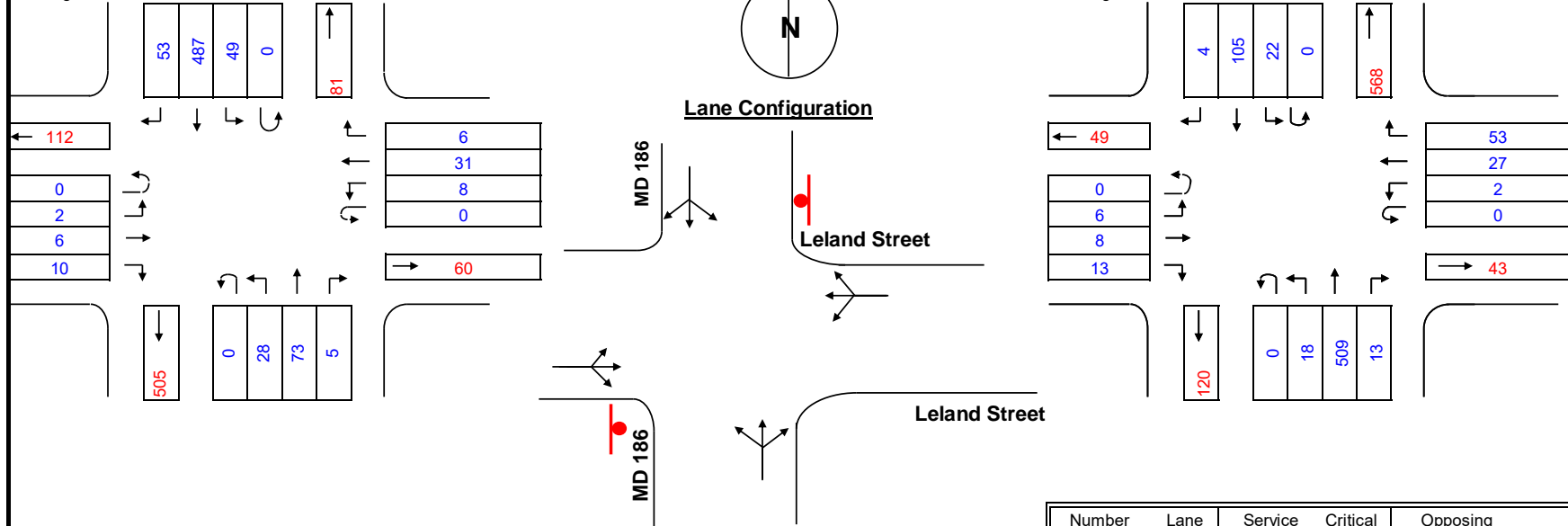

Phasing			

- RTOR/Overlap
- Northbound
 - Southbound
 - Eastbound
 - Westbound

- Split Phasing
- East/West
 - North/South
 - None

- Inx. Control
- Signal
 - Stop

Number of Lanes	Lane Use Factor	Service Level	Critical Lane Vol	Opposing Volume (VPH)	PCE
1	1.00	A	<= 1000	<= 199	1.1
2	0.53	B	<= 1150	<= 599	2.0
3	0.37	C	<= 1300	<= 799	3.0
4	0.25	D	<= 1450	<= 999	4.0
Dbl-Lt = 0.60		E	<= 1600	> 1000	5.0
		F	> 1600		

Phase	Movement	Volume 1	Lane Use Factor - 2	Lane volume 1 X 2	Opposing Movement	Critical In. volume	*	Phase	Movement	Volume 1	Lane Use Factor - 2	Lane volume 1 X 2	Opposing Movement	Critical In. Volume	*
	NB	134	1.00	134	49	183	*		NB	542	1.00	542	22	564	*
	SB	594	1.00	594	28	622	*		SB	65	1.00	65	18	83	
	EB	18	1.00	18	8	26			EB	28	1.00	28	2	30	
	WB	46	1.00	46	2	48	*		WB	82	1.00	82	6	88	*

Remarks: * Critical volume Total **670**
Level of service (V/C) **0.42** **A**

Remarks: * Critical volume Total **652**
Level of service (V/C) **0.41** **A**

Maryland State Highway Administration
Turning Movement Summary and Level of Service

Prepared by: Mead & Hunt

Count Date:

Location: MD 185 at Leland St

Conditions: Existing

Design Year:

Computed by: JC

Date 5/31/2022

Morning Peak Hour: 8:00 AM - 9:00 AM

Evening Peak Hour: 5:15-6:15 PM

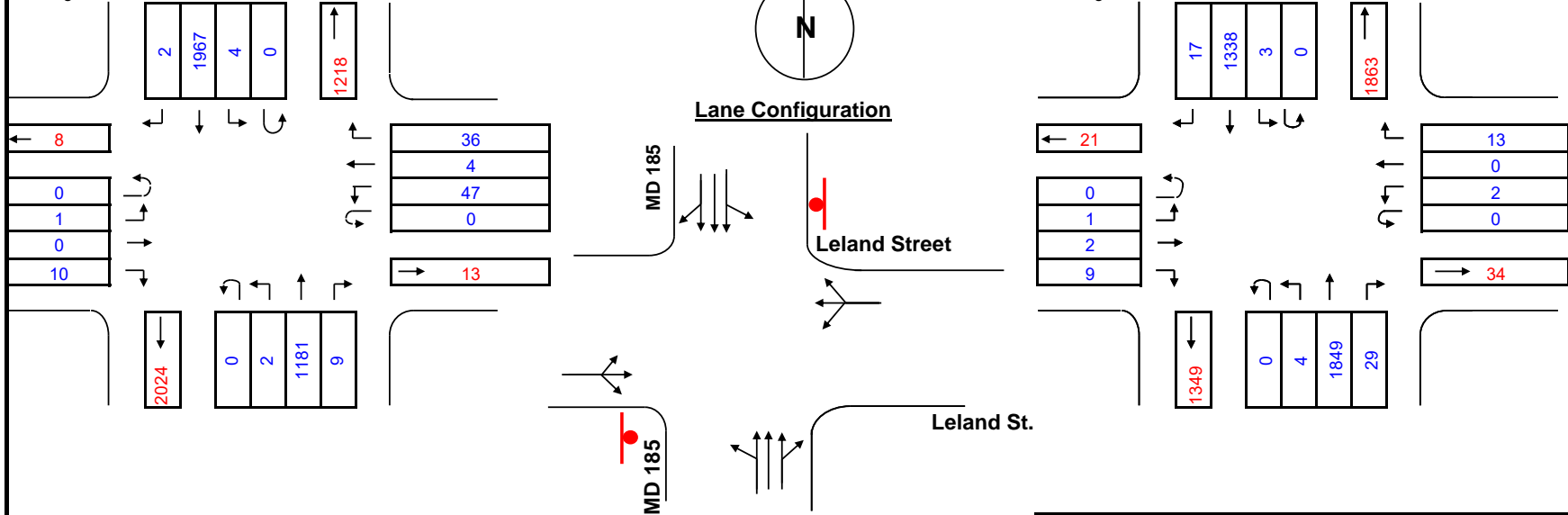

Number of Lanes	Lane Use Factor	Service Level	Critical Lane Vol	Opposing Volume (VPH)	PCE
1	= 1.00	A	<= 1000	<= 199	1.1
2	= 0.53	B	<= 1150	<= 599	2.0
3	= 0.37	C	<= 1300	<= 799	3.0
4	= 0.25	D	<= 1450	<= 999	4.0
Dbt-Lt = 0.60		E	<= 1600	> 1000	5.0
		F	> 1600		

Phasing			

Phase	Movement	Volume 1	Lane Use Factor - 2	Lane volume 1 X 2	Opposing Movement	Critical In. volume	*	Phase	Movement	Volume 1	Lane Use Factor - 2	Lane volume 1 X 2	Opposing Movement	Critical In. Volume	*
	NB	1200	0.37	444	4	448			NB	1898	0.37	702	3	705	*
	SB	1989	0.37	736	2	738	*		SB	1370	0.37	507	4	511	
	EB	11	1.00	11	47	58			EB	12	1.00	12	2	14	
	WB	92	1.00	92	1	93	*		WB	15	1.00	15	1	16	*

Remarks:	* Critical volume	Total	831	Level of service (V/C)	0.52	A	Remarks:	* Critical volume	Total	721	Level of service (V/C)	0.45	A
----------	-------------------	-------	-----	------------------------	------	---	----------	-------------------	-------	-----	------------------------	------	---

Count Date:

Location: MD 186 at Bradley Ln

Conditions: Existing

Computed by: JC

Date 5/31/2022

Design Year:

Morning Peak Hour: 8:00 AM - 9:00 AM

Evening Peak Hour: 5:00-6:00 PM

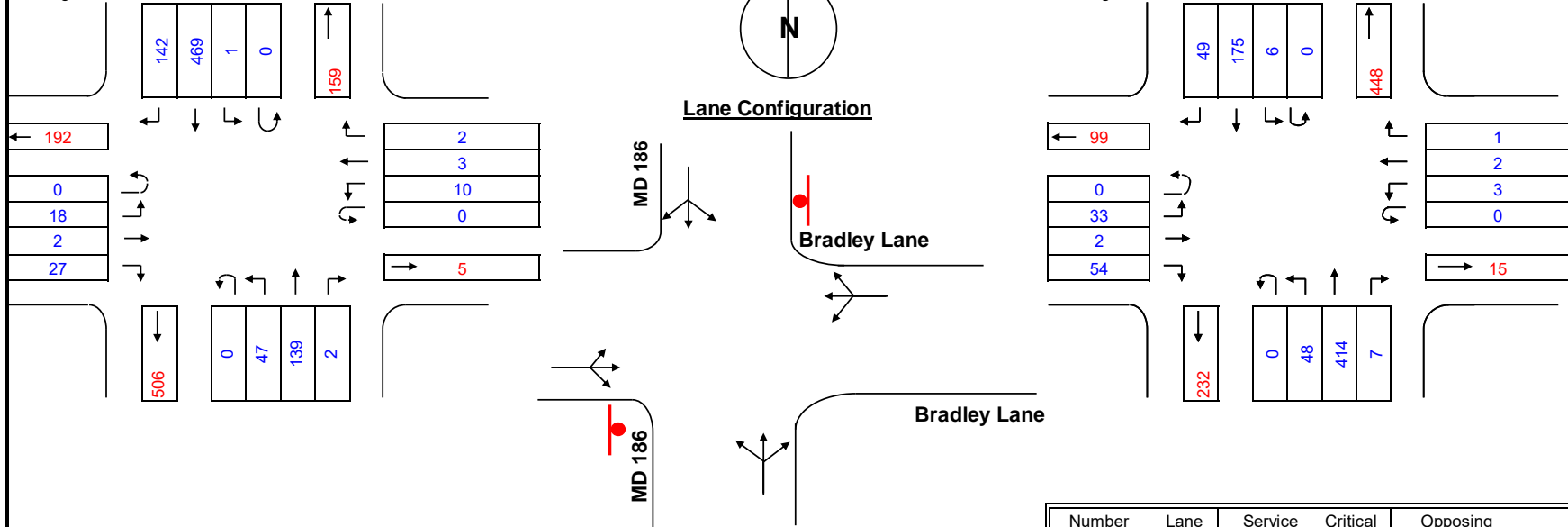

Number of Lanes	Lane Use Factor	Service Level	Critical Lane Vol	Opposing Volume (VPH)	PCE
1	1.00	A	<= 1000	<= 199	1.1
2	0.53	B	<= 1150	<= 599	2.0
3	0.37	C	<= 1300	<= 799	3.0
4	0.25	D	<= 1450	<= 999	4.0
Dbl-Lt = 0.60		E	<= 1600	> 1000	5.0
		F	> 1600		

Phasing			
Phase	Movement	Volume	Lane Use Factor - 2

- RTOR/Overlap
- Northbound
 - Southbound
 - Eastbound
 - Westbound

- Split Phasing
- East/West
 - North/South
 - None

- Inx. Control
- Signal
 - Stop

Phase	Movement	Volume	Lane Use Factor - 2	Lane volume 1 X 2	Opposing Movement	Critical In. volume	*	Phase	Movement	Volume	Lane Use Factor - 2	Lane volume 1 X 2	Opposing Movement	Critical In. Volume	*
	NB	282	1.00	282	1	283			NB	517	1.00	517	6	523	*
	SB	612	1.00	612	47	659	*		SB	212	1.00	212	48	260	
	EB	49	1.00	49	10	59	*		EB	92	1.00	92	3	95	*
	WB	16	1.00	16	18	34			WB	6	1.00	6	33	39	

Remarks: * Critical volume Total **718**
Level of service (V/C) **0.45** **A**

Remarks: * Critical volume Total **618**
Level of service (V/C) **0.39** **A**

Maryland State Highway Administration
Turning Movement Summary and Level of Service

Prepared by: Mead & Hunt

Count Date:

Location: MD 185 at Bradley Ln

Conditions: Existing

Design Year:

Computed by: JC

Date 5/31/2022

Morning Peak Hour: 7:30 AM - 8:30 AM

Evening Peak Hour: 4:15-5:15 PM

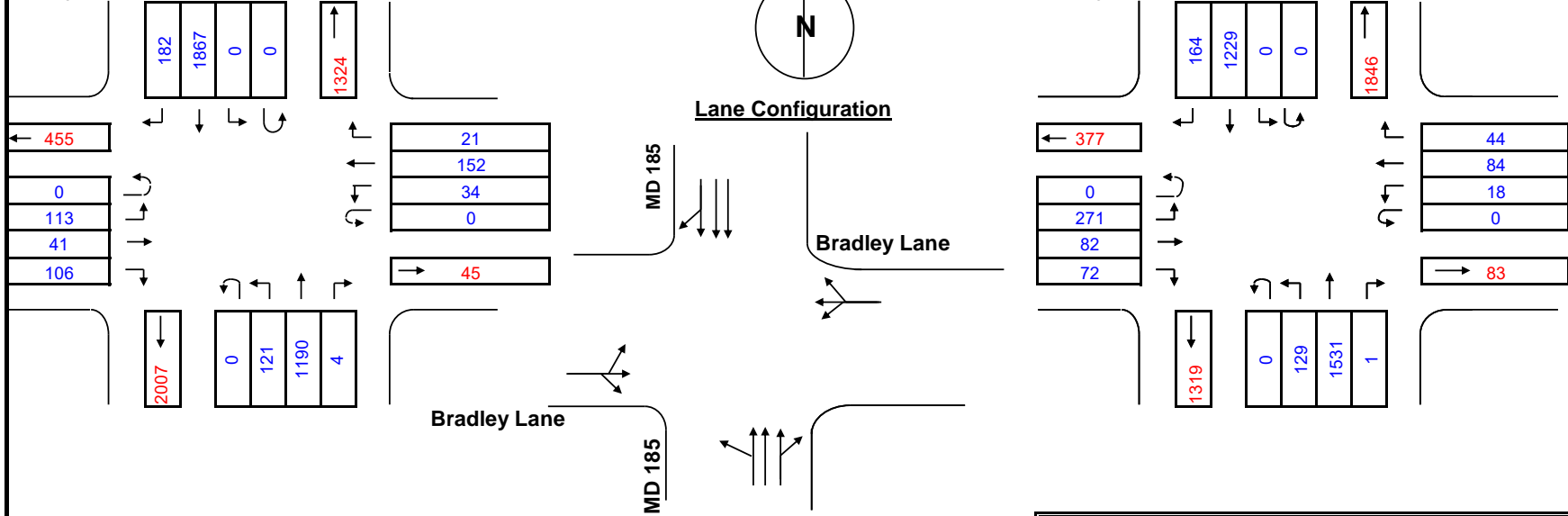

Number of Lanes	Lane Use Factor	Service Level	Critical Lane Vol	Opposing Volume (VPH)	PCE
1	1.00	A	<= 1000	<= 199	1.1
2	0.53	B	<= 1150	<= 599	2.0
3	0.37	C	<= 1300	<= 799	3.0
4	0.25	D	<= 1450	<= 999	4.0
Dbl-Lt = 0.60		E	<= 1600	> 1000	5.0
		F	> 1600		

Phasing

RTOR/Overlap

- Northbound
- Southbound
- Eastbound
- Westbound

Split Phasing

- East/West
- North/South
- None

Inx. Control

- Signal
- Stop

Phase	Movement	Volume 1	Lane Use Factor - 2	Lane volume 1 X 2	Opposing Movement	Critical In. volume	*	Phase	Movement	Volume 1	Lane Use Factor - 2	Lane volume 1 X 2	Opposing Movement	Critical In. Volume	*
	NB	1799	0.37	666	0	666			NB	2177	0.37	805	0	805	*
	SB	2049	0.37	758	121	879	*		SB	1393	0.37	515	129	644	
	EB	260	1.00	260	0	260	*		EB	425	1.00	425	0	425	*
	WB	207	1.00	207	0	207	*		WB	146	1.00	146	0	146	*

Remarks:	* Critical volume	Total	1346	Remarks:	* Critical volume	Total	1376
	Level of service (V/C)		0.84		Level of service (V/C)		

APPENDIX C – Travel Times

Leland Street	
Run	Morning Peak Hour Westbound Time (min:sec)
1	0:04:10
2	0:04:05
3	0:04:53
4	0:03:24
5	0:04:07
Average	0:04:08

MD 410	
Run	Morning Peak Hour Westbound Time (min:sec)
1	0:03:58
2	0:03:05
3	0:09:03
4	0:08:01
5	0:06:18
Average	0:06:05



APPENDIX D – Diverted Traffic CLV

Maryland State Highway Administration
Turning Movement Summary and Level of Service

Prepared by: Mead & Hunt

Count Date:

Location: MD 410 at MD 186

Conditions: Proposed

Design Year:

Computed by: JC

Date 5/31/2022

Morning Peak Hour: 7:45 AM - 8:45 AM

Evening Peak Hour: 4:30 - 5:30 PM

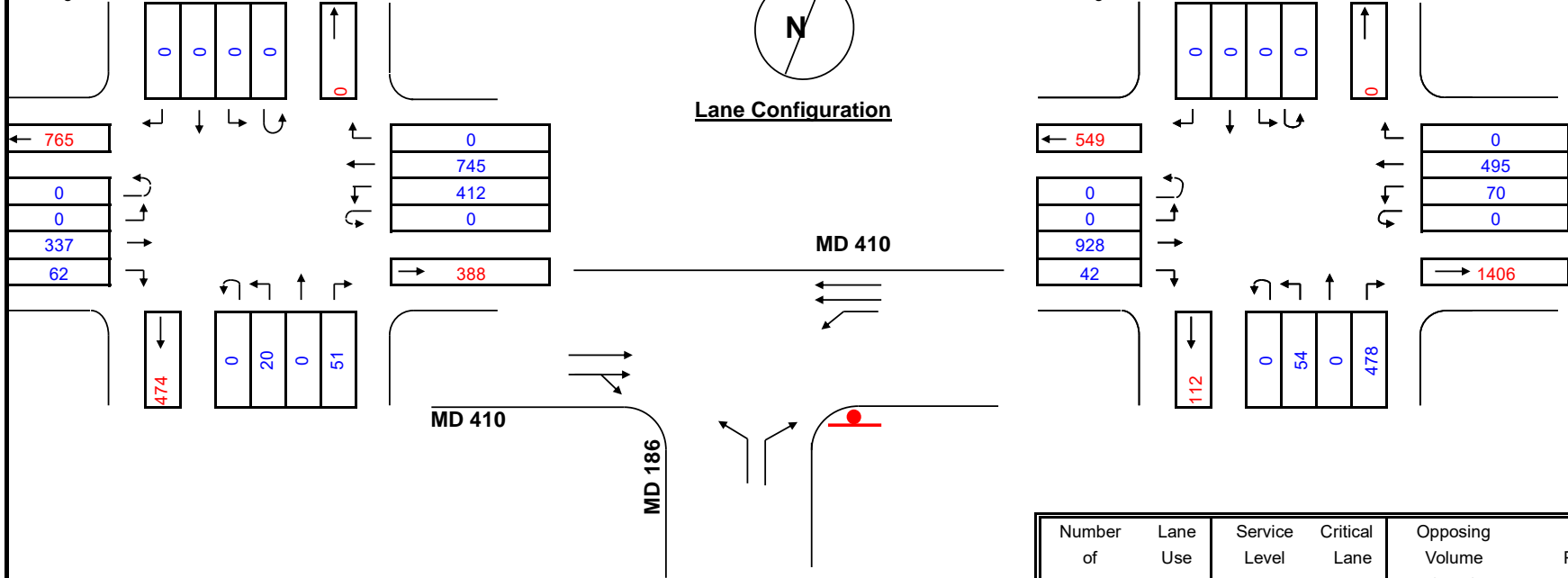

Phasing			

- RTOR/Overlap
- Northbound
 - Southbound
 - Eastbound
 - Westbound

- Split Phasing
- East/West
 - North/South
 - None

- Inx. Control
- Signal
 - Stop

Number of Lanes	Lane Use Factor	Service Level	Critical Lane Vol	Opposing Volume (VPH)	PCE
1	= 1.00	A	<= 1000	<= 199	1.1
2	= 0.53	B	<= 1150	<= 599	2.0
3	= 0.37	C	<= 1300	<= 799	3.0
4	= 0.25	D	<= 1450	<= 999	4.0
Dbt-Lt = 0.60		E	<= 1600	> 1000	5.0
		F	> 1600		

Phase	Movement	Volume 1	Lane Use Factor - 2	Lane volume 1 X 2	Opposing Movement	Critical In. volume	*	Phase	Movement	Volume 1	Lane Use Factor - 2	Lane volume 1 X 2	Opposing Movement	Critical In. Volume	*
	NB	20	1.00	20	0	20	*		NB	408	1.00	408	0	408	*
	SB	0	0.00	0	0	0			SB	0	0.00	0	0	0	
	EB	399	0.53	211	412	623	*		EB	970	0.53	514	70	584	*
	WB	745	0.53	395	0	395			WB	495	0.53	262	0	262	

Remarks: * Critical volume Total **643**
Level of service (V/C) **0.40** **A**

Remarks: * Critical volume Total **992**
Level of service (V/C) **0.62** **A**

Maryland State Highway Administration
Turning Movement Summary and Level of Service

Prepared by: Mead & Hunt

Count Date:

Location: MD 410 at MD 185

Conditions: Proposed

Design Year:

Computed by: JC

Date 5/31/2022

Morning Peak Hour: 7:45 AM - 8:45 AM

Evening Peak Hour: 5:30-6:30 PM

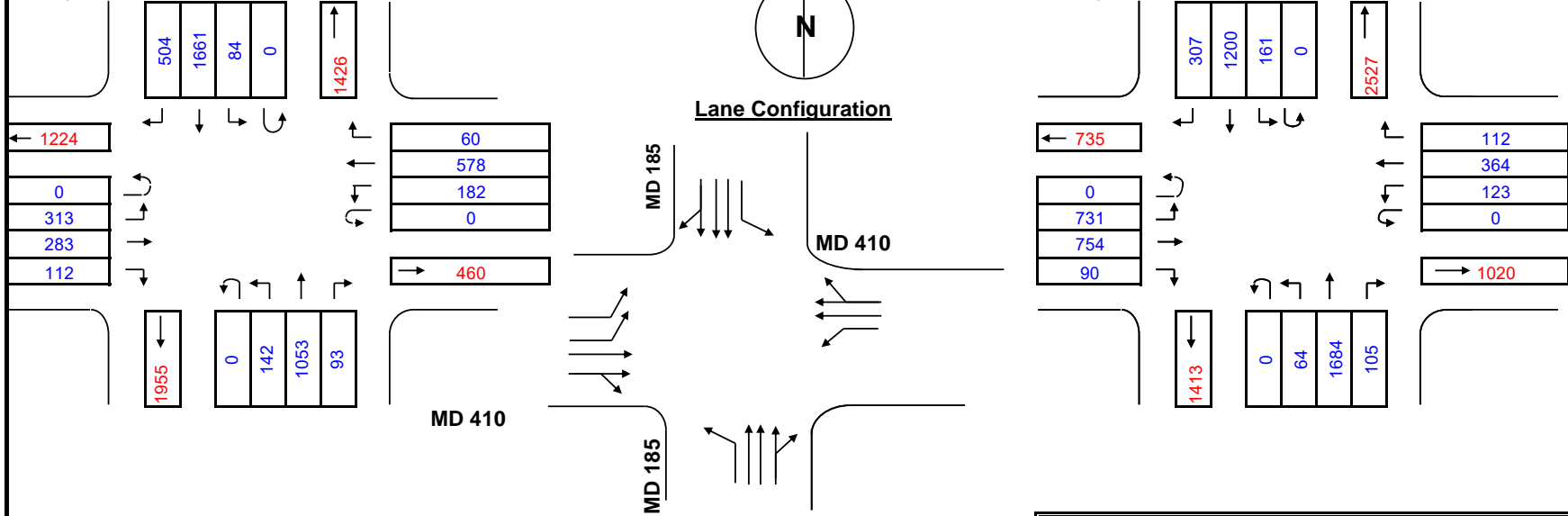

Number of Lanes	Lane Use Factor	Service Level	Critical Lane Vol	Opposing Volume (VPH)	PCE
1	= 1.00	A	<= 1000	<= 199	1.1
2	= 0.53	B	<= 1150	<= 599	2.0
3	= 0.37	C	<= 1300	<= 799	3.0
4	= 0.25	D	<= 1450	<= 999	4.0
DbI-Lt = 0.60		E	<= 1600	> 1000	5.0
		F	> 1600		

Phasing

RTOR/Overlap
 Northbound
 Southbound
 Eastbound
 Westbound

Split Phasing
 East/West
 North/South
 None

Inx. Control
 Signal
 Stop

Phase	Movement	Volume 1	Lane Use Factor - 2	Lane volume 1 X 2	Opposing Movement	Critical In. volume	*	Phase	Movement	Volume 1	Lane Use Factor - 2	Lane volume 1 X 2	Opposing Movement	Critical In. Volume	*
	NB	1146	0.37	424	84	508			NB	1789	0.37	662	161	823	*
	SB	2165	0.37	801	142	943	*		SB	1507	0.37	558	64	622	
	EB	395	0.53	209	182	391			EB	844	0.53	447	123	570	
	WB	638	0.53	338	188	526	*		WB	476	0.53	252	438.6	691	*

Remarks: * Critical volume Total **1469** Level of service (V/C) **0.92** **E** Remarks: * Critical volume Total **1514** Level of service (V/C) **0.95** **E**

Count Date:

Location: MD 186 at Leland St

Conditions: Proposed

Design Year:

Computed by: JC

Date 5/31/2022

Morning Peak Hour: 8:00 AM - 9:00 AM

Evening Peak Hour: 5:00-6:00 PM

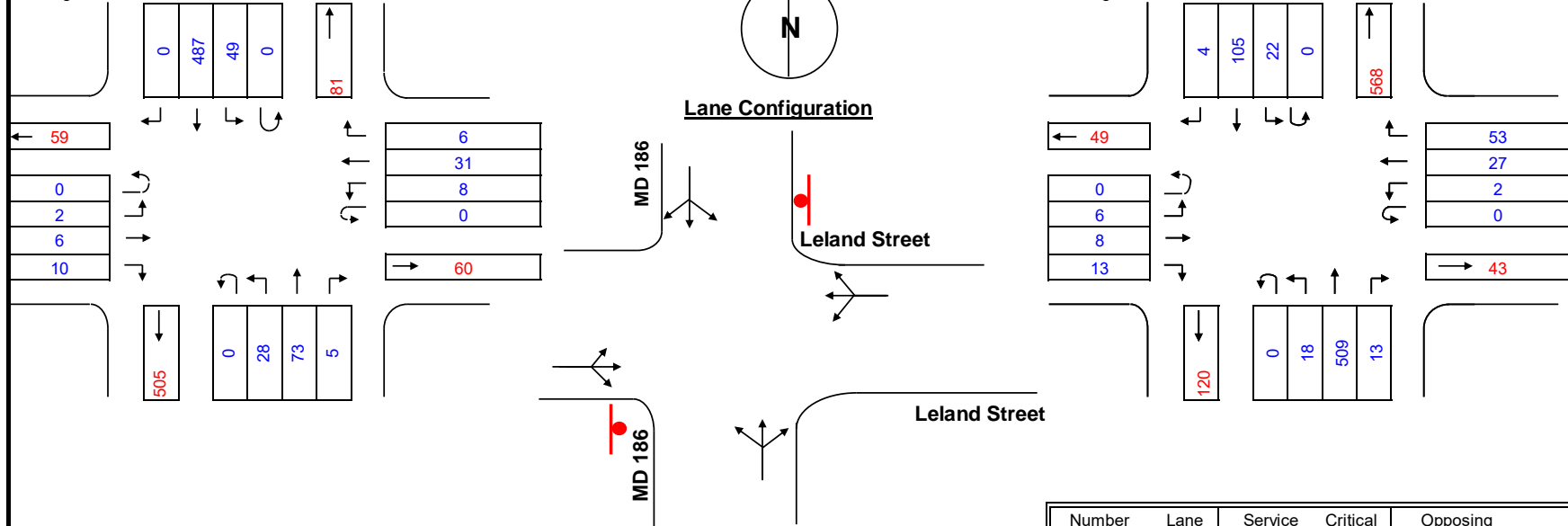

Number of Lanes	Lane Use Factor	Service Level	Critical Lane Vol	Opposing Volume (VPH)	PCE
1	1.00	A	<= 1000	<= 199	1.1
2	0.53	B	<= 1150	<= 599	2.0
3	0.37	C	<= 1300	<= 799	3.0
4	0.25	D	<= 1450	<= 999	4.0
Dbl-Lt = 0.60		E	<= 1600	> 1000	5.0
		F	> 1600		

Phasing			
Phase	Movement	Volume	Lane Use Factor - 2

- RTOR/Overlap
- Northbound
 - Southbound
 - Eastbound
 - Westbound

- Split Phasing
- East/West
 - North/South
 - None

- Inx. Control
- Signal
 - Stop

Phase	Movement	Volume	Lane Use Factor - 2	Lane volume 1 X 2	Opposing Movement	Critical In. volume	*	Phase	Movement	Volume	Lane Use Factor - 2	Lane volume 1 X 2	Opposing Movement	Critical In. Volume	*
	NB	134	1.00	134	49	183	*		NB	542	1.00	542	22	564	*
	SB	541	1.00	541	28	569	*		SB	65	1.00	65	18	83	
	EB	18	1.00	18	8	26			EB	28	1.00	28	2	30	
	WB	46	1.00	46	2	48	*		WB	82	1.00	82	6	88	*

Remarks: * Critical volume Total **617**
Level of service (V/C) **0.39** **A**

Remarks: * Critical volume Total **652**
Level of service (V/C) **0.41** **A**

Count Date:

Location: MD 185 at Leland St

Conditions: Proposed

Design Year:

Computed by: JC

Date 5/31/2022

Morning Peak Hour: 8:00 AM - 9:00 AM

Evening Peak Hour: 5:15-6:15 PM

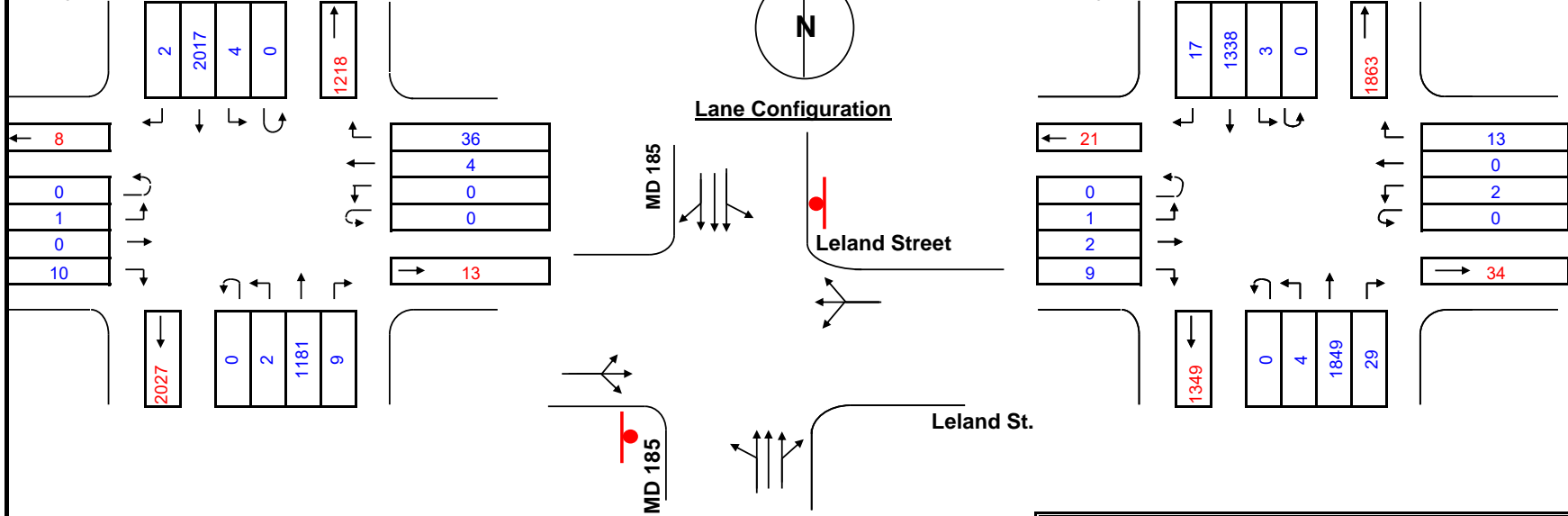

Phasing			

- RTOR/Overlap
- Northbound
 - Southbound
 - Eastbound
 - Westbound

- Split Phasing
- East/West
 - North/South
 - None

- Inx. Control
- Signal
 - Stop

Number of Lanes	Lane Use Factor	Service Level	Critical Lane Vol	Opposing Volume (VPH)	PCE
1	= 1.00	A	<= 1000	<= 199	1.1
2	= 0.53	B	<= 1150	<= 599	2.0
3	= 0.37	C	<= 1300	<= 799	3.0
4	= 0.25	D	<= 1450	<= 999	4.0
Dbl-Lt = 0.60		E	<= 1600	> 1000	5.0
		F	> 1600		

Phase	Movement	Volume 1	Lane Use Factor - 2	Lane volume 1 X 2	Opposing Movement	Critical In. volume	*	Phase	Movement	Volume 1	Lane Use Factor - 2	Lane volume 1 X 2	Opposing Movement	Critical In. Volume	*
	NB	1200	0.37	444	4	448			NB	1898	0.37	702	3	705	*
	SB	2039	0.37	754	2	756	*		SB	1370	0.37	507	4	511	
	EB	11	1.00	11	0	11			EB	12	1.00	12	2	14	
	WB	40	1.00	40	1	41	*		WB	15	1.00	15	1	16	*

Remarks: * Critical volume Total **797**
Level of service (V/C) **0.50** **A**

Remarks: * Critical volume Total **721**
Level of service (V/C) **0.45** **A**

Count Date:

Location: MD 186 at Bradley Ln

Conditions: Proposed

Computed by: JC

Date 5/31/2022

Design Year:

Morning Peak Hour: 8:00 AM - 9:00 AM

Evening Peak Hour: 5:00-6:00 PM

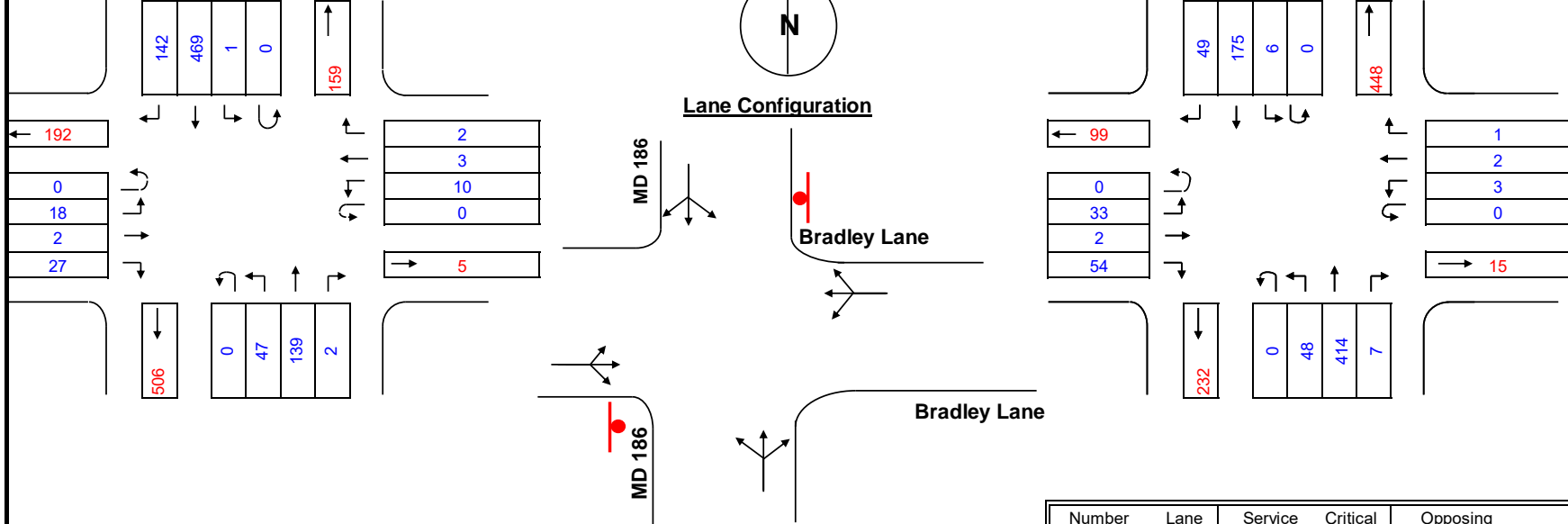

Number of Lanes	Lane Use Factor	Service Level	Critical Lane Vol	Opposing Volume (VPH)	PCE
1	1.00	A	<= 1000	<= 199	1.1
2	0.53	B	<= 1150	<= 599	2.0
3	0.37	C	<= 1300	<= 799	3.0
4	0.25	D	<= 1450	<= 999	4.0
Dbl-Lt = 0.60		E	<= 1600	> 1000	5.0
		F	> 1600		

Phasing			

- RTOR/Overlap
- Northbound
 - Southbound
 - Eastbound
 - Westbound

- Split Phasing
- East/West
 - North/South
 - None

- Inx. Control
- Signal
 - Stop

Phase	Movement	Volume 1	Lane Use Factor - 2	Lane volume 1 X 2	Opposing Movement	Critical In. volume	*	Phase	Movement	Volume 1	Lane Use Factor - 2	Lane volume 1 X 2	Opposing Movement	Critical In. Volume	*
	NB	282	1.00	282	1	283			NB	517	1.00	517	6	523	*
	SB	612	1.00	612	47	659	*		SB	212	1.00	212	48	260	
	EB	49	1.00	49	10	59	*		EB	92	1.00	92	3	95	*
	WB	16	1.00	16	18	34			WB	6	1.00	6	33	39	

Remarks: * Critical volume Total **718**
Level of service (V/C) **0.45** **A**

Remarks: * Critical volume Total **618**
Level of service (V/C) **0.39** **A**

Maryland State Highway Administration
Turning Movement Summary and Level of Service

Prepared by: Mead & Hunt

Count Date:

Location: MD 185 at Bradley Ln

Conditions: Proposed

Design Year:

Computed by: JC

Date 5/31/2022

Morning Peak Hour: 7:30 AM - 8:30 AM

Evening Peak Hour: 4:15-5:15 PM

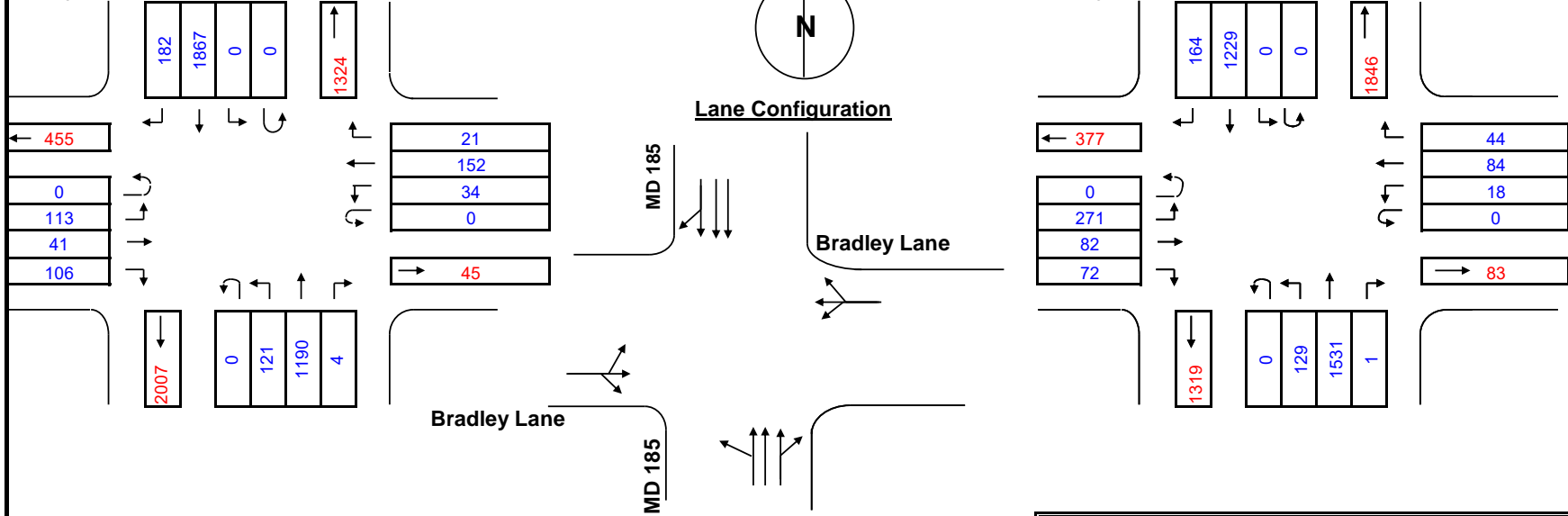

Number of Lanes	Lane Use Factor	Service Level	Critical Lane Vol	Opposing Volume (VPH)	PCE
1	= 1.00	A	<= 1000	<= 199	1.1
2	= 0.53	B	<= 1150	<= 599	2.0
3	= 0.37	C	<= 1300	<= 799	3.0
4	= 0.25	D	<= 1450	<= 999	4.0
Dbl-Lt = 0.60		E	<= 1600	> 1000	5.0
		F	> 1600		

Phasing

RTOR/Overlap
 Northbound
 Southbound
 Eastbound
 Westbound

Split Phasing
 East/West
 North/South
 None

Inx. Control
 Signal
 Stop

Phase	Movement	Volume 1	Lane Use Factor - 2	Lane volume 1 X 2	Opposing Movement	Critical In. volume	*	Phase	Movement	Volume 1	Lane Use Factor - 2	Lane volume 1 X 2	Opposing Movement	Critical In. Volume	*
	NB	1799	0.37	666	0	666			NB	2177	0.37	805	0	805	*
	SB	2049	0.37	758	121	879	*		SB	1393	0.37	515	129	644	
	EB	260	1.00	260	0	260	*		EB	425	1.00	425	0	425	*
	WB	207	1.00	207	0	207	*		WB	146	1.00	146	0	146	*

Remarks: * Critical volume Total **1346** Level of service (V/C) **0.84** **D** Remarks: * Critical volume Total **1376** Level of service (V/C) **0.86** **D**