



**Permit Guidelines for Solar Photovoltaic (PV)  
Systems 2017 NEC Article 690**

*Please note: Building and Electrical permits are required for PV systems. The following information must accompany all building permit applications. Commercial systems must be designed, stamped and sealed by Maryland P.E.*

**1) Basic site plan diagram identifying location of major components—not to scale. This is a simple diagram to show where the equipment is located with the equipment clearly shown and identified on the plan. If PV array is ground-mounted, clearly show that system will be mounted within allowable zoned setbacks. (Two copies)**

**2) Electric diagram showing all major field-installed electrical components, wire identification and sizing, and grounding. This diagram needs to have sufficient detail to call out the electrical components, the wire types and sizes, number of conductors, and conduit type and size where needed. This will typically include detailed module information, series/parallel configuration of modules, details of the Photovoltaic Output Circuit, wire type and size of module wiring, type and size of any junction or combiner boxes, approximate length of conductors in PV array, approximate length of conductors from junction box to the photovoltaic power source disconnecting means. Other important information includes equipment grounding of the PV array and system grounding of the inverter. It will also include specific information on the PV inverter and all associated wire in and out of the inverter. The utility disconnect type and location and the means of connection to the building electrical system should be clearly identified. (Two copies) *Sample diagrams on pages 6-9.***

**3) Major component information:**

*a) Inverter information:*

I. Model number and manufacturer’s “cut sheets” for the specific model.

II. Listing. Is the inverter listed by a Nationally Recognized Testing Laboratory (NRTL) such as UL 1741 and labeled “Utility-Interactive”? If the utility interactive labeling is not provided, does the device comply with the requirements of IEEE Std. 929-2000 (ANSI) as verified by the instruction manual and validated by the listing agency. The 2017 NEC [690.5 (C)] now requires labeling;

**WARNING  
ELECTRICAL SHOCK HAZARD  
IF A GROUND FAULT IS INDICATED  
NORMALLY GROUNDED CONDUCTORS  
MAY BE UNGROUNDED AND ENERGIZED**

*This label is to appear on the inverter or near the ground fault indicator at a visible location*

III. Maximum continuous output power at 40°C

IV. DC input voltage range

V. AC output voltage range

b) *Module information:*

- I. Manufacturer's "cut sheets" for the specific model.
- II. Listing. The module(s) should be listed to UL 1703.  
**Explanation: All electrical devices and components must be listed to UL® (Underwriters Laboratories) North American Standards**
- III. Open-circuit voltage. Note: When open-circuit voltage temperature coefficients are supplied in the instructions for listed PV modules, they shall be used to calculate the maximum PV system voltage as required by [110.3(B)] instead of using Table [690.7]
- IV. Maximum permissible system voltage. [690.7(A-E)]
- V. Short-circuit current rating.
- VI. Maximum series fuse rating.
- VII. Maximum power at Standard Test Conditions.
- VIII. Operating voltage.
- IX. Operating current.

*Alternating-Current Photovoltaic Modules:*

Alternating-current modules shall be marked with identification of terminals or leads and with identification of the following ratings:

- I. Nominal operating ac voltage.
- II. Nominal operating ac frequency.
- III. Maximum ac power.
- IV. Maximum ac current.
- V. Maximum overcurrent device rating for ac module protection.

c) *Battery information (if used):*

- I. Manufacturer's "cut sheets" for the specific model. Note storage and venting requirements.
- II. Nominal battery voltage for the system.

**4) Array information:**

- a) *Number of modules in series, number of parallel source circuits, and total number of modules.*
- b) *Operating voltage (sum of series modules operating voltage in source circuit).*
- c) *Operating current (sum of parallel source circuit operating currents). [690.8]*

d) *Maximum system voltage.* [690.7]

e) *Short-circuit current rating.* [110.10]

## 5) Wiring and Overcurrent Protection:

### a) *Wire Type:*

PV module interconnections should be 90° C wet-rated conductors.

Allowable wire types are as follows:

USE-2 single conductor cable for exposed applications and single conductor cable listed and labeled for PV use. Type TC multiconductor cable for exposed applications with THWN-2 or XHHW-2 or RHW-2 or equivalent 90° C wet-rated conductors in the cable. Type THWN-2 or XHHW-2 or RHW-2 or equivalent 90° C wet-rated conductors in high temperature conduit (conduit rated for a minimum of 75° C wet conditions).

### b) *Conductor Ampacity:*

Correct maximum current and ampacity calculations should be provided for each circuit. (Ampacity of conductors must be sufficient for application) [690.8]

I. The maximum PV source circuit current is the sum of parallel module rated short circuit currents multiplied by 125 percent [690.8(A)(1)].

II. The minimum source circuit conductor ampacity is 125 percent of the maximum PV source circuit current [690.8(B)(1)].

III. Minimum photovoltaic output circuit conductor ampacity is the sum of the maximum current of the parallel source circuits X1.25 [690.8(B)(1)]. Calculating ampacity of conductors used for the PV output circuit can be an involved process.

IV. Minimum inverter output circuit conductor ampacity must be equal to or greater than the inverter continuous output current rating times 1.25. [690.8 (A)]

Informational note: *Where the requirements of [690.8(A)(1)&(B)(1)] are both applied, the resulting multiplication factor is 156%.*

### c) *Overcurrent protection:* Necessary fuses or circuit breakers must be properly sized and specified for each circuit.

- I. PV source circuit, PV output circuit, inverter output circuit, overcurrent protection must be sized so that both the PV module and the conductor from the module to the overcurrent device are properly protected [690.9 (A), 240.15 (A)]. PV modules must be protected so that the maximum series fuse rating, printed on the listing label, is not exceeded. The module may be protected either by installing fuses or circuit breakers in a series string of modules or by the design of the PV system. Inverters listed with a Maximum utility back feed current that is well above 1 amp (typically equal to the maximum allowable output overcurrent protection) must be assumed to provide back feed current to the PV array. Each source circuit must have overcurrent protection that is greater than or equal to the minimum PV Source Circuit current rating and less than or equal to the maximum series fuse rating.

For an inverter listed with a Maximum utility back feed current that is zero, two source circuits can be connected to the inverter without requiring overcurrent protection on either circuit. [690.9 (A) exceptions (a)&(b)]

II. Storage Battery (if used) [690.71 A & B] Installation, [690.71 (H)] Disconnect and over current protection.

III. For requirements of Point of Connection of a *utility interactive* PV inverter to the building electrical system see [705.12].

## 6) Rapid shutdown of PV systems on Buildings

PV system circuits installed on or in buildings shall include a rapid shutdown function that controls specific conductors in accordance with [690.12 (1) through (5)]

## 7) Provisions for the photovoltaic power source disconnecting means

The 2017 NEC states in [690.13 A through E], “*Location. The photovoltaic disconnecting means shall be installed at a readily accessible location either outside of a building or structure or inside nearest the point of entrance of the system conductors...The photovoltaic system disconnecting means shall not be installed in bathrooms.*”

I. Readily accessible—[Article 100] states, “*Accessible, Readily (Readily Accessible). Capable of being reached quickly for operation, renewal, or inspections without requiring those to whom ready access is requisite to climb over or remove obstacles or to resort to portable ladders, and so forth.*”

II. A rooftop disconnect on a residential roof will normally not qualify as a readily accessible disconnect.

## 8) Grounding:

The NEC [690.41] requires all systems operating above 50 volts have one conductor referenced to ground unless the system complies with the requirements of [690.35 (A-G)] for ungrounded PV arrays. **All devices and components of grounding/bonding system must be listed for use.**

a) *Equipment grounding conductor sizing.* [690.45] The size of the equipment grounding conductor is dependent on whether the system has ground fault protection (GFP) equipment or not. The provisions for GFP equipment are stated in [690.5]. Many residential inverters have GFP equipment integral to the inverter and require that the PV array be grounded at the inverter only.

I. Systems with ground fault protection equipment. Size equipment grounding conductor according to NEC [Table 250.122].

II. DC System: Size grounding electrode conductor according to NEC [250.166].

## 9) Array Mounting information: **You will need this information to obtain your building permit**

- I. Provide two copies of the site plan showing the location of the house and PV equipment.
- II. Provide two copies of the array layout and the supporting structure. ***If roof mounted;*** show anchorage to the roof and framing structure and schematic elevations. Identify methods of sealing all roof penetrations. ***If ground or pole mounted;*** show array supports, connection details, framing members, and foundation posts and footings. In either case the plans showing the supporting structure details must be signed and

sealed by a Maryland Licensed Professional Engineer certifying the design is in accordance with the applicable codes in Montgomery County, MD.

#### 10) Additional Ground Mounted Solar Panel Installation Requirements

For ground mounted Residential Solar Panels, the following will apply:

**Clearances.** A clearance of 10 feet around the ground-mounted photovoltaic installations shall be provided. (This does not mean the skirt or fence must be 10 feet away)

**Noncombustible Base.** A gravel base with a 4-mil poly, or weed screen under the gravel, or other non-combustible base acceptable to the AHJ shall be installed and maintained under and around the installation. (Other approved base material would be Concrete, or Asphalt)

**Security Barriers.** Fencing, or flame-retardant skirting around the entire array. (Fence must be at least 4 feet in height, not easily climbable, (to keep unqualified persons out), gates must swing out away from the array.

For zoning purposes, Ground Mounted Solar Panels must meet the required setbacks for an accessory structure for the Zone they are located in, and cannot produce more than 120% of the current being consumed onsite.

#### 11) Removal of Solar Panels from a Residential Roof

An **ALTERATION** Building Permit, and an Electrical permit will be required for the removal of solar panels from a Residential roof. The alteration plans must show how the roof penetrations will be repaired and must include **ELECTRICAL** drawings showing how the electrical connections will be capped off or removed. For taps ahead of the main in the electrical panel; a new service entrance cable from the panel to the meter will be required.

#### 12) Inspections:

*a) Building permit.*

- I. Footing, inspection code 001. (If applicable)
- II. Framing, inspection code 004. (If applicable)
- III. Final, inspection code 251.

*b) Electrical permit.*

- I. Concealment, inspection code 104 (For wiring in walls, ceilings and trenches).
- II. Final, inspection code 251. Installer shall provide to the DPS inspector photos depicting the array support connections, module (PV panel) data plates, all electrical connectors, all ground connections, all conductor supports, and all sealed roof penetrations for all components that are not "readily accessible" (requiring ladder access), the 'Residential Photovoltaic Systems Installation Certification' and the 'PV Field Inspection Checklist' – COMPLETED BY INSTALLER

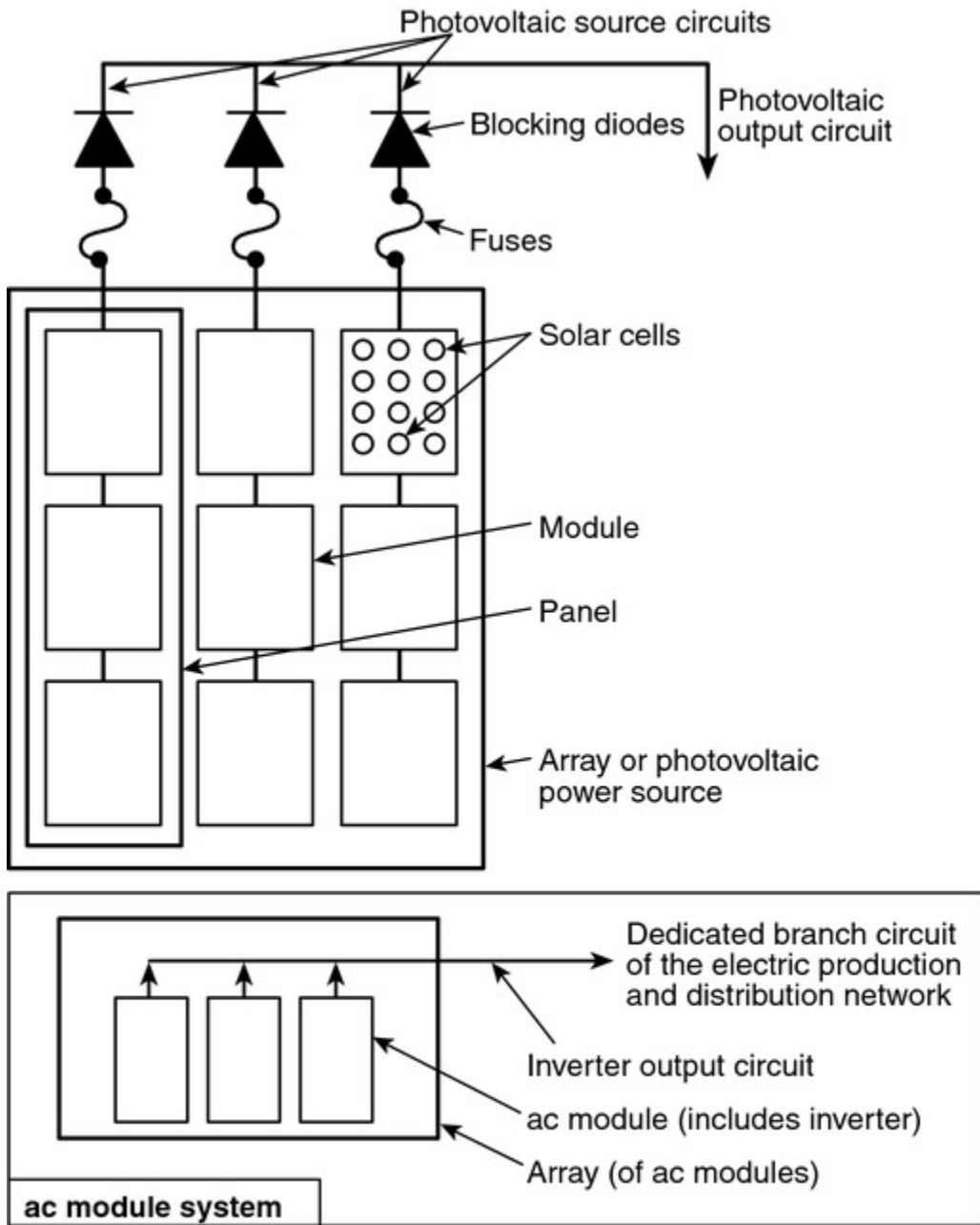

**Notes:**

1. These diagrams are intended to be a means of identification for photovoltaic system components, circuits, and connections.
2. Disconnecting means required by Article 690, Part III, are not shown.
3. System grounding and equipment grounding are not shown. See Article 690, Part V.

Figure 690.1(a) Identification of Solar Photovoltaic System Components.

**Sample of Electrical Diagram (From NEC)**

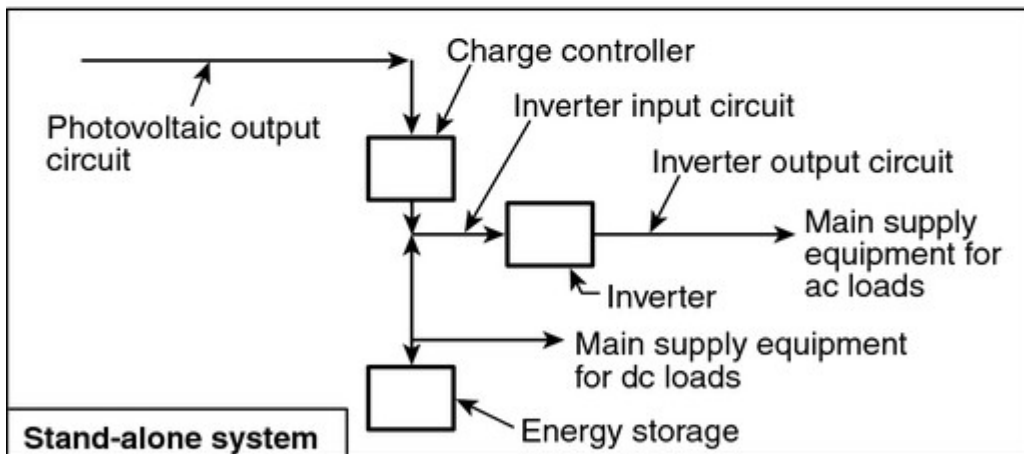
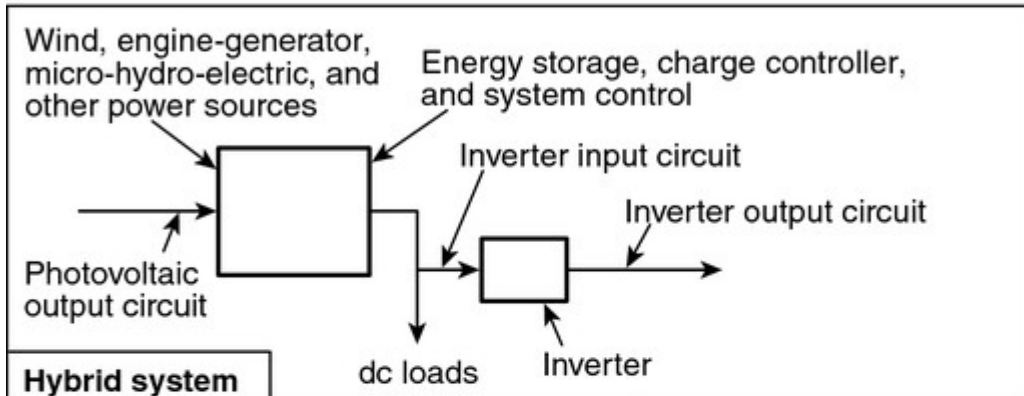
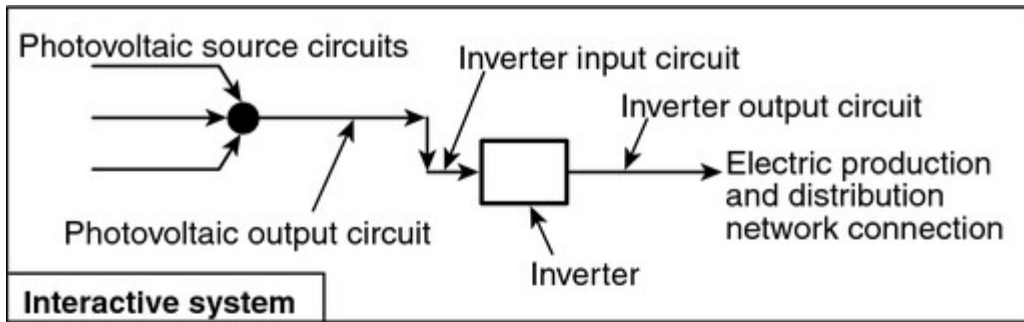

Notes:

1. These diagrams are intended to be a means of identification for photovoltaic system components, circuits, and connections.
2. Disconnecting means and overcurrent protection required by Article 690 are not shown.
3. System grounding and equipment grounding are not shown. See Article 690, Part V.
4. Custom designs occur in each configuration, and some components are optional.

Figure 690.1(b) Identification of Solar Photovoltaic System Components in Common System Configuration.

**Sample of Electrical Diagram (From NEC)**

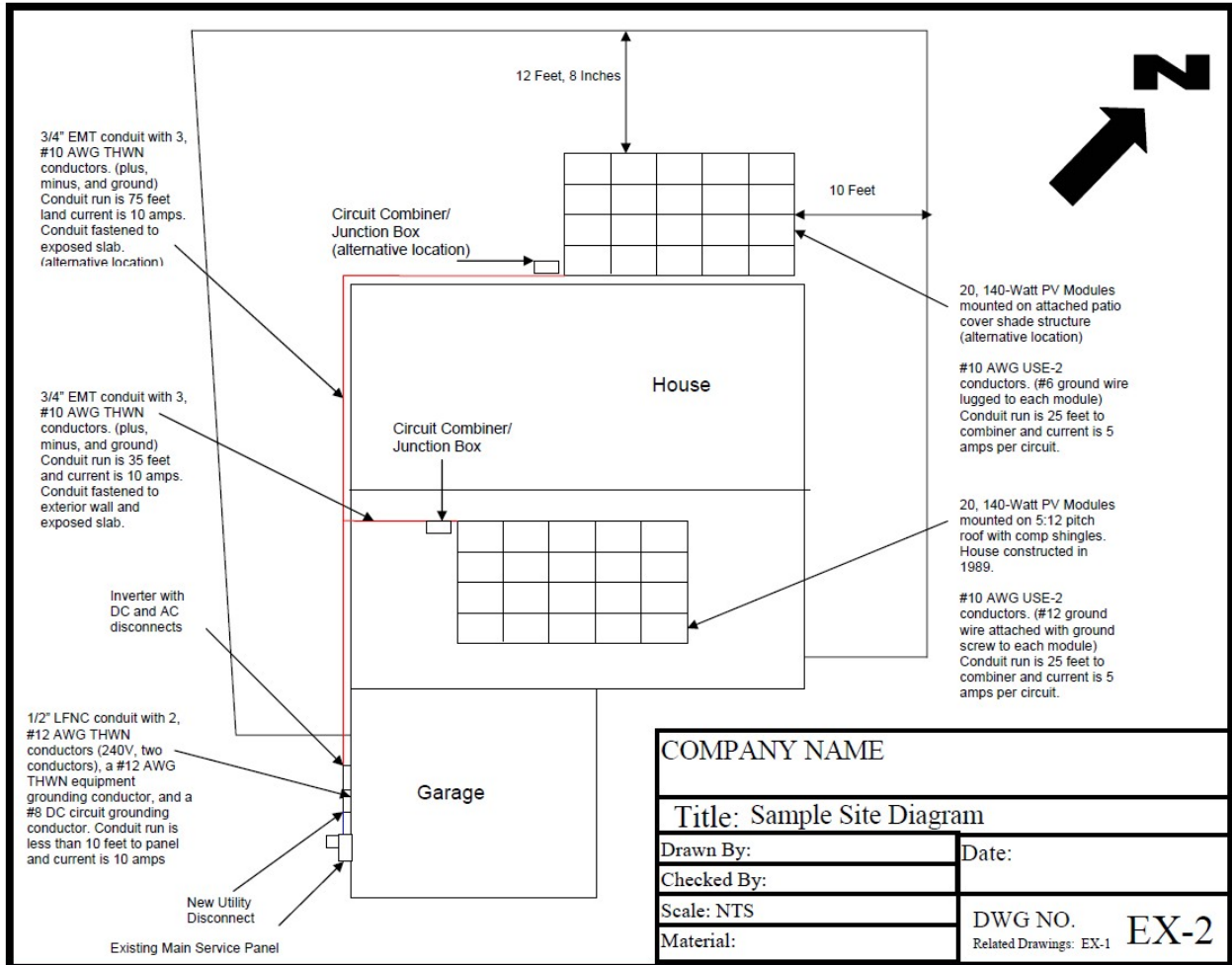

## Sample of Site Plan



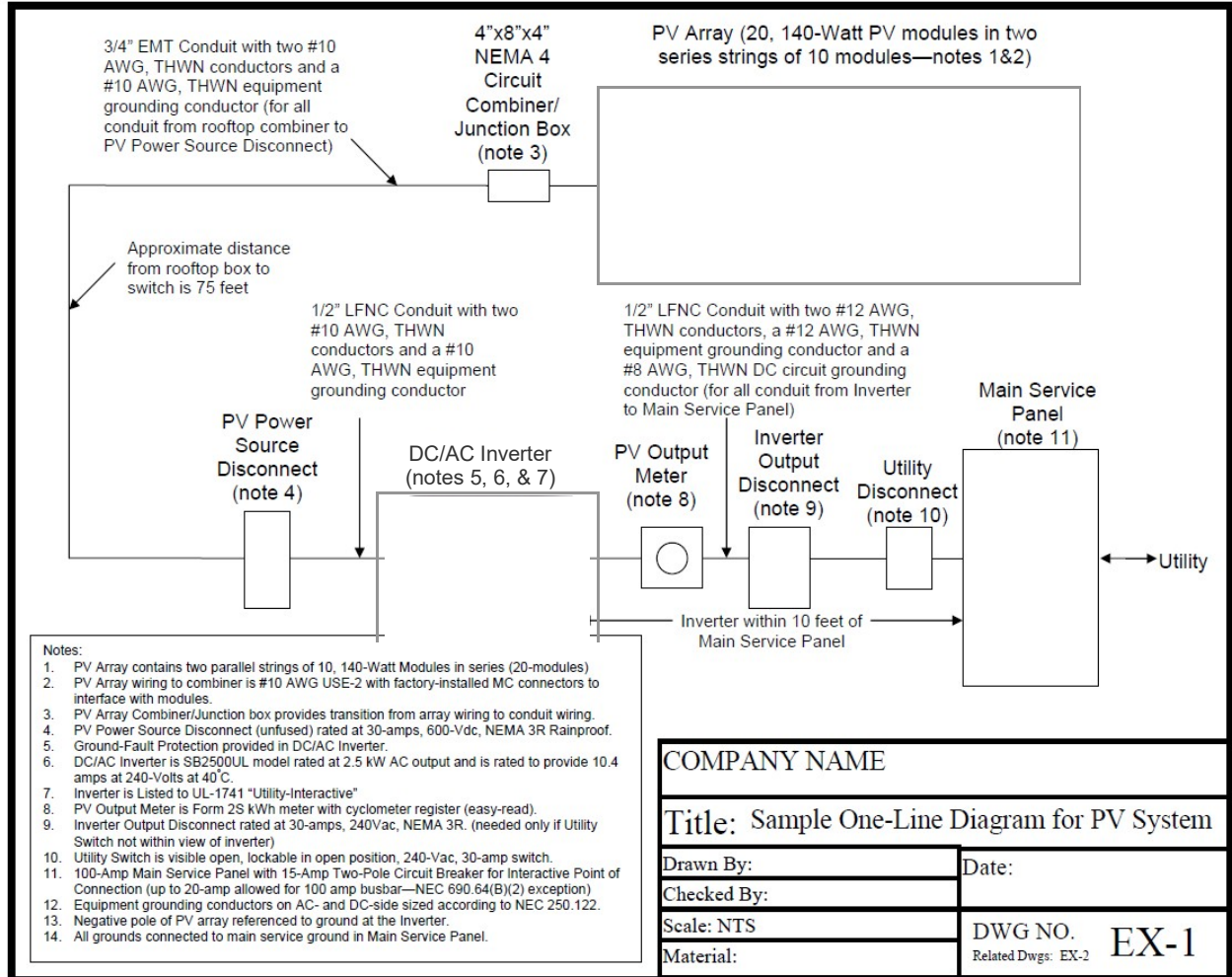

Sample of One-Line Diagram

## PV Quick Design and Installation Reference/NEC 2014.

**Qualified Personnel [690.4 (C), 100] The installation of equipment and all associated wiring and interconnections shall be performed only by qualified persons. *INFORMATIONAL NOTE:* See Article 100 for definition of *qualified person*.**

Use Open Circuit Voltage as the Rated Voltage in the PV Source Circuit [690.7 (A)]

Voltages shall be  $\leq$  600 Volts [690.7 (C)]

Live parts in Source and PV output circuits over 150 volts to ground shall not be accessible to other than qualified persons while energized. [690.7 (D)]

Ampacity and overcurrent device ratings in PV systems shall be considered continuous. [690.8 (B)]

Conductors and overcurrent devices shall be able to carry  $\geq$  125% of the short-circuit current of the source circuit [690.8 (B)(1)]

PV source circuit, inverter and battery conductors shall have overcurrent protection [690.9 (A) & (B)]

Grounded conductor to be white in color. [200.6]

A means to disconnect and isolate all source circuits shall be provided. [690.13]

All ungrounded conductors shall be able to be disconnected from the inverter and all other equipment. [690.15]

If fuses are used, you must be able to disconnect the power from both ends (isolate). [690.16]

Disconnects shall be accessible and clearly labeled. [690.17]

Single conductor cable is permitted for module connections only; cable exposed to sunlight must be sunlight resistant. [690.31 (C) (1)]

Connectors shall be polarized and guarded to prevent shock. [690.33]

Any wiring junction boxes shall be accessible. [690.34]

Marking: all modules shall be marked indicating the system operating voltage and current, the open circuit voltage, and the short circuit current, etc., shall be placed near the system disconnect point or as specified. [690.51, 690.52, 690.53]

All required labels shall comply with Articles [690.5 (C), 690.7 (E), 690.10 (C), 690.17(E), 690.31 (G) (3) (4), 690.35 (F), 690.56 (A) (B) (C)]

**Photovoltaic Field Inspection Checklist: To be completed by installer.**  
**Provide to DPS inspector at the final inspection**

Electrical permit # \_\_\_\_\_

Building permit # \_\_\_\_\_

Premises address: \_\_\_\_\_

Date of inspection by installer: \_\_\_\_\_

Installed and inspected by: \_\_\_\_\_ Print name: \_\_\_\_\_

	Yes	No	Comments
Are the installation photos on site			
Are permit documents and plans on site			
Do the PV module model numbers match plans and cut-sheets			
Are the modules properly grounded per cut-sheets			
Does the array layout and associated wiring match plans			
Are cables and conduits properly supported			
Are all plug connectors used in the array fully engaged			
Does the inverter model number(s) match plans and cut-sheets			
Does the array support structure match plans			
If roof mounted, are all roof penetrations properly sealed			
If ground mounted, have the footings and structure been approved			
Are the required signs/labels durable enough for the environment			
Shock hazard warning label installed [690.5(C)]			
Shock hazard warning label, <i>ungrounded DC conductors</i> [690.35(F)]			
Marking identifying PV (DC) power source including the following: [690.53]			
Operating current (on plans)			
Operating voltage (on plans)			
Maximum system voltage [690.7]			
Short circuit current [690.8]			
Marking identifying AC point of connection including the following: [690.54]			
Maximum operating current (on plans)			
Operating AC voltage (on plans)			
Marking identifying disconnecting means for PV system [690.13(B)]			
Sign at main service disconnect for remote location of PV disconnect [690.56]			
Sign for buildings/structures w/both utility & PV systems, for Rapid Shutdown [690.56(C)]			
Warning label for disconnect of <i>ungrounded conductors</i> [690.17(E)]			
Sign for optional stand-by system [702.8]			
Signed Residential Photovoltaic Systems Installation Certification			
Carbon Monoxide detectors installed per IRC Section R315			
Installation meets the standards and requirements of the Montgomery County Fire Code			
Installation complies with plumbing and gas vents per WSSC Plumbing Code Section 106.1			

Received by DPS: \_\_\_\_\_ Date: \_\_\_\_\_



**DPS**

Montgomery County  
Department of Permitting Services



2425 Reddie Drive, 7th Floor  
Wheaton, MD 20902  
240-777-0311  
montgomerycountymd.gov/dps

## Residential Photovoltaic Systems Installation Certification

**To be completed by the Installer.**

This certification report is submitted in conformance with procedures established by the Department of Permitting Services (DPS).

I certify this is a true report of jobsite conditions: all structural/mechanical attachments to the structure(s) are in conformance with the approved engineered plans and, that the Laws and Building Codes of Montgomery County are being followed.

Permit # \_\_\_\_\_

Date installation completed: \_\_\_\_\_

Address: \_\_\_\_\_

Photos included:  Yes  No

Inspection Checklist included:  Yes  No

*Note: Final inspection approval will not be given without photos of the installation and the inspection checklist.*

Name of Company/Installer: \_\_\_\_\_ Phone: \_\_\_\_\_

Signature: \_\_\_\_\_ Printed name: \_\_\_\_\_ Date: \_\_\_\_\_

## Photovoltaic Field Inspection Checklist: To be completed by installer.

*Provide to DPS inspector at the final inspection.*

Electrical permit # XXXXXX

Building permit # XXXXXX

Premises address: \_\_\_\_\_

Date of inspection by installer: \_\_\_\_\_

Installation inspected by: \_\_\_\_\_ Print name: \_\_\_\_\_

	Yes	No	Comments
Are the installation photos on site	X		
Are permit documents and plans on site	X		
Do the PV module model numbers match plans and cut-sheets	X		
Are the modules properly grounded per cut-sheets	X		
Does the array layout and associated wiring match plans	X		
Are cables and conduits properly supported	X		
Are all plug connectors used in the array fully engaged	X		
Does the inverter model number(s) match plans and cut-sheets	X		
Does the array support structure match plans	X		
If roof mounted, are all roof penetrations properly sealed	X		
If ground mounted, have the footings and structure been approved			Not applicable
Are the required signs/labels durable enough for the environment	X		
Shock hazard warning label installed [690.5(C)]	X		
Shock hazard warning label, <i>ungrounded DC conductors</i> [690.35(F)]	X		
Sign identifying PV (DC) power source including the following: [690.53]	X		
Operating current (on plans)	X		
Operating voltage (on plans)	X		
Maximum system voltage [690.7]	X		
Short circuit current [690.8]	X		
Sign identifying AC point of connection including the following: [690.54]	X		
Maximum operating current (on plans)	X		
Operating AC voltage (on plans)	X		
Sign identifying disconnecting means for PV system [690.14]	X		
Sign at main service disconnect noting remote location of PV disconnect [690.56]	X		
Warning label for disconnect of <i>ungrounded conductors</i> [690.17]	X		
Sign for optional stand-by system [702.8]			Not applicable
Signed Residential Photovoltaic Systems Installation Certification	X		
Carbon Monoxide detectors installed per IRC Section R315	X		
Installation meets the standards and requirements of the Montgomery County Fire Code	X		
Installation complies with plumbing and gas vents per WSSC Plumbing Code Section 106.1	X		

Received by DPS: \_\_\_\_\_ Date: \_\_\_\_\_



**DPS** | Montgomery County  
Department of Permitting Services



2425 Reddie Drive, 7th Floor  
Wheaton, MD 20902  
240-777-0311  
montgomerycountymd.gov/dps

## Residential Photovoltaic Systems Installation Certification

**To be completed by the Installer.**

This certification report is submitted in conformance with procedures established by the Department of Permitting Services (DPS).

I certify this is a true report of jobsite conditions: all structural/mechanical attachments to the structure(s) are in conformance with the approved engineered plans and, that the Laws and Building Codes of Montgomery County are being followed.

Permit # XXXXXXX

Date installation completed: XX/XX/XXXX

Address: XXXXXXXXXXXXXXXXXXXXXXXXXXXX

Photos included:  Yes  No

Inspection Checklist included:  Yes  No

*Note: Final inspection approval will not be given without photos of the installation and, the Inspection Checklist.*

Name of Company/Installer: \_\_\_\_\_ Phone: \_\_\_\_\_

Signature: \_\_\_\_\_ Printed name: \_\_\_\_\_ Date: \_\_\_\_\_

[Solar Company Letterhead]

Property Owners Name: \_\_\_\_\_

Property Owners Address: \_\_\_\_\_

Address of installation if different than owners address:

\_\_\_\_\_

I certify that:

I prepared or approved the electrical drawings and related documents for the photovoltaic (PV) system at the above location.

The design of the PV system, and all electrical installations and equipment, meets the standards and requirements of the National Electrical Code as adopted by Montgomery County in COMCOR 17.02.01.

\_\_\_\_\_  
Maryland PE License Number

Date \_\_\_\_\_

Seal

Signature \_\_\_\_\_

-----

\_\_\_\_\_  
Montgomery County Master Electrician License Number

Date \_\_\_\_\_

Signature \_\_\_\_\_

**Must Be Submitted with Plans**

[Company Letterhead]

Project \_\_\_\_\_ Property Owner \_\_\_\_\_

Address \_\_\_\_\_

- I reviewed the design of the photovoltaic (PV) system, as designed by the manufacturer, and the design criteria utilized for the mounting equipment and panel mounting assembly (rack system) for the installation of \_\_\_ (#) panels supported by the rack system, as shown on the drawings prepared for the above referenced address. I certify that the configurations and design criteria meet the standards and requirements of the International Residential Code (IRC) in COMCOR 08.00.02.
- The attachment of the rack system to the building at the above address, including the location, number, and type of attachment points; the number of fasteners per attachment point; and the specific type of fasteners (size, diameter, length, minimum embedment into structural framing, etc.) meets the standards and requirements of the IRC adopted by Montgomery County in COMCOR 08.00.02.
- I evaluated the existing roof structure of the building at the above address and analyzed its capacity to support the additional loads imposed by the PV system. I certify that no structural modifications of the existing roof structure are required. The existing roof structure meets the standards and requirements of the IRC, adopted by Montgomery County in COMCOR 08.00.02, necessary to support the PV system.
- I evaluated the existing roof structure of the building at the above address and analyzed its capacity to support the additional loads imposed by the PV system. Structural modifications of the existing roof structure are required. I certify that the roof structure, as modified on the drawings for this project, will support the additional loads imposed by the PV system. I further certify that design of the modified roof structure meets the standards and requirements of the IRC, adopted by Montgomery County in COMCOR 08.00.02.
- I prepared or approved the construction documents for the mounting equipment, rack system, roof structure for this project.

**Re-installations:**

- I certify that the reinstallation of the photovoltaic system (PV) as shown on the approved drawings for permit \_\_\_\_\_ (show original permit #) does not alter the approval under the permit or make the PV system, attachment to the building, and roof framing unsafe.

\_\_\_\_\_  
Maryland PE License Number

Date \_\_\_\_\_

Seal

Signature \_\_\_\_\_