



# ALCOA



# WHEEL SERVICE MANUAL

HEAVY DUTY TRUCK  
| TRAILER | BUS |  
MOTOR HOME

**IMPORTANT SAFETY PRECAUTIONS FOR TRUCK RIMS AND WHEELS**

JANUARY 2012  
SUPERSEDES APRIL 2011

**IMPORTANT:** Federal OSHA Regulations require all employers to make sure their employees who service rims/wheels understand the safety information contained in this manual. Do not let your employees service rims/wheels unless they are thoroughly trained and completely understand this safety information.

If you are a service technician do not service rims/wheels unless you are thoroughly trained and completely understand this safety information.

# ALCOA LIMITED WARRANTY

FOR HEAVY DUTY TRUCKS, TRUCK TRAILERS,  
BUSES, RV and MOTORHOME WHEELS

This limited warranty applies to Alcoa forged aluminum wheels with bead seat diameters measured in .5 inch increments ("Wheels") and the surface of rim flange treatments applied to the Wheels. "Transit Wheels" means Wheels used on transit vehicles, such as buses and vans, whose primary purpose is to transport people.

Alcoa warrants to the original purchaser, from Alcoa or its authorized distributor, that a new Alcoa truck, truck trailer, bus, RV or motorhome Wheel is free from defects in material and workmanship for the applicable time period set below:

- (a) Except as stated in (b) of this section, Wheels are warranted for 60 months from the date of manufacture as shown on the Wheel.
- (b) Transit Wheels and RV and motorhome Wheels are warranted for 120 months from the date of manufacture as shown on the Wheel.

Alcoa agrees, without charge, to repair or replace a Wheel that fails in normal use (see the qualifications section below) because of defects in material and workmanship.

Alcoa warrants to the original purchaser from Alcoa or its authorized distributor the Dura-Flange® rim flange treatment against sharp edges for 24 months from the date of manufacture as shown on the Wheel. Alcoa warrants to the original purchaser from Alcoa or its authorized distributor the Dura-Bright® surface treatment against (i) filiform corrosion (worm or hair like lines, generally milky in appearance, underneath surface protective treatment and emanating from damage to the surface treatment such as nicks, scratches, or damage from the mounting hardware or wheel weights), (ii) blistering due to loss of adhesion of the surface treatment and (iii) lift off of the surface treatment due to physical damage (nicks, scratches, gouges). The foregoing Dura-Bright® surface treatment warranty is applied for the application period of time set forth below:

- (a) Except as stated in (b) of this section, Dura-Bright® surface treatment on Wheels is warranted for 60 months from the date of manufacture as shown on the Wheel.
- (b) Dura-Bright® surface treatment for RV and motorhome Wheels is warranted for 120 months from the date of manufacture as shown on the Wheel.

If the Dura-Flange® rim flange treatment or Dura-Bright® surface treatment fails in normal use or service (see the qualifications section below) to meet the foregoing warranties on any Wheel, Alcoa agrees, without charge, to replace the Wheel.

**Qualifications:** Alcoa does not warrant, and will not repair or replace or make adjustment, with respect to any Wheel or surface or rim flange treatment on such Wheel that has been subjected to misuse or abuse or any of the following:

- (a) Using a tire which is oversized according to standards recommended by the Tire and Rim Association, Inc. or other recognized tire and rim agencies such as ETRTO (Europe);
- (b) Loading the Wheel beyond the applicable maximum wheel load as specified by Alcoa;
- (c) Inflating tires beyond the applicable maximum as specified by Alcoa;
- (d) Changing the original condition of the Wheel by alteration or by subjecting it to any processing such as welding or straightening.
- (e) Accidents; or abnormal or severe operating conditions including, without limitation, tire fires, brake fires, severe brake system drags or seizures or running with a flat tire;
- (f) Failure to follow maintenance instructions or warnings set forth in the Alcoa Wheel Service Manual ("Service Manual"), Alcoa Technical Bulletins or other Alcoa literature. Recommended maintenance includes, without limitation, using proper torque, periodic cleaning, polishing, valve replacement, periodic inspection for damage, and loose lug nuts and rim flange wear inspections and procedures.
- (g) Nicks, scratches and other surface blemishes resulting from improper maintenance, cleaning, road debris, curbing, accident.
- (h) Rim flange wear (unless the rim has been treated with Dura-Flange®); or
- (i) Damage due to cleaning with abrasives, abrasive brushes, steel wool, scouring pads, or strong chemicals (acids or alkaline).

Alcoa's liability and purchasers' exclusive remedy for a Wheel or surface or rim treatment on such Wheel that does not comply with the foregoing warranties is limited to repair or replacement of the Wheel.

Alcoa shall not be liable for any incidental, consequential, indirect or special damages for any breach of warranty. There is no warranty that a Wheel or surface or rim treatment of such Wheel shall be merchantable or fit for any particular purpose. Nor is there any other warranty, express or implied, except such as is expressly set forth in this limited warranty.

This limited warranty should be used in conjunction with the Service Manual and the Alcoa Dura-Bright® Wheel Finish Care and Maintenance manual. The Service Manual contains important safety information and warnings, and failure to read and understand this information may result in serious injury or death.



**WARNING** Wheels that are not properly installed or maintained may not be safe.

Failure to follow proper wheel installation or maintenance practices may result in injury or death.

Follow the proper wheel installation and maintenance practices as contained in this Alcoa Service Manual. For additional copies of the manual and other useful items listed below, available free of charge, or for the most recent updates, contact Alcoa Wheel and Transportation Products at 1-800-242-9898 or on the web at [www.alcoawheels.com](http://www.alcoawheels.com).

To obtain information on free training on proper installation and maintenance procedures, contact Alcoa Wheel Products at (800) 242-9898 or on the web at [www.alcoawheels.com](http://www.alcoawheels.com).

## Important information available free from Alcoa:

- Alcoa Wheel Service Manuals
- Disc Wheel Service Manual

## Videos/CD

- Safe Wheel and Tire Changing Practices for Heavy Duty Trucks and Buses
- Maintaining Your Edge Rim Flange Maintenance
- Simple Facts about Hub-Piloted Wheel System Maintenance
- Disc Wheel Inspection CD published by the TIA

## Maintenance Charts

- Zipper Rupture  
Published by RMA
- Tire Information Service Bulletin  
Published by RMA
- Heavy & Medium Truck & Trailer Torque Specifications  
Published by WRIS
- Demounting & Mounting Procedures for Truck/Bus Tires  
Published by RMA
- Multipiece Rim Matching Chart  
Published by OSHA
- Mounting/Demounting Instructions for Alcoa Aluminum 19.5" RW  
Published by Alcoa Wheel and Transportation Products
- Wheels and Steel Disc 19.5" Wheels  
Published by Alcoa Wheel and Transportation Products

## Alcoa Rim Flange Safety Material

- Maintaining Alcoa Aluminum Wheels Rim Flange Wear Instructions
- Rim Flange Wear Gauge

Technical Bulletins available at [www.alcoawheels.com](http://www.alcoawheels.com).

- Welding Rim Flange or otherwise heating Alcoa Aluminum Wheels
- Altering Alcoa Wheels from original design and use of adaptor plates
- Tire Balancers/Sealants
- Wheel balancing weights
- Mounting/demounting tires on Alcoa 22.5 non-symmetrical wide base wheels
- Rim Flange Wear

# Table of Contents

## How to use this manual

This manual is written in a style called structured text.

Throughout the manual you will find numbers which look like this (See Section 3-1). These numbers are cross references to other sections of the manual. The numbers (3-1) refer to section 3, subtopic 1. You will find the section number and subtopic number under the heading in each section.

□ Section Number	Page Number □
1 Safety .....	2
2 Inspection and Maintenance .....	3
2-1 Inspect thoroughly and frequently .....	3
2-2 Wheel alteration .....	3
2-3 Heat damage .....	4
2-4 Dimension checks .....	5
2-5 Cracked or damaged wheel checks .....	6
2-6 Mounting area .....	7
2-7 Corrosion .....	8
2-8 Bolt holes .....	9
2-9 Disc area .....	9
2-10 Rim area .....	10
2-11 Bead Seat area .....	10
2-12 Rim flange wear .....	11
2-13 Dura-Flange <sup>®</sup> maintenance .....	16
2-14 Maintenance against corrosion (non Dura-Bright <sup>®</sup> surface treated wheels) .....	16
2-15 Dura-Bright <sup>®</sup> surface treated wheels cleaning and maintenance .....	16
3 Mounting Alcoa Wheels with Tubeless Tires .....	17
3-1 Recommendations for mounting tubeless tires .....	17
3-2 Mounting tubeless tires .....	18
3-3 Mounting tires on non-symmetrical drop well wheels .....	19
3-4 Rim width to tire matching .....	20
3-5 Recommendations for demounting tubeless tires .....	20
3-6 Demounting of tubeless tires .....	21
4 Wheel Installation .....	22
4-1 Recommendations for proper installation of wheels .....	22
4-2 Wheel cap nuts .....	23
4-3 How to measure stud standout .....	24
4-4 Stud located ball seats are spherical .....	24
4-5 Stud-Piloted Mounting System (Single and wide base wheel, stud located, ball seat mounting) .....	24
4-6 Dualled wheels, stud located, ball seat mounting .....	25
4-7 Dualled wheels, steel inner/aluminum outer stud located, ball seat mounting .....	27
4-8 Tightening stud located, ball seat cap nuts .....	28
4-9 Hub-Piloted Mounting System (Single, dualled and wide base wheels, hub piloted mounting, two-piece flange nuts) .....	30
4-10 Tightening hub piloted mounting, two-piece flange nuts .....	31
4-11 Incorrect assemblies .....	33
5 Proper Torque, Wheel Identification and Valves .....	34
5-1 Avoid abuse .....	34
5-2 Keep wheel nuts tight .....	34
5-3 Balance weights .....	35
5-4 Owner/in-service identification .....	35
5-5 Valves .....	35
5-6 Identification .....	36
6 OSHA Regulations .....	37
6-1 OSHA Regulations .....	37
7 Glossary of Common Terms .....	42
7-1 Glossary of Common Terms .....	42
7-2 Wheel measurement .....	44
8 Conversion Tables .....	45
8-1 Inch Fraction, Decimal and Millimeter Equivalents Chart (Up to 1 Inch) .....	45
8-2 Conversion Factors .....	46

1

2

3

4

5

6

7

8

# 1 Safety

Safe service practices are a matter of life and death.



**WARNING** An inflated wheel and tire assembly contains enough air pressure to cause an explosive separation.

Unsafe handling or failure to follow approved mounting and demounting procedures can lead to serious injury or death.

Study, understand and follow the procedures contained in this manual.

Safety is serious business. All tire shops must know and follow OSHA work regulations... no matter how small the shop. Under U.S. federal law any individual handling tire/wheel assemblies must be trained in OSHA regulations as mentioned in section 6.

Safety is everybody's business. Do not attempt to service any wheel assembly without proper training.

Proper equipment is important. Be sure you have the recommended tools and equipment on hand and use them according to manufacturer's instructions.

Tubeless wheels and tires require equal care. Even though tubeless assemblies have fewer parts than multi-piece wheels, they still require respect and proper handling.

Pay particular attention during crucial steps:

- Removal of tire and wheel assemblies from vehicles
- Demounting tire from wheel
- Wheel inspections
- Inflation of tire
- Handling and storing of inflated assembly

Safety and service information is readily available. Wheel, tire and service equipment manufacturers offer service manuals and other training materials. Stay up to date on proper procedures and keep current instructional materials handy in the shop. Study safety and service information and use it on the job.

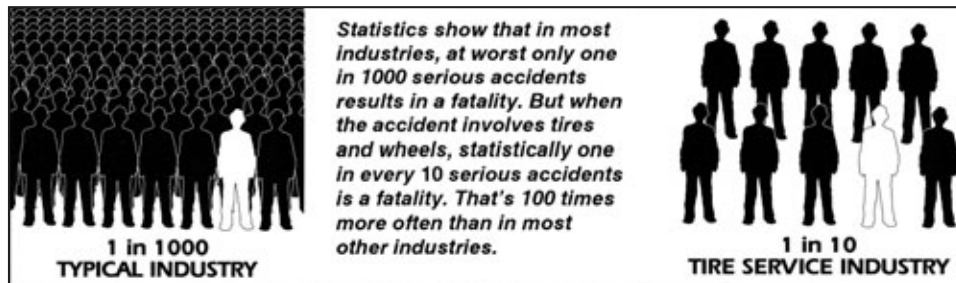

# 2

## Inspection and Maintenance

### Inspect thoroughly and frequently

#### 2-1

Safe operation requires thorough examination of wheels and attaching hardware, at frequent intervals, both on and off the vehicle.

Wheels that have been in service need to be inspected at regular intervals to assure proper and safe performance.

It is not always possible to predict the useful life of a wheel. Wheels will eventually wear out. But generally, older wheels and wheels operating in extreme conditions should be examined more frequently for obvious signs that they should be removed from service.

Examine all exposed areas frequently. Clean wheels and look for cracks, corrosion, wear or other damage. Also check the inner dual wheel when the outer wheel is removed.

During tire changes, thoroughly examine the entire wheel. Pay particular attention to the rim contour and the surfaces of the rim.

#### Hidden Damage

Do not exceed maximum wheel load. Customer must compare OEM vehicle load rating to maximum wheel load rating and inflation pressure which is roll-stamped onto wheel per Section 5-6.

Do not overinflate. Use the tire manufacturer's recommended pressure, but under no circumstances exceed cold tire pressures as listed in Alcoa Wheels Product Spec Guide. Before mounting the tire, perform a wheel fitment check to insure proper clearance from any obstructions.

Some forms of wheel damage can be hidden beneath the tire, so whenever a tire is removed, thoroughly examine the complete wheel. Remove all grease and road dirt. Use a wire brush or steel wool to remove rubber from the bead seats.

Check mounting holes for enlargement and elongation which can occur if the cap nuts are not kept tight (see Section 2-8). Dirt streaks radiating from stud holes may indicate loose cap nuts.

### Wheel alteration

#### 2-2

Alcoa does not approve any form of alteration to wheels except minor cosmetic buffing for appearance purposes or sanding in the rim flange area (see Section 2-12).

Wheels should not be altered by welding, brazing or other heat application in an attempt to repair or straighten a wheel. Use of adapter plates or bead-locks is not approved on Alcoa wheels.

Wheels should not be painted or otherwise coated in any way that may interfere with the mounting surfaces.

Any wheels that show signs of alteration should be removed from service and scrapped.

Wheel identification must be legible. Wheels should be taken out of service if such identification does not meet federal requirements.



**WARNING**

**WARNING** Welding, brazing or otherwise heating any area of an Alcoa aluminum wheel will weaken the wheel. Weakened or damaged wheels can lead to an explosive separation of tires and wheels or wheel failure on the vehicle.

Explosive separations of tires and wheels or wheel failure on the vehicle could cause serious injuries or death.

Never attempt to weld, braze or heat any surface of an Alcoa aluminum wheel.

# Heat damage

2-3



**WARNING** Excessive heat from fire, brake malfunction, wheel bearing failure, tire failure or other sources may weaken the metal and cause the wheel/tire assembly to separate explosively.

Exploding wheel/tire assembly can cause serious injury or death.

Immediately and permanently remove from service any wheel that has been exposed to excessive heat.

Inspect for exposure to excessive heat. A wheel that has been subjected to excessive heat may appear charred or burned. A wheel that has been exposed to excessive heat may appear to be in good condition if it has been cleaned. Do not use any wheel that has been overheated regardless of appearance. Even if a wheel does not appear to be obviously burned, inspect the labels, tire bead, brake drum and high temperature nylon spacer for evidence of charring, melting, blistering or burning.

A wheel may discolor from excessive heat. It can appear a dull grayish color and will not polish to a bright finish as a typical wheel would.

Any wheel run with a flat tire longer than the time necessary to immediately pull off the road should be checked for excessive heat damage.



Charred Sticker (prior to 2009)

After January 2009 the new Alcoa Logo may not show heat damage.

A blistered, charred, blackened or cracked-looking logo decal on an Alcoa wheel may indicate that the wheel has been exposed to excessive heat as shown in picture to the left, or discoloration as shown in picture to the right

Inspect all axle end components for signs of exposure to excessive heat. Pay particular attention to brake drums (or discs), high temperature nylon spacer wheel liners and tire beads. If these components show signs of overheating, the entire assembly, including the wheel, should be replaced.



Discoloration of Wheel



Charred High Temperature Nylon Spacer



Charred Heat Indicator Drop Center (2009 and after)



Charred Rubber



Charred Heat Indicator (2009 and after)

Wheels manufactured starting in January 2009 will have a 1 inch clear round heat indicator located next to the roll stamp on the inside shown on the left and right, along with the same 1 inch clear round heat indicator located on the tire side drop well as shown in the photo above.

If either of these round labels show signs of blistering, or have a charred, blackened, or cracked look, this may indicate that wheel has been exposed to excessive heat.

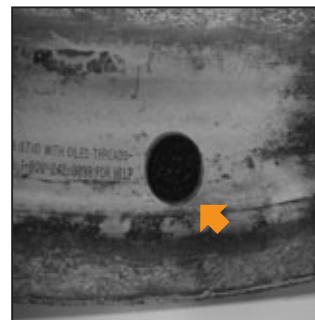

Charred Heat Indicator (2009 and after)

**IF ANY OF THE ABOVE CONDITIONS ARE SEEN, REMOVE THE WHEEL FROM SERVICE IMMEDIATELY. THIS INCLUDES ANY HEAT DAMAGE TO THE TIRE, DISCOLORATION TO THE WHEEL, AND OR BRAKE DRUM, AND ANY BURNT OR CHARRED LABELS.**

2



# Dimension checks

2-4

## Open Side Circumference Check



**WARNING**

**WARNING** Wheels that have been subjected to high pressure tire and rim separation or excessive heat damage may no longer have sufficient dimension and contour to retain the tire bead while under pressure.

Exploding wheel/tire assembly can cause serious injury or death.

Immediately and permanently remove from service any wheel that has been exposed to high pressure tire and rim separation or excessive heat.



**WARNING**

**WARNING** Wheels that have been run flat or have other physical damage may no longer have sufficient dimension and contour to retain the tire bead while under pressure.

Rims that lack proper dimension and contour can lead to explosive separation of the tire and rim, causing serious injury or death.

Any wheel that has been in service must be inspected prior to mounting. Follow dimension check procedures described in this section during each wheel inspection.

Best Inspection Method

Photo to the right shows the TRA Ball Tape



Measure the circumference of the bead seat on the open side (see illustration to left) with a ball tape.

The circumference of the bead seat on the open side of the wheel should be checked at each tire change. The open side is the side opposite the disc face. In the case of center flange wide base wheels, or wheels with insets less than 3 inches, both rim flanges should be checked. Any wheel should be inspected prior to mounting. If the circumference of the bead seat does not match the required dimension as indicated by the TRA certified ball tape, immediately and permanently remove the wheel from service.

Ball tapes used for measuring wheel circumference can be purchased from the Tire and Rim Association, Inc., 175 Montrose West Avenue, Copley, Ohio 44321. (330) 666-8121 or at [www.rma.org](http://www.rma.org). For instructions on proper use of ball tape, reference the current Tire and Rim Association yearbook.

2nd Best Inspection Method

If a ball tape is unavailable

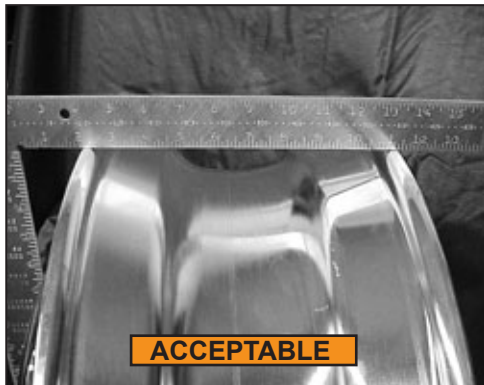

**ACCEPTABLE**



**UNACCEPTABLE**

Photo above shows carpenter square even on both bead seats.

Photo above shows an undersized wheel that you can clearly place a credit card (approximately .030in. or .76mm) between the square and the wheel.



Dual wheel



Non-Dual wheel

### THIS INSPECTION TECHNIQUE ONLY APPLIES TO DUAL OR DISC FACED WHEELS

Check all wheels at each tire change for proper contour of the open side of the rim. Place the long leg of a carpenter square across the center of the disc side of the wheel. Extend the short leg across both rim flanges of the wheel as shown above. Repeat this process at four equidistant points around the wheel.

The short leg should touch both rim flanges at each point. If a distance greater than the thickness of a credit card (or .030 in. or .76mm feeler gauge) appears between the short leg and the rim flange, the wheel should be removed from service and scrapped.

If a ball tape or carpenter square is unavailable, roll the unmounted wheel without a tire a minimum of 10 feet over a smooth, flat, level, clean surface such as asphalt or concrete pavement. Any deviation from rolling in a straight line is an indication of a potential lack of proper dimension and contour. Remove the wheel from service until it can be properly checked with a ball tape.

3rd Best Inspection Method

Rolling wheel as described on this page

**IF YOU DO NOT FULLY UNDERSTAND ANY OF THESE INSPECTION METHODS AS DESCRIBED IN THIS SECTION CONTACT ALCOA AT 800-242-9898 FOR CLARIFICATION.**

## Dimension checks (continued)

### Tire Wear or Ride Problems

If you experience tire wear or ride problems it may be helpful to check radial run out. Remove the wheel from the vehicle, deflate and remove the tire (see Section 3-5 for recommendations and instructions for demounting tubeless tires).

Remount the wheel on the vehicle without the tire. Be sure to follow proper mounting procedures to assure the wheel is well centered on the hub. Place a dial indicator as illustrated below to trace the bead seats of the wheel. Rotate the wheel, noting the amount of variation shown on the dial indicator. Note: Alcoa aluminum wheels should be tested for radial run out only at the bead seat surface. A total indicator reading of .030 inches or less is acceptable.



Tire wear can also be caused by improperly seated tires. Inspect the tire for proper seating on the wheel. The tire beads may not be seated properly. If so, remove the wheel from the vehicle, deflate and break the bead seats (see Section 3-5 for recommendations and instructions for demounting tubeless tires). Adequately lubricate the bead seats and properly re-seat the tire beads. Reinflate the wheel in a safety cage or other suitable restraint (refer to OSHA rule 1910.177, paragraph b, see Section 6).

## Cracked or damaged wheel checks



**WARNING**

**WARNING** Cracked or damaged wheels may fail or come off the vehicle.

Wheels that fail or come off the vehicle while it is moving can cause serious injury or death.

Immediately and permanently remove cracked or damaged wheels from service.

Visually inspect wheels for cracks or damage. Remove wheels from service with known or suspected damage.



## Mounting area

2-6

Stud hole cracks are usually caused by improper torquing (see Sections 4-8 and 5-2), excessive loading or insufficient mounting flange support by the hub or brake drum. Remove wheel from service.

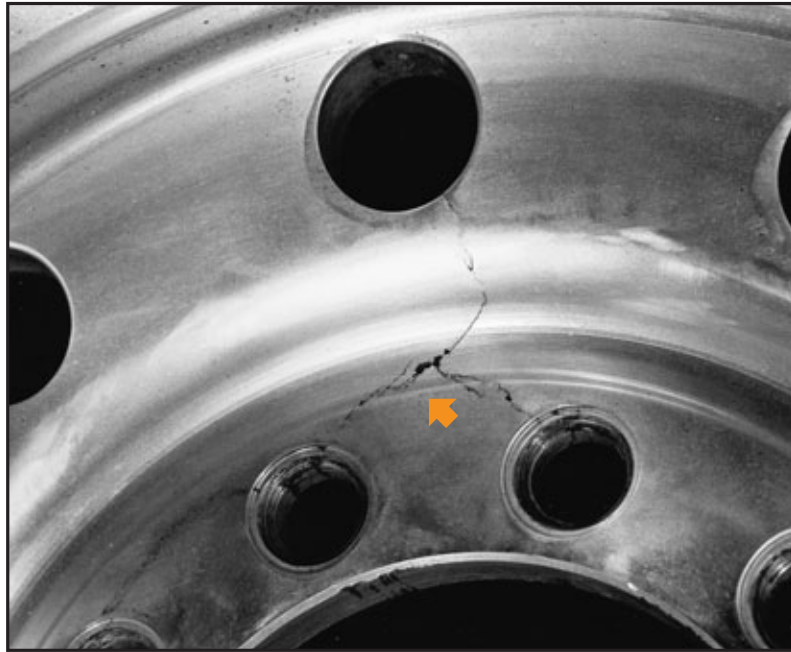

Shown below are stud hole cracks emanating from bolt hole to bolt hole. Causes are: undersized diameter of wheel support surface (see specifications on next page), support surface not flat, incorrect attachment parts (see Section 4-2) and insufficient torque (see Sections 4-8, 4-11, 5-2). Remove wheel from service.

Support surface should be flat to the diameter recommended on the chart on the following page.

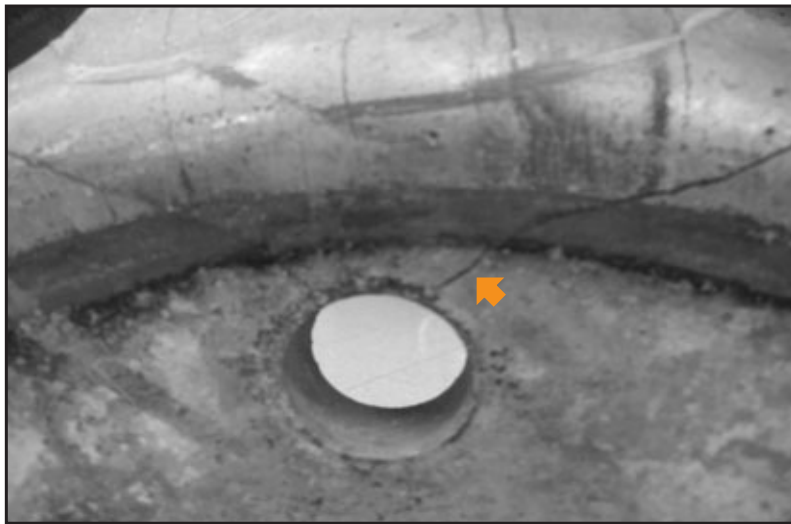

Inspect the hub/drum contact area thoroughly for cracks or other damage.

1

2

3

4

5

6

7

8

## Mounting area (continued)

### Support Surface Diameters

Support surface should be flat to the diameter recommended per SAE J694:

Number of Bolts	Bolt Circle	Mounting Type	Backup Diameter	Thread Size
10	11.25 inch	U.S. Stud pilot	13.2-13.5 in.	.750/1.125 in.
10	285.75mm	Hub pilot	13.2-13.4 in.	22mm
10	335mm	Hub pilot	15.0-15.2 in.	22mm
8	275mm	U.S. Stud pilot	13.2-13.5 in.	22mm
8	275mm	ISO Hub pilot	12.4-12.6 in.	20mm

## Corrosion

Certain environments can lead to corrosion. Some of the more common corrosive materials are: salt, magnesium chloride and calcium chloride compounds used for snow removal and highly alkaline materials. If the air used to fill tubeless tires, or the tire itself, is not dry, the areas of the wheel under the tire can corrode severely.

2-7

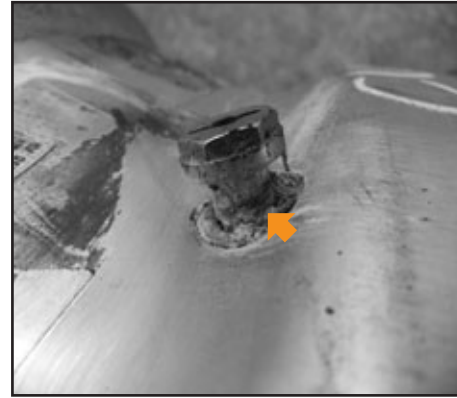
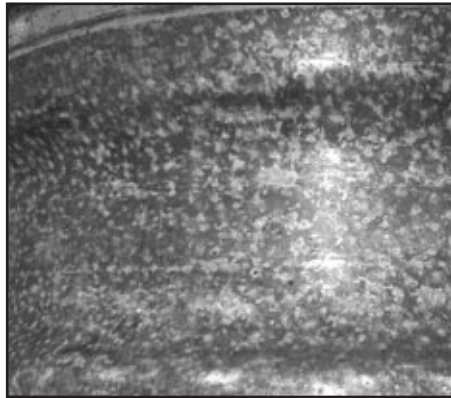

Bead seat and valve stem corrosion often are caused by entrapped moisture. Mild corrosion as shown in pictures to left should be removed thoroughly by wire brush and the rim protected with non-water-based tire lubricant (see Section 3-1). Remove any severely corroded (0.125 inches deep) wheel from service.

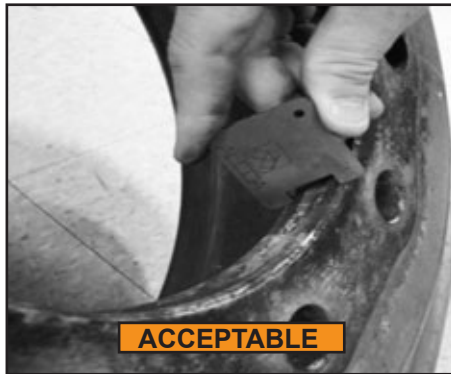

**ACCEPTABLE**

Hub bore gauge does not fit.



**UNACCEPTABLE**

Hub bore gauge with severe corrosion. Remove any severely corroded wheel from service.



CAUTION

**CAUTION** The use of liquid tire balancers or sealants in Alcoa wheels may cause extremely rapid corrosion of the wheel rim surface. Alcoa wheels corroded by the use of liquid tire balancers or sealants will not be replaced under the Alcoa limited warranty.

Severely corroded wheels are unsuitable for service.

## Bolt holes

If wheels are run loose, both stud located wheels and hub piloted wheels can be damaged. Look for wallowed out or elongated ball seats on stud located wheels. On hub piloted wheels look for elongated stud holes. Over torquing can lead to damaged ball seats on stud located wheels and can damage the disc surface of hub piloted wheels. Remove damaged wheels from service.

### 2-8



For hub piloted - normally if you see thread marks on the inside diameter of the bolt holes, this would indicate the wheel ran loose.

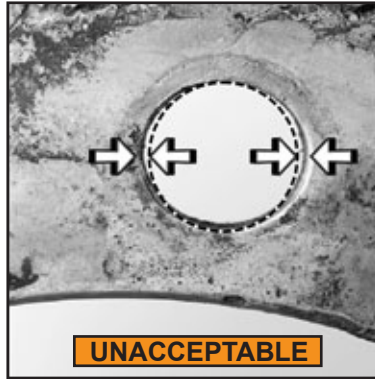

For hub piloted - normally if you see a wallowed out bolt hole, this would indicate the wheel ran loose.

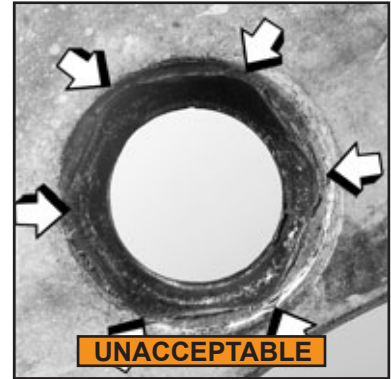

Damaged ball seat contact area. Pounding of nut on ball seat contact area identified by arrows.

## Disc area

### 2-9

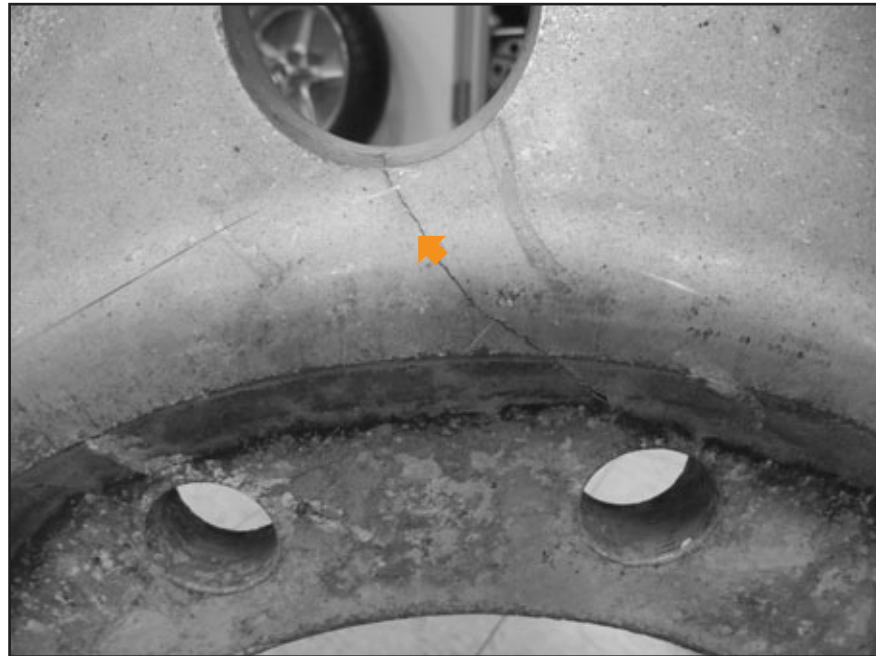

Inspect both sides of disc area for hand hole cracks. If cracks are found, remove the wheel from service.

### Rim area

Check the entire rim area for nicks, gouges and cracks. Loss of air may be caused by cracks in areas around the valve stem hole. Remove the wheel from service.

### 2-10

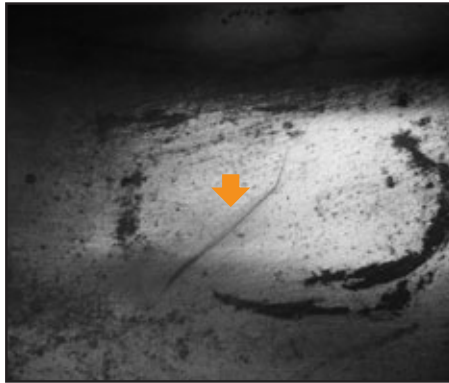

Drop center crack



Valve hole crack

### Bead Seat area

Loss of air may be caused by cracks in the bead seat areas around the rim. Remove the wheel from service if damaged.

### 2-11

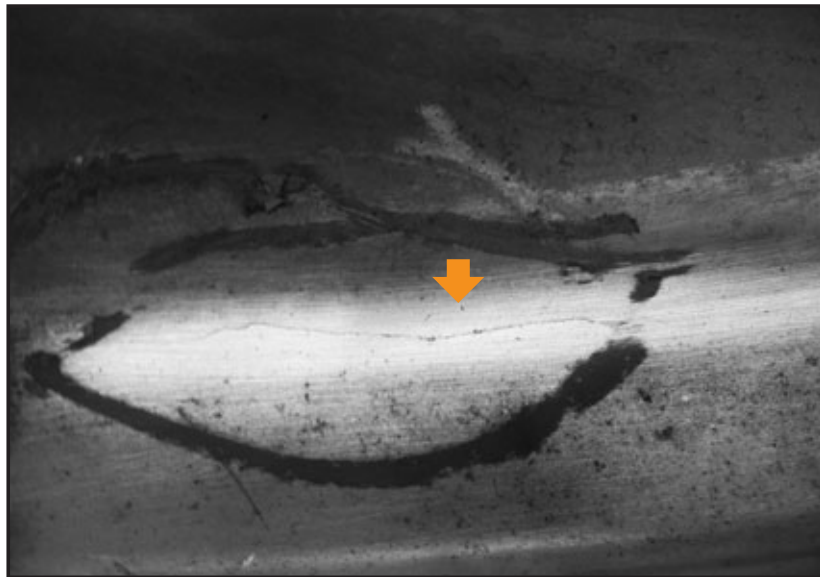

Bead seat cracks are normally caused by overloading of the wheels. If you have this type of wheel breakage it would be recommended to use SEVERE SERVICE WHEELS. Please see Alcoa Wheels Product Spec Guide for part numbers and wheel descriptions of the Severe Service Wheels.

## Rim flange wear

2-12

Rim flange wear is not a warrantable issue. Only Dura-Flange® wheels have a warranty on rim flange wear against sharp edges for a 24 month warranty period.

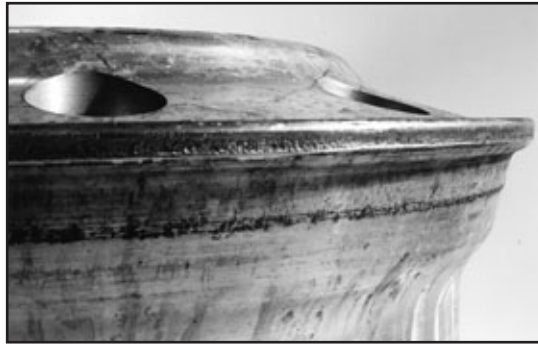

Irregular wear on the surface of the rim flange is caused by abrasion from the tire chafer and sidewall. Rim flange wear happens most often in applications with heavy or shifting loads. If you are experiencing excessive rim flange wear in your operation, consider using Alcoa Dura-Flange® aluminum wheels. These wheels have been specially treated to significantly reduce rim flange wear. Remove wheels from service when rim flange wear is excessive. Excessive wear can be determined using an Alcoa approved wear gauge and procedures detailed below. If rim flange wear becomes sharp and/or cuts the tire, contact Alcoa for recommended maintenance procedures.

THESE GAUGES ARE TO BE USED FOR RIM FLANGE WEAR ONLY.  
THEY ARE NOT A BEAD SEAT ANGLE OR DIAMETER TOOL

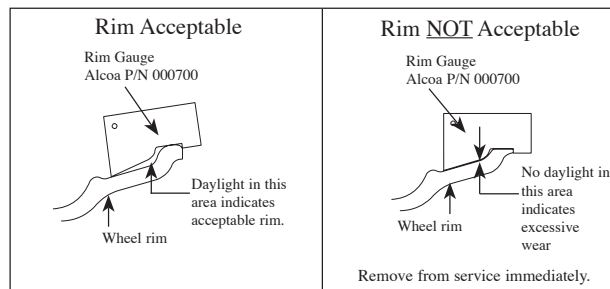

To obtain a gauge(s) at no charge and information on free training on proper installation and maintenance procedures, contact Alcoa Wheel and Transportation Products at (800) 242-9898 or on the web at [www.alcoawheels.com](http://www.alcoawheels.com).

### Determining Rim Flange Wear

STEP 1. Remove the wheel/tire assembly from the vehicle. Remove the valve core to deflate the tire completely. Remove the tire from the wheel according to OSHA regulations, TMC recommended practices for tire and rim safety procedures and/or the Alcoa Wheel Service Manual.



Photo 1a



Photo 1b



## Rim flange wear (continued)

STEP 2. After the wheel is separated from the tire, verify that the circumference of the bead seat on the open side is acceptable (see Section 2-4). Check the wheel flange with the Alcoa Rim Flange Wear Gauge to determine if the wheels must be removed from service for excessive rim flange wear (photos 1a and 1b on previous page).

See Rim Flange Wear Gauge Instructions on the illustrations on previous page to make this determination. If you do not have an Alcoa Rim Flange Wear Gauge, contact Alcoa Wheel and Transportation Products to obtain a gauge(s) at no charge by calling (800) 242-9898 or on the web at [www.alcoawheels.com](http://www.alcoawheels.com).

STEP 3. If the wheel is deemed to be serviceable by the rim flange gauge, examine the wheel flange edge for sharpness by using a rubber sharpness gauge. These gauges are constructed by having a section of tire side wall or a suitable piece of rubber attached to a block of wood (photo 2). By running the sharpness indicator gauge along the wheel in the area of the wear, determine if the wear is sharp enough to cut or damage the rubber on the sharpness indicator (photo 3). If the rubber is cut, then follow the edge removal instructions below.



Photo 2. A rubber sharpness gauge or a suitable piece of rubber attached to a block of wood.

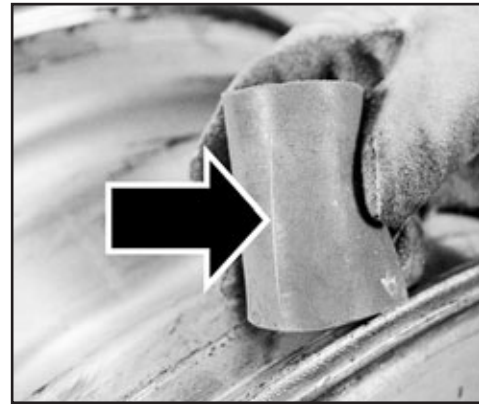

Photo 3. Run the sharpness indicator gauge along the wheel in the area of the wear to determine if the wear is sharp enough to cut or damage the rubber on the sharpness indicator.

**NOTICE:** Examine the tire for cuts in the bead area and side wall. If no damage occurred to these areas, return the tire to service. Cut tires should be removed from service. The tire should be inspected at this time for any other damage and be treated per normal tire procedures recommended by the tire manufacturer.

**NOTICE:** Check the wheel at every tire change or ONCE PER YEAR for rim flange wear and any sharp edges. If you follow this practice, you will significantly reduce the possibility of a rim flange cutting into the tire.

If the flange cuts or appears close to being sharp enough to cut the rubber on the sharpness indicator gauge, the edge can be removed per the edge removal procedures on the following page. If the rubber is not cut, then the wheel can be returned to service without further work for rim flange wear.



CAUTION

CAUTION Do not run unprotected hands or fingers across worn rim flange areas of used wheels.

Worn rim flange areas are sharp and can cut hands or fingers. Cuts can lead to infection.

Always wear gloves when handling used wheels or when testing for edge sharpness.

## Rim flange wear (continued)

### Edge Removal Procedures

There are many tools available to remove the sharp edge on the wheel caused by rim flange wear. Here are some examples of commonly used tools:

File. A file can be used very effectively to remove the edge (photo 4).



Photo 4. Removing sharp edge by hand with a metal file.

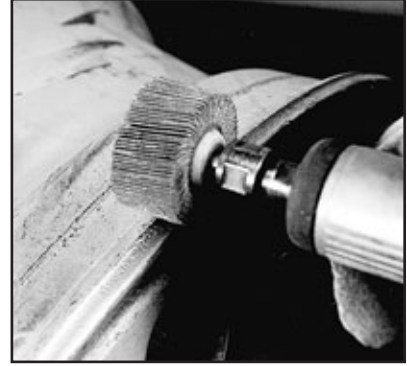

Photo 5. Air or electric power sander.

Air or Electric Powered Sander. This provides a very quick and effective method of removing the edge. Operators should use all care to keep a uniform edge when using these tools (photo 5).

Air or Electric Grinder. This is another quick and effective method of removing the sharp edge caused by rim flange wear. Be careful as grinding pads may “gum up” from the aluminum that is removed (photo 6). Care must be used to avoid gouging the wheel.



Photo 6. Grinder



Photo 7. Grinder.

## Rim flange wear (continued)

Die Grinder. Used with a sanding wheel, cutting stone or grinding tool, this is a version of an electric grinder. This tool is very quick and effective as well, and care must be taken to remove metal as uniformly as possible and not to gouge the wheel (photo 7 on previous page).



CAUTION

CAUTION Removing sharp edges with hand or power tools produces metal filings and sparks. Many power tools have edges that are sharp or may become hot during use. Some power tools produce excessive noise when used.

Metal filings can be sharp and, when projected by the action of power tools, can cause serious skin or eye damage. Excessive noise from power tools can harm hearing. Sharp edges can produce cuts and hot surfaces can cause burns. Cuts and burns can lead to infection.

Always wear appropriate safety gear such as protective eye wear, gloves, protective clothing and hearing protection when using hand or power tools.



Photo 8. Severe rim flange wear.



Photo 9. Sharp edge removed.

STEP 4. These photographs show the results of removing the edge. With whatever tool is selected, work the tool around the wheel's circumference removing only enough material to eliminate the sharp edge. This should only be a small amount of metal. Perform this work on both flanges if there is evidence of sharpness.

Regardless of the method which you choose, the objective is to remove only the sharp edge (photo 9). Remove just enough metal to smooth the edge. Take care to make sure the edge removal is as uniform as possible. Avoid gouging the wheel.



## Rim flange wear (continued)

STEP 5. After the edge is removed, run the sharpness indicator gauge along the area of edge removal to check for any remaining sharpness. If the rubber is still cut, perform the steps again to remove the sharp edge. Always remove the minimum amount of material necessary to eliminate the sharp edge.

STEP 6. Check the rim flange height with the Alcoa Rim Flange Wear gauge to make sure there is adequate height remaining to safely support the tire. The photograph at the bottom of the previous page again shows how this gauge is used. Be sure to move the gauge all around the wheel's circumference and make sure that no area of the flange is below what the gauge indicates is acceptable. If the entire wheel flange is within the limits of the rim flange wear gauge, the wheel may be returned to service.

STEP 7. Always inspect the wheel for any other conditions that would warrant removal from service. Consult the Alcoa Wheel Service Manual or the TMC User's Guide to Wheels and Rims.



**WARNING**

**WARNING** Welding or brazing the rim flange or any area of an Alcoa aluminum wheel will weaken the wheel. Weakened or damaged wheels can lead to an explosive separation of tires and wheels or wheel failure on the vehicle.

Explosive separations of tires and wheels or wheel failure on the vehicle could cause serious injury or death.

Never attempt to weld or braze any surface of an Alcoa aluminum wheel.



**WARNING**

**WARNING** Returning wheels to service with inadequate flange height as determined by the Alcoa Rim Flange Wear Gauge can lead to an explosive separation of tires and wheels.

Explosive separations of tires and wheels on the vehicle could cause serious injury or death.

Wheels with flange height that falls below the Alcoa gauge have inadequate rim flange height to support the tire on the rim. Immediately and permanently remove any wheel from service that has inadequate rim flange height.



**WARNING**

**WARNING** Excessive heat from fire, brake malfunction, wheel bearing failure, tire failure or other sources may weaken the metal and cause the wheel/tire assembly to separate explosively.

Exploding wheel/tire assembly can cause serious injury or death.

Immediately and permanently remove from service any wheel that has been exposed to excessive heat.

Always follow safe mounting procedures as recommended using OSHA approved tire inflation cages. See the Alcoa Wheel Service Manual or OSHA safety wall charts and procedures.

## Dura-Flange® maintenance

### 2-13

1. Dura-Flange® has a 24 month warranty against wear which creates a sharp edge that would require maintenance per section 2-12.
2. Minor wear or minor pitting is not a warrantable condition.
3. Edge re-conditioning cannot be performed on Dura-Flange® wheels including those methods as described in Section 2-12.

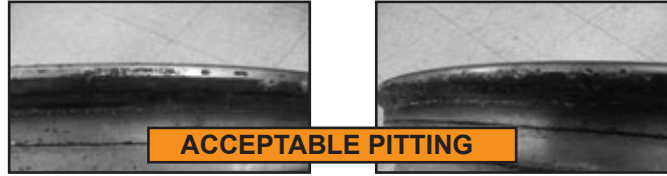

## Maintenance against corrosion (non-Dura-Bright® surface treated wheels)

### 2-14

The following information is for standard Alcoa forged aluminum wheels without the Dura-Bright® surface treatment. (See Section 2-15) for specific instructions on the care and cleaning of Alcoa Dura-Bright® surface treated wheels.

1. Clean frequently with high pressure water from a hose. The use of a mild detergent will speed the cleaning process. Use no harsh alkaline cleaners.
2. When tires are removed the entire wheel must be cleaned and inspected. (See Section 2). With a wire brush, remove any foreign products from the tire side of the rim. Do not use a wire brush to remove dirt and corrosion products from the appearance surface of the wheel. Generously coat the entire air chamber surface with an approved surface protectant and lubricant each time the tire is removed (see Section 3-1).
3. To maintain the original appearance of your Alcoa wheels, the following procedures are recommended:
  - a. After installing new wheels and prior to operating your vehicle, use a sponge, cloth or soft fiber brush to wash exposed wheel surfaces with a mild detergent and warm water solution.
  - b. Rinse thoroughly with clean water.
  - c. Wipe dry to avoid water spots.
  - d. Wax the cleaned surface with any automotive polish.
  - e. Clean your Alcoa truck wheels as frequently as required to maintain their appearance.

## Dura-Bright® surface treated wheels cleaning and maintenance

### 2-15

1. The Dura-Bright® surface treatment is designed to be easy to clean and generally only requires water. If soils attached to the surface do not come off with cold water, try warm water and wipe with a soft towel or chamois material. If soils remain, use warm water and a mild detergent (with assistance of a commercial high pressure power washer, if available). Always dilute the detergent according to the manufacturer's recommendation; never use the detergent straight without diluting with water. In the mixed, diluted state the cleaner acidity should be at pH equal or greater than 5; avoid cleaners that contain any hydrofluoric acid. In the mixed, diluted state the cleaner alkalinity (basicity) should be at pH equal or lower than 9.
2. When tires are removed, the entire rim must be cleaned and inspected (see Section 2). With a soft brush, remove any foreign products from the rim (portion of the wheel that supports the tire). Generously coat the entire air chamber surface with an approved surface protectant and lubricate each time the tire is removed (see Section 3-1).
3. Once in service, Dura-Bright® wheels can become nicked or scratched by road debris and/or mechanical damage. If this occurs, continue to follow the normal washing and cleaning instructions provided above.
4. Even as durable as Dura-Bright® wheels are, the mounting area can become scratched, marred or discolored when mounted against another wheel, hub or drum. The use of a wheel mounting surface guard, such as high temperature nylon spacers, is highly recommended.
- Note: pH value can be found in chemical MSDS (Material Safety Data Sheet). If the cleaner is in concentrated form, contact your cleaning chemical supplier to determine pH levels.

Only Alcoa's Warranty Center can authorize warranty claims and determine justified warranty returns. Dura-Bright® and Dura-Flange® claims can only be authorized and determined by Alcoa's Warranty Center.



# 3

# Mounting Alcoa wheels with Tubeless Tires

## Recommendations for mounting tubeless tires

### 3-1

**NOTICE:** For information on tube type wheels, contact Alcoa at (800) 242-9898 Option 1.

**NOTICE:** Alcoa aluminum non-symmetrical wheels require special tire mounting techniques, see Section 3-3.

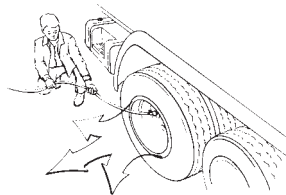

**WARNING** Damaged tires or wheels can lead to an explosive separation of tires and wheels.

Explosive separation can cause serious injury or death.

Inspect tires and wheels for damage before removing from vehicle. If damage is found, the tire must be completely deflated before loosening cap nuts. Immediately and permanently remove damaged tires or wheels from service.



**WARNING** Use of inner tubes in tubeless wheels will hide slow leaks. Slow leaks may indicate cracked (see Section 2-10, 2-11) or damaged wheels which lead to wheel failures.

Wheel failures can cause accidents which may result in serious injury or death.

Never use an inner tube on an Alcoa tubeless wheel. Immediately and permanently remove cracked or damaged wheels from service.

1. Do not gouge or nick the wheel. Place aluminum wheels on clean floor and use a protective mat when hand mounting tires. Additional care should be used when mounting Alcoa Dura-Bright® surface treated wheels since minor nicks and scratches cannot be polished out (see Section 2-15, pages 16 for specific cautions, care and maintenance procedures).
2. Always use a rubber, leather-faced or plastic mallet.
3. Inspect the wheel for damage. Do not use a damaged or severely corroded wheel (see Section 2).
4. Clean the wheel disc face and the tire bead seat areas. Be sure the wheel is dry before applying tire lubricant.
5. Inspect the tire for damage. Be sure the inside of the tire is dry before it is mounted.
6. Use of a non-water-based lubricant is recommended as a rim surface protectant and tire mounting lubricant. Coat the entire rim surface (see Section 2-2).
7. Lubricate the rim and tire bead immediately before mounting the tire. Do not use any lubricant which contains water. Water-based lubricants can promote corrosion attack on the rim surface. The use of non-water-based lubricants is especially important when mounting tubeless tires as the air in the tire is contained by the seal between the bead and tire rim.
8. Never lubricate the rim or tire bead with a flammable solution. This can lead to an explosion during airing of the tire or in subsequent operation of the vehicle (see Warning on next page).
9. If using a tire mounting/demounting machine on aluminum wheels, care should be taken to prevent gouging the wheel.
10. Use only dry air for tire inflation. The use of moisture traps in the air compressor feed line is recommended.
11. Do not overinflate. Use the tire manufacturer's recommended pressure, but under no circumstances exceed cold tire pressures roll stamped on the wheel.
12. When inflating a tire always use a clip-on air chuck or threaded straight chuck and a remote valve with pressure gauge. Stay out of trajectory of wheel.

## Recommendations for mounting tubeless tires (continued)



**WARNING**

**WARNING** Never use a volatile or flammable material, such as ether or gasoline, as an aid to seating the tire beads on the wheel. Such use can lead to an uncontrolled pressure build-up in the tire and may result in an explosion.

Explosive separation of the tire and wheel can occur while seating beads in this manner, while adding air to the tire on or off the vehicle, or later on the road. Loss of vehicle control can result, which can cause serious injury or death.

Only use approved mechanical or pneumatic bead seating devices.



**WARNING**

**WARNING** A pressurized tire/wheel assembly can explode and separate violently.

This violent separation can cause serious injury or death.

Always contain the tire/wheel assembly in an inflation cage during inflation.

## Mounting tubeless tires

### 3-2

**NOTICE:** Not all tire mounting/demounting machines work alike. Be sure to read the operating or instruction manual for your particular machine before attempting to mount or demount tires.

**NOTICE:** Do not exceed maximum wheel load. Customer must compare OEM vehicle load rating to maximum wheel load rating.

Refer to tire manufacturer's recommendation for proper tire pressure. Before mounting the tire perform a wheel fitment check to insure proper clearance from any obstructions.

**NOTICE:** When match mounting tires on Alcoa wheels locate valve stem adjacent to low point mark on the tire.

**NOTICE:** Alcoa aluminum 19.5" non-symmetrical wheels require tires to be mounted and demounted over the disc side of the wheel only.

**NOTICE:** Refer to tire manufacturer's recommendation for proper tire pressure.



Lubricate wheel and tire bead using approved lubricant. Tire beads should be mounted over the rim flange closest to the wheel well. Push bead over flange as far as possible.



Insert curved end of tool between bead and wheel flange with tool stop against flange. In circular motion, use short successive bites to work the bead over the flange. Push down on tool as bead is worked over flange.



Lubricate the second tire bead. Start second bead into the well, holding it in position with the clamp to the rim flange. Lubricate bead half way around. With curved end of tool between tire bead and flange, and the stop towards the wheel, push tool outward to work tire over flange. Continue to pry bead over flange using the tool until remaining bead is over flange. Seat the tire bead using an air ring or other mechanical bead seating aid.



Place tire/wheel assembly inside safety cage or other suitable restraint (refer to OSHA rule 1910.177, paragraph b, see Section 6). Refer to tire manufacturer's recommendation for proper tire pressure. Using a clip-on air chuck or a self-locking straight chuck with remote valve and pressure gauge, inflate the tire/wheel assembly to proper pressure. Be sure to stay out of the trajectory of potential exploding parts or air blasts.

## Mounting tubeless tires (continued)

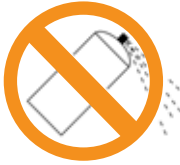

**CAUTION** The use of liquid tire balancers or sealants in Alcoa wheels may cause extremely rapid corrosion of the wheel rim surface. Alcoa wheels corroded by the use of liquid tire balancers or sealants will not be replaced under the Alcoa limited warranty.

Severely corroded wheels are unsuitable for service.

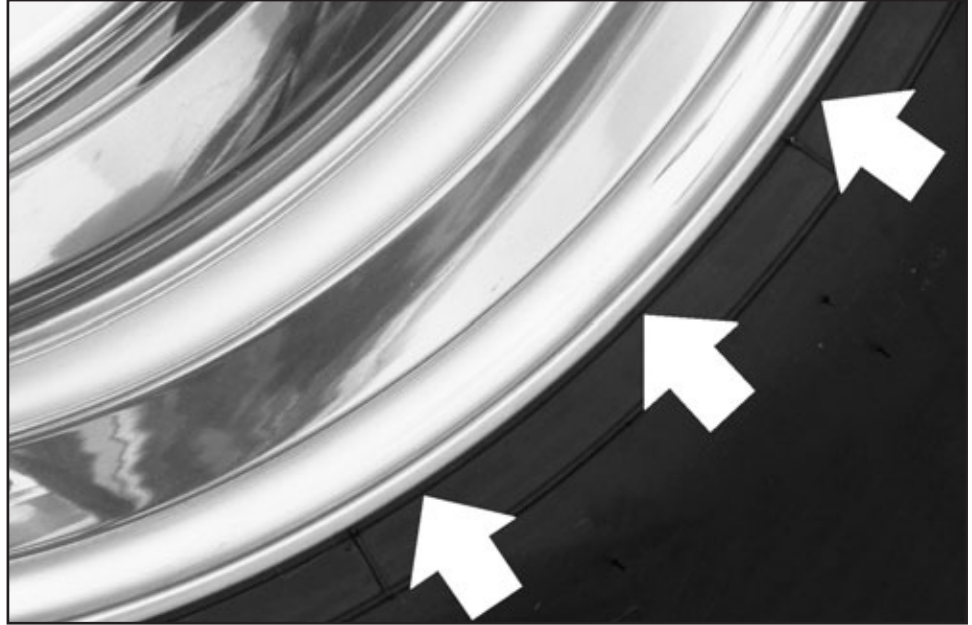

Heavy duty truck tires have a "guide rib" or "ring" molded into the sidewall next to the tire bead. When the tire is inflated this ring should be evenly spaced from the wheel rim all the way around the wheel. Check the position of the ring before removing the assembly from the inflation cage. If the ring and wheel are not concentric, deflate the assembly in the cage, re-lube and remount the tire.

## Mounting tires on non-symmetrical drop well wheels

Alcoa wheels usually have a symmetrical drop well with a narrow ledge on both sides of the rim. This feature allows mounting of the tire from either side of the wheel. However, some Alcoa wheels are non-symmetrical and contain a narrow ledge on only one side of the wheel. Reduced well wheels as well as some other wheel designs feature an increased underwell diameter and also have a non-symmetrical sloping rim profile which provides additional brake clearance.

In order to minimize the possibility of tire bead damage, all mounting and dismounting of the tire should be performed only from the narrow ledge side of the wheel in accordance with OSHA regulation.

Tires should be mounted/dismounted only across the disc side of the wheel.

3-3

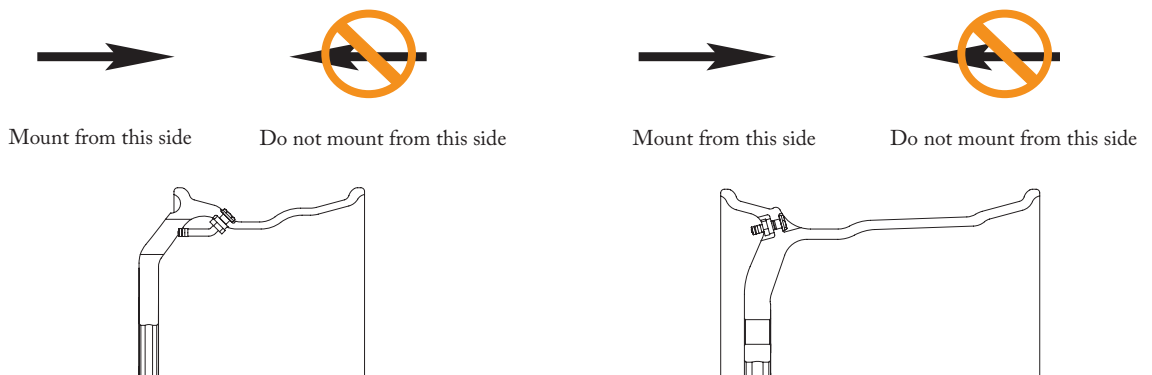

## Rim width to tire matching

3-4

## Rim to Tire Matching Chart for Medium and Heavy Trucks

Tire Size (for both radial and bias tires)	Approved Rim Widths	Tire Size (for both radial and bias tires)	Approved Rim Widths
8R17.5	5.25, 6.00	8R22.5	5.25, 6.00, 6.75
9R17.5	6.00, 6.75	9R22.5	6.00, 6.75, 7.50
10R17.5	6.75, 7.50	235/80R22.5	6.75, 7.50
11R17.5	7.50, 8.25	245/75R22.5	6.75, 7.50
		10R22.5	6.75, 7.50, 8.25
		255/70R22.5	7.50, 8.25
		255/80R22.5	7.50, 8.25
		275/80R22.5	7.50, 8.25
		11R22.5	7.50, 8.25
		265/75R22.5	7.50, 8.25
		12R22.5	8.25, 9.00
		295/60R22.5	8.25, 9.00
		295/75R22.5	8.25, 9.00
		305/75R22.5	8.25, 9.00
		305/85R22.5	8.25, 9.00
		315/80R22.5	9.00, 9.75
		335/65R22.5	9.00, 9.75, 10.5
		15R22.5	11.75, 12.25
		385/65R22.5	11.75, 12.25
		425/65R22.5	11.75, 12.25, 13.00
		16.5R22.5	12.25, 13.00
		18R22.5	13.00, 14.00
		445/50R22.5	14.00
		445/55R22.5	14.00
		445/65R22.5	13.00, 14.00
8R19.5	5.25, 6.00, 6.75	11R24.5	7.50, 8.25
225/70R19.5	6.00, 6.75	275/80R24.5	7.50, 8.25
245/70R19.5	6.75, 7.50	285/75R24.5	8.25
265/70R19.5	7.50, 8.25	12R24.5	8.25, 9.00
445/65R19.5	13.00, 14.00		

There may be additional rim to tire matches not shown above. Contact the tire manufacturer or your Alcoa wheel representative for additional information.

## Recommendations for demounting tubeless tires

3-5



**WARNING**

**WARNING** An aluminum wheel can be structurally weakened by excessive heat.

Tire/wheel assemblies using wheels that have been exposed to excessive heat may experience a sudden and unpredictable tire/wheel separation causing serious injury or death.

Immediately and permanently remove any wheel from service that has been subjected to excessive heat (such as a tire fire, wheel bearing failure or braking system drag/seize) or a high pressure tire/wheel separation.



**WARNING**

**WARNING** Damaged tires or wheels can lead to an explosive separation of tires and wheels.

Explosive separation can cause serious injury or death.

Inspect tires and wheels for damage before removing from vehicle. If damage is found, tire must be completely deflated before loosening cap nuts. Immediately and permanently remove damaged tires or wheels from service.

## Recommendations for demounting tubeless tires (continued)

1. Remove valve core/air from tire wheel assembly prior to removal from vehicle. When hand demounting tires from wheels, placing aluminum wheels on a clean floor and protective mat is recommended. Additional care should be used when demounting Alcoa Dura-Bright® surface treated wheels since minor nicks and scratches cannot be polished out (see Section 2-15, for specific cautions, care and maintenance procedures).
2. Always use a rubber, leather-faced or plastic mallet.
3. Keep tire tools smooth. Use them with care. Rim gouges or nicks may cause cracks.
4. If using a tire mounting/demounting machine on aluminum wheels, care should be taken to prevent gouging the wheel.

## Demounting of tubeless tires

### 3-6

*NOTICE: Not all tire mounting/demounting machines work alike. Be sure to read the operating or instruction manual for your particular machine before attempting to mount or demount tires.*



Remove the valve core from the valve stem to ensure complete tire deflation. Place wheel on machine, lubricate tire and wheel bead area before demounting, then position tool so flat end can be driven between tire bead and rim flange. Straighten tool to a vertical position until bead is separated from wheel.



Repeat procedure at intervals until bead is totally separated from wheel. Repeat procedure on other side of tire. Tire is now ready for demounting. Lubricate the tire bead.



Insert curved end of tire tools between tire and wheel, approximately 10 inches apart. Pull one tool toward center of wheel, then pull second tool in the same manner. To free bead, leave one tool in position, take out and reinsert the other tool, curved end between bead and flange, a short distance from the spanned area. Pry bead free of rim, repeating process until entire bead is free from wheel.



Insert straight end of tire tool between beads and both rim flanges, hooking stop on the tool over second flange. Position inserted tool at 90° angle to tire assembly at top of wheel and lubricate bead areas on both sides of tool. Lean tire assembly toward tool and rock or bounce to pry off the tire.



# 4 Wheel Installation

## Recommendations for proper installation of wheels

### 4-1

**NOTICE:** Do not exceed maximum wheel load. Customer must compare OEM vehicle load rating to maximum wheel load rating.

Refer to tire manufacturer's recommendation for proper tire pressure. Before mounting the tire, perform a wheel fitment check to insure proper clearance from any obstructions.

**NOTICE:** Check for and replace bent, broken, cracked or damaged studs. When replacing broken studs, always replace the studs on each side of the broken stud. If two or more studs are broken, replace all the studs for that wheel position. Check with the stud manufacturer for regular maintenance and stud replacement practices.

All wheel fastener hardware should be grade 8 or metric conversion 10.9. Follow the hardware manufacturer's recommendations when replacing studs.

1. Make sure all wheel cap nuts are properly torqued — check them often (see Section 4-8). If the wheel is loose, the holes will pound out (deform) if stud-piloted or elongate if hub-piloted (see Section 2-8). If some cap nuts are tight and others are loose, the wheel may develop cracks or studs may break. This condition may cause wheel to loosen and disengage from the vehicle. Dirt streaks radiating from stud holes can indicate loose nuts (see Section 2).
2. On ball-seat wheels be sure the end of the socket is smooth or cover the wheel mounting surface with a protective shield prior to tightening the cap nuts. The end of the socket will mar the wheel around the cap nuts if it is not smooth.
3. Keep all component contact surfaces smooth and clean. Dirt or projections on mounting surfaces may lead to loose wheels. Remove all projections resulting from burrs, nicks, etc. Be sure that loose dirt does not fall onto mounting surface during assembly.
4. Do not introduce any foreign objects such as spacers or top hats into the contact surface areas of the mounting system unless approved by Alcoa. Do not paint Alcoa forged aluminum wheels.
5. Additional care should be used when mounting Alcoa Dura-Bright® surface treated wheels since minor nicks and scratches cannot be polished out (see Section 2-15, for specific cautions, care and maintenance procedures).
6. High temperature nylon spacers are a protection gasket designed to be placed between the wheels and also the brake drum/wheel contact surfaces (see Sections 4-2, 4-6, 4-7, 4-9). High temperature nylon spacers are recommended to be replaced when the tire/wheel assemblies are removed and reinstalled.



**WARNING** Wheels that are not properly installed or maintained may not be safe.

Failure to follow proper wheel installation or maintenance practices may result in serious injury or death.

Follow the proper wheel installation and maintenance practices as contained in this Alcoa Wheel Service Manual. For training on proper installation and maintenance, available free of charge from Alcoa, or for the most recent updates, contact Alcoa Wheel and Transportation Products at 1-800-242-9898 or on the web at [www.alcoawheels.com](http://www.alcoawheels.com).

# Wheel cap nuts & Wheel mounting tool

## 4-2



**WARNING**

**WARNING** Use of chrome-plated cap nuts which have chrome plating on the surfaces that contact the wheel can cause reduced and inconsistent wheel clamping.

This condition can cause wheels to loosen and disengage from the vehicle, causing serious injury or death.

Never use cap nuts with chrome-plated contact surfaces. Use only recommended hardware on Alcoa aluminum wheels.

There are many types of nuts and studs in use, and their design and specifications are not standardized. The "R" and "L" on cap nut part numbers indicate right and left-hand threads respectively. Alcoa recommends the following cap nuts for use with Alcoa aluminum truck wheels:

### Cap Nuts and Sleeves

*NOTICE: One-piece flange nuts are not approved for use on any Alcoa wheel application.*



2-piece, 26.25 mm height, 33mm hex head flange nut. Mounts single and dual wheels to wheel centering hubs. Right hand threads used on both sides of vehicle. P/N 39874 (supersedes P/Ns 39701 and 39691); M22-1.5 RH threads.



2-piece, 50mm height, 33mm hex head flange nut. Mounts single wheels to wheel centering hubs with 32mm bolt holes. Right hand threads used on both sides of vehicle. P/N 430632; M22x1.5 RH threads. \*Available in Dacromet corrosion resistant coating, P/N 578632.



2-piece, 78.5 mm height, 32mm bolt holes to wheel centering hubs. Right hand threads used on both sides of vehicle. P/N 430732; M22x1.5 RH threads. \*Available in Dacromet corrosion resistant coating, P/N 578732.



Inner cap nut, inner thread 3/4" X 16, outer thread 1-1/8" X 16. For use with steel inner dual wheel and aluminum outer dual wheel with 1.31" (1-5/16") to 1.44" (1-7/16") stud standout. P/N 7896R, 7896L (Grade 8).



1-1/8" X 16 cap nut. Mounts standard single wheels and wide base wheels to 1-1/8" studs. Also mounts outer dual wheel to 1-1/8" inner cap nut. P/N 5996R, 5996L (replaces P/N 5552R, 5552L).



Inner cap nut for use with standard length studs (1.31" [1-5/16"] to 1.44" [1-7/16"]) stud standout) or longer studs not to exceed 1.88" (1-7/8") stud standout. Full internal and external threads, counter bore 5/16" deep at open end. Prevents stud from bottoming out in cap nut. P/N 5988R, 5988L (Grade 8). For use with studs with exposed shoulders. Do not use with steel inner dual wheel.



3/4" X 16 cap nut. Mounts standard single wheels and wide base wheels to 3/4" studs. Do not use on steel wheels. P/N 5995R, 5995L (replaces P/N 5554R, 5554L).



Wheel Mounting Tool. The Alcoa Wheel Mounting Tools are designed to: align wheel bolt holes, seat brake drums that have .980" diameter bolt holes, and prevent thread damage to M22x1.5 studs. P/N 000426.

## How to measure stud standoff

Stud standoff is measured from the axle end mounting surface (the hub, for inboard mounted drums, and the drum, for outboard mounted drums) to the first complete thread at the outside end of the stud.

### 4-3

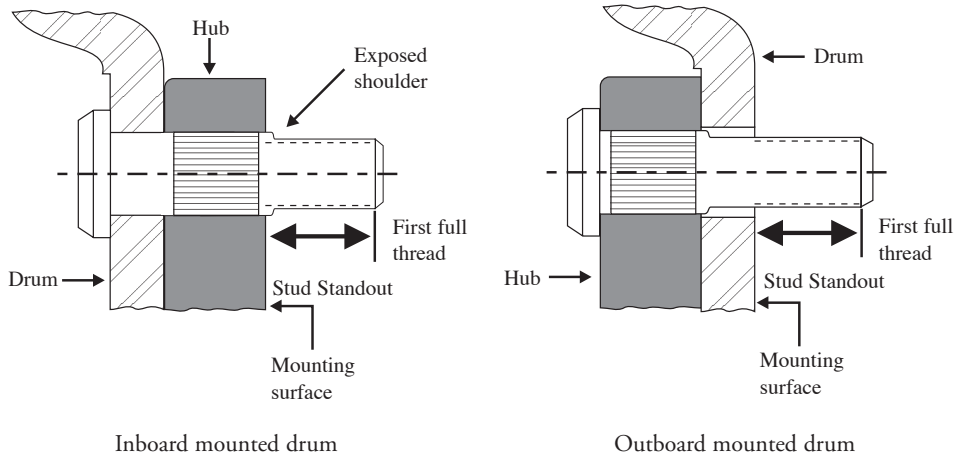

4

## Stud located ball seats are spherical

The nut seat for the stud located ball seat mounting system is a precision-machined spherical surface. Cap nuts must be properly manufactured to assure correct seating. Never use one- or two-piece flange nuts on a wheel designed with ball seats (see Section 4-11). Ball seat cap nuts may be obtained from your Alcoa Wheel Distributor.

### 4-4



## Stud Piloted Mounting System

Front wheels are mounted as singles and require 1.8" (45.7mm) minimum stud standoff. Most vehicles have 1-1/8" studs on the front hubs. Alcoa single cap nuts, P/Ns 5996R and 5996L, or equivalents, should be used. Some front hubs have 3/4" studs. On these hubs, use Alcoa single cap nuts, P/Ns 5995R and 5995L or equivalents.

### Single and wide base wheel, stud located, ball seat mounting

High temperature nylon spacers are recommended for use with Alcoa Dura-Bright® surface treated wheels to protect the wheel contact surfaces from marring. High temperature nylon spacers are placed between the contact surfaces of the Dura-Bright® wheel and the brake drum.

### 4-5

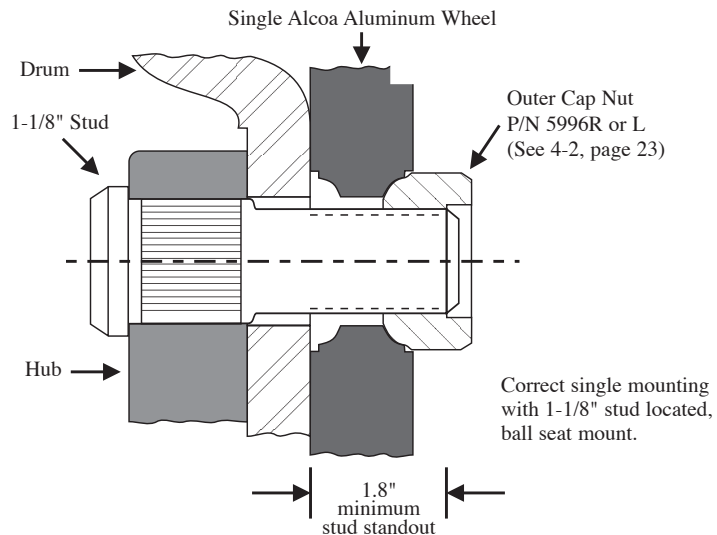

Continued on the next page

## Single and wide base wheel, stud located, ball seat mounting (continued)

**NOTICE:** Do not exceed maximum wheel load. Customer must compare OEM vehicle load rating to maximum wheel load rating.

Refer to tire manufacturer's recommendation for proper tire pressure. Before mounting the tire, perform a wheel fitment check to insure proper clearance from any obstructions.

**NOTICE:** Check for and replace bent, broken, cracked or damaged studs. When replacing broken studs, always replace the studs on each side of the broken stud. If two or more studs are broken, replace all the studs for that wheel position. Check with the stud manufacturer for regular maintenance and stud replacement practices.

All wheel fastener hardware should be grade 8 or metric conversion 10.9. Follow the hardware manufacturer's recommendations when replacing studs.

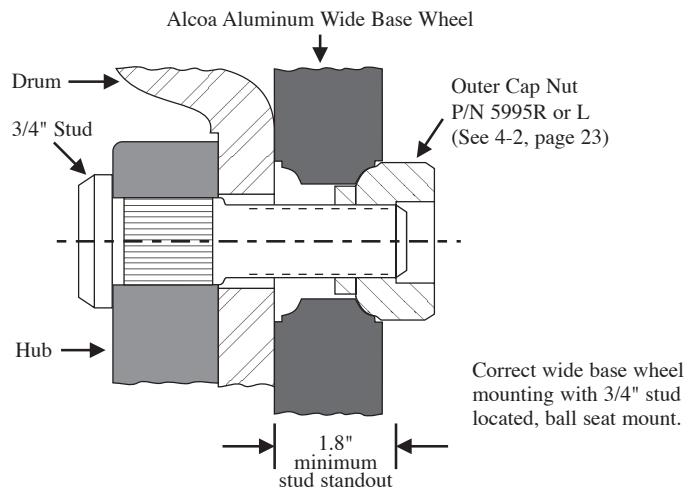
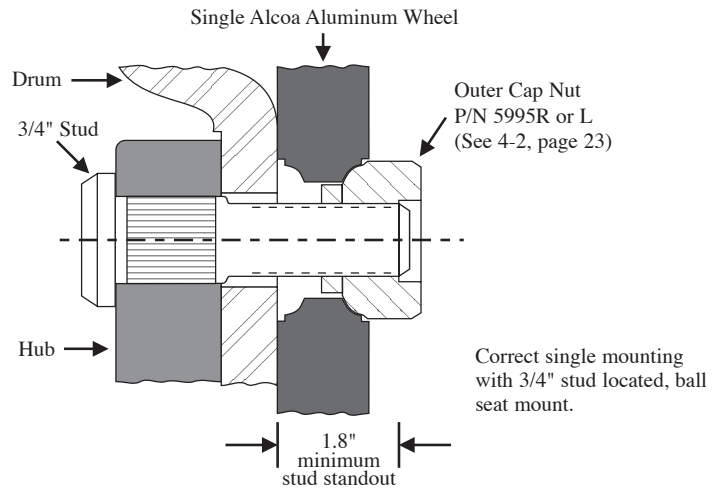
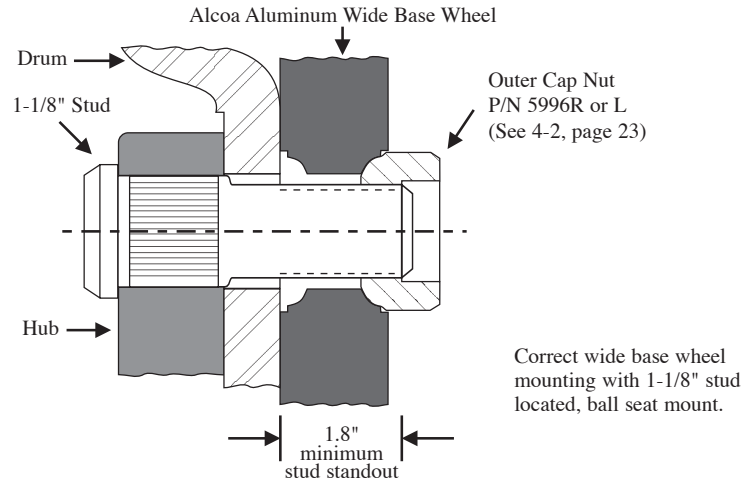

## Dual wheels, stud located, ball seat mounting

Rear wheels are most frequently mounted as duals. Each inner aluminum wheel is attached by 10 inner cap nuts. Alcoa recommends use of inner cap nuts 5978R, 5978L, or 5988R, 5988L (see 4-2, page 23).

Cap nuts recommended by Alcoa are compatible with Alcoa wheels. Hardware of equal dimensions and strength may be used.

## Dualed wheels, stud located, ball seat mounting (continued)

**NOTICE:** Do not exceed maximum wheel load. Customer must compare OEM vehicle load rating to maximum wheel load rating.

Refer to tire manufacturer's recommendation for proper tire pressure. Before mounting the tire, perform a wheel fitment check to insure proper clearance from any obstructions.

**NOTICE:** Check for and replace bent, broken, cracked or damaged studs. When replacing broken studs, always replace the studs on each side of the broken stud. If two or more studs are broken, replace all the studs for that wheel position. Check with the stud manufacturer for regular maintenance and stud replacement practices.

All wheel fastener hardware should be grade 8 or metric conversion 10.9. Follow the hardware manufacturer's recommendations when replacing studs.

Most vehicles have standard length studs (1.31" [1-5/16"] to 1.44" [1-7/16"] stud standout). Some vehicles use studs longer than standard (up to 1.88" [1-7/8"] standout).

When changing types of brake drums be sure to check for excessive stud standout (greater than 1.88" [1-7/8"]). All states and provinces have their own standards for fastener engagement. Most of these consist of at least 1 to 2 threads past full thread engagement. Excessive stud standout may cause the inner cap nut to bottom out on the longer stud, preventing proper seating of the wheel.

Each outer dual wheel is attached by 10 single cap nuts which thread on the inner cap nuts. Use Alcoa outer cap nuts, P/Ns 5996R, 5996L or equivalents. Match mounted dual wheels should be put on the vehicles with the valve stems 180° apart.

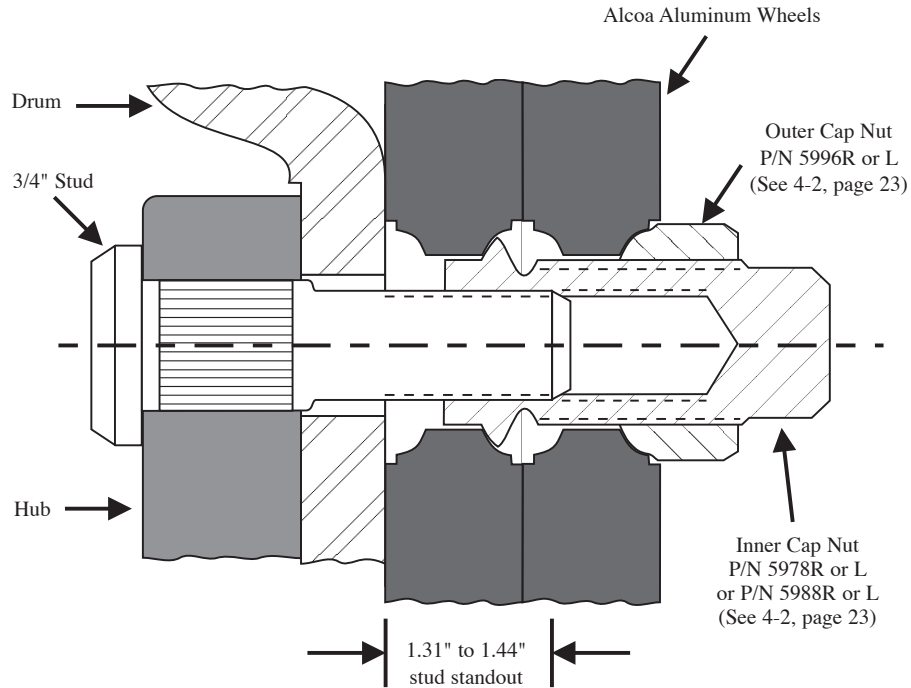

Correct mounting for dual aluminum, stud located / ball seat mount wheels.



**WARNING**

**WARNING** Incorrect inner cap nuts used with dualed aluminum wheels can bottom out on the unthreaded portion of the stud before the wheels are properly seated.

Improperly seated wheels can run loose, cause stud breakage and disengage from the vehicle which can cause serious injury or death. Loose running wheels can lead to stud breakage.

Use only cap nut 5978R or L, 5988R or L, or their equivalent when mounting dual aluminum wheels.

On occasion Alcoa aluminum truck wheels are operated dualed with a steel inner wheel. When this application occurs it is recommended to use a high temperature nylon spacer, because of corrosion issues. In the event a steel inner wheel is used, extreme care must be exercised to properly seat it to the hub or drum prior to mounting the outer aluminum wheel. Selection of an inner cap nut capable of fixing the steel inner wheel and providing adequate external thread length to secure the outer aluminum dualed wheel is critical to a safe assembly. Alcoa recommends the use of inner cap nuts 7896R and L (Grade 8), or equivalent, for this purpose.



Dual wheels, steel inner / aluminum outer stud located ball seat mounting (continued)

4-7

**NOTICE:** Do not exceed maximum wheel load. Customer must compare OEM vehicle load rating to maximum wheel load rating.

Refer to tire manufacturer's recommendation for proper tire pressure. Before mounting the tire, perform a wheel fitment check to insure proper clearance from any obstructions.

**NOTICE:** Check for and replace bent, broken, cracked or damaged studs. When replacing broken studs, always replace the studs on each side of the broken stud. If two or more studs are broken, replace all the studs for that wheel position. Check with the stud manufacturer for regular maintenance and stud replacement practices.

All wheel fastener hardware should be grade 8 or metric conversion 10.9. Follow the hardware manufacturer's recommendations when replacing studs.

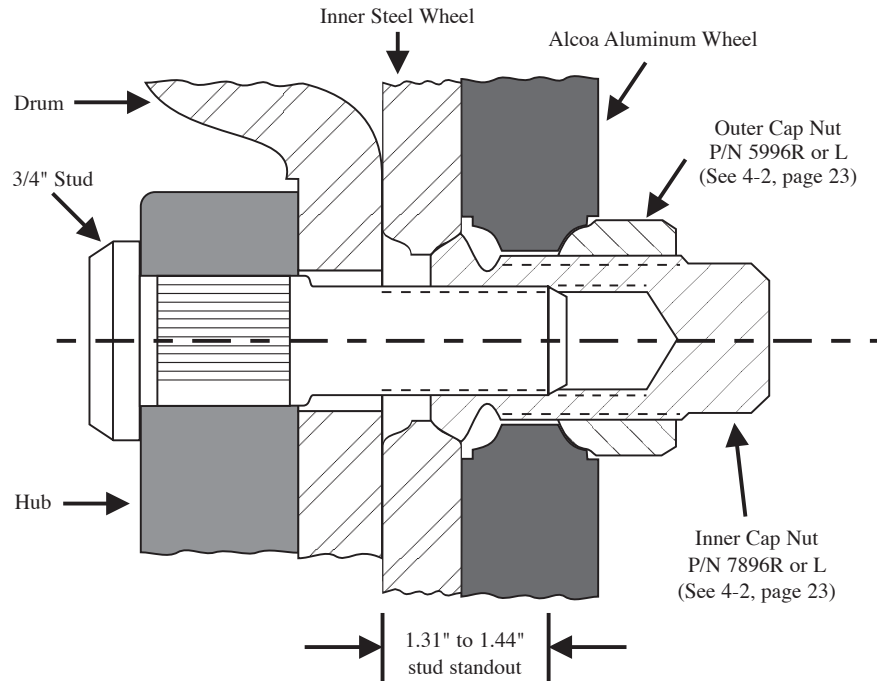

Correct dual mounting for steel inner/aluminum outer stud located ball seat mount.



**WARNING**

**WARNING** Incorrect inner cap nuts used with steel wheels can bottom out on the unthreaded portion of the stud before the wheels are properly seated.

Improperly seated wheels can run loose, cause stud breakage and disengage from the vehicle which can lead to serious injury or death. Loose running wheels can lead to stud breakage.

Use only cap nut 7896R or L or its equivalent when mounting steel inner duals.



**WARNING**

**WARNING** Inadequate wheel support surface can lead to stud hole-to-stud hole fracture resulting in separation of the outer disc and rim from the vehicle.

Separation of the wheel from the vehicle can cause serious injury or death.

Alcoa aluminum wheels with 11-1/4" diameter bolt circle require a support surface at least 13-3/16" in diameter. Check the outer support surface of the inner steel wheel for flatness and adequate diameter before installing the outer wheel. When the wheels are serviced, check the mounting surfaces of both wheels for stud hole-to-stud hole cracks. If cracks are found, immediately and permanently remove the wheel from service. For the support surface diameter required by other bolt circle sizes, ask your Alcoa representative.



**WARNING**

**WARNING** Use of two-piece flange nuts on ball seat wheels or ball seat cap nuts on hub piloted wheels is dangerous.

Using the wrong cap nuts can cause loss of torque, broken studs and cracked wheels, conditions which can lead to serious injury or death.

Use only hardware designed specifically for each wheel type. See Section 4-2 pg. 23 for proper hardware assemblies.

## Tightening stud located, ball seat cap nuts

4-8

Cap nuts must be kept tight, and studs and nuts should be checked frequently. Nuts should be retorqued if necessary. At tire changes, nuts and studs should be inspected for cracks and stripped or damaged threads. After each wheel mounting, cap nut torque should be checked with a torque wrench.

Impact wrenches, if used, should be carefully adjusted to apply torques within the limits recommended. Torquing of cap nuts should be done in recommended sequences.

Some states have laws which dictate full thread engagement or thread engagement past the nut body. Make sure you know the laws for the states in which you operate and comply.



**WARNING**

**WARNING** Lubricants should not be applied to the cap nut seat or to the cap nut-to-wheel contact surface.

Oiled seats can lead to over-torquing which can stretch studs causing failure of studs. Failed studs can cause the wheel to disengage from the vehicle, causing serious injury or death.

Lubricants must be completely removed from the cap nut seats and contact surfaces if applied accidentally.



**WARNING**

**WARNING** Undertorqued cap nuts allow wheels to run loose, pounding out (deforming) the ball seats, fatiguing studs or losing nuts. Overtorquing can stretch studs, causing them to fail.

Both under and overtorquing can lead to wheels coming off, causing serious injury or death.

Check all parts, including wheels, studs and cap nuts. Check mounting faces of wheels, hubs and drums. Check for dirt, corrosion or damage. Remove dirt and rust; replace damaged parts. Follow correct tightening sequences and torque levels.

Continued on next page

## Tightening stud located, ball seat cap nuts



**Inner Cap Nut**  
*Note: The top of the inner cap nut will have thread direction identified on the end of the nut.*

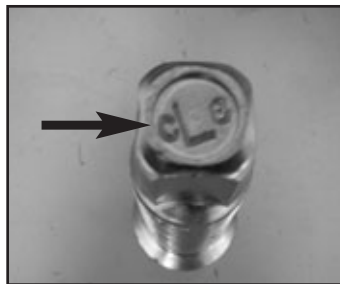

**Inner Cap Nut (left hand threads)**  
*Note: This should have the letter L on the end of the cap nut.*

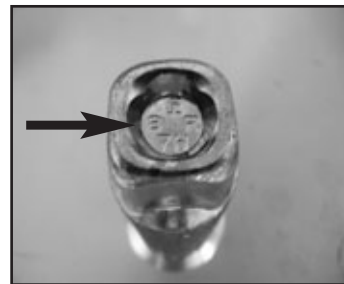

**Inner Cap Nut (right hand threads)**  
*Note: This should have the letter R on the end of the cap nut.*

Tightening stud located, ball seat cap nuts (continued)

Stud Located, Ball Seat Mounting System

It is recommended to torque to between 450 and 500 foot-pounds. If lubricated with motor oil, torque should be between 350 and 400 foot-pounds. Note: when dualing steel wheels with Alcoa aluminum wheels, follow the steel wheel manufacturer's recommendations regarding the proper torque and use of thread lubricants to mount the wheel.



**WARNING** Application of lubricant to the ball seats can cause excessive torque. Over torque can stretch studs, causing them to fail.

Overtorquing can lead to wheel disengagement, causing serious injury or death.

Do not allow oil to contact ball seats or mounting surfaces of the wheel, hub or drum. Do not use aerosol cans for lubrication of stud threads.

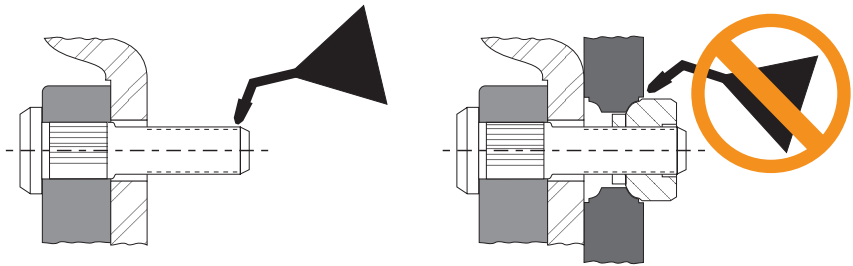

On vehicles equipped to accept wheels manufactured for use with the stud located ball seat mounting system, wheel studs on the right side of the vehicle have right-hand threads and those on the left have left-hand threads. The "R" and "L" on the studs and nuts indicate right and left-hand threads respectively (see Section 4-2) and previous page.

After mounting a wheel over the studs, snug up the cap nuts in the order shown in the illustrations that follow. After all the cap nuts have been snugged, tighten the cap nuts to the recommended torques, following the same tightening sequence.

*NOTICE: In service, stud dimensions and condition may change over time due to environmental conditions, multiple re-installations, improper torquing and other factors. Consult with your hub and stud manufacturer for maintenance and replacement recommendations.*

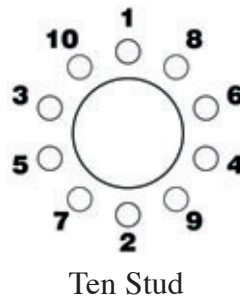
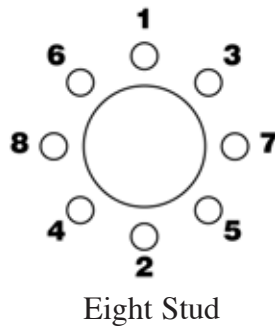
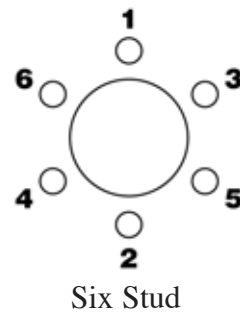
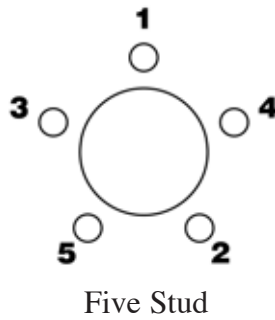

Continued on the next page

## Tightening stud located, ball seat cap nuts (continued)

After 5-50 miles of operation, torque should be rechecked, unless your documented fleet practices determine otherwise. Loosen outer cap nuts on every other stud to check the torque on inner cap nuts, then retorque outer cap nuts. Repeat steps on remaining studs. Check torque frequently from then on. If nuts require frequent tightening, studs break frequently, or wheel nut seats are pounding out, hardware and mounting practices should be reviewed. Note: whenever the outer cap nut is loosened ALWAYS retorque the inner cap nut before retorquing the outer cap nut.

## Hub Piloted Mounting System

### Single, dual and wide base wheels, hub piloted mounting, two-piece flange nuts

Most U.S. manufacturers of highway trucks, tractors and trailers which incorporate the hub piloted wheel mounting system require wheel studs and cap nuts with metric threads. Most frequently these are M22x1.5.

Generally the same diameter stud is used to mount either single or dual wheels.

Studs on both sides of the vehicle are right-hand threads thereby eliminating the need for flange nuts peculiar to either the right or left side of the vehicle. The same flange nut is used to mount dual or single wheels.

Most states have laws which dictate full thread engagement or thread engagement past the nut body. Make sure you know the laws for the states in which you operate and comply.

Note: Some stud located ball seat wheels have the same number of holes and bolt circle diameter as hub piloted wheels. They should not be mixed.

## 4-9

**NOTICE:** Do not exceed maximum wheel load. Customer must compare OEM vehicle load rating to maximum wheel load rating.

Refer to tire manufacturer's recommendation for proper tire pressure. Before mounting the tire, perform a wheel fitment check to insure proper clearance from any obstructions.

**NOTICE:** Check for and replace bent, broken, cracked or damaged studs. When replacing broken studs, always replace the studs on each side of the broken stud. If two or more studs are broken, replace all the studs for that wheel position. Check with the stud manufacturer for regular maintenance and stud replacement practices.

All wheel fastener hardware should be grade 8 or metric conversion 10.9. Follow the hardware manufacturer's recommendations when replacing studs.

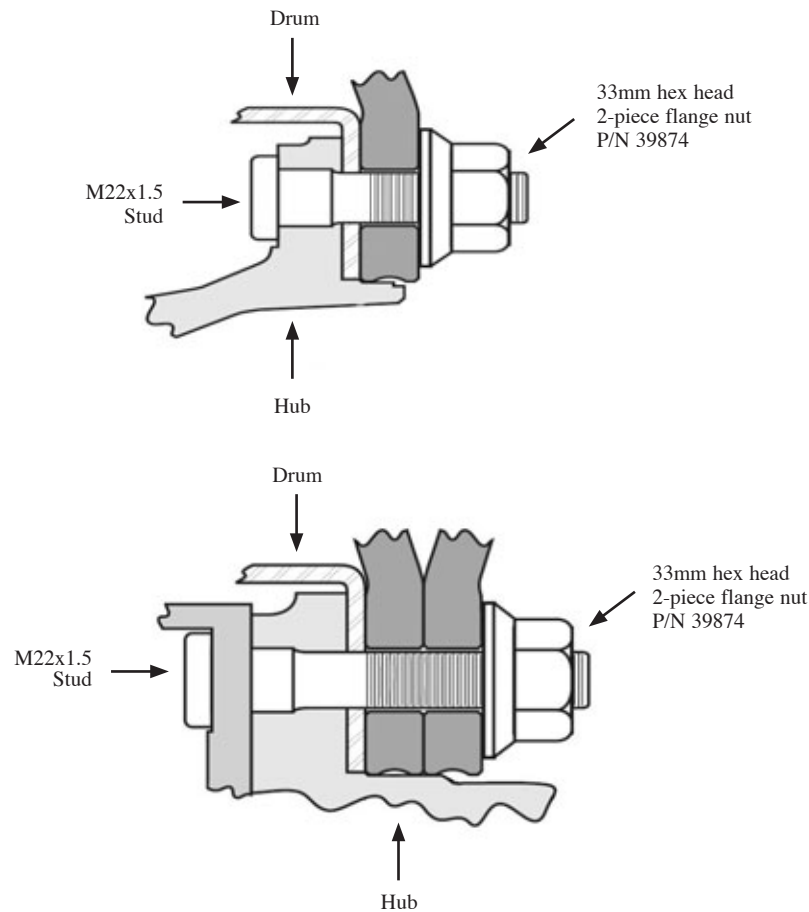

Typical assembly of single and dual wheels of hub piloted type with 33mm hex head two-piece flange nut, Part No. 39874. If hex nuts with greater overall height are used, more stud length is required.

Continued on the next page

## Single, dualed and wide base wheels, hub piloted mounting, two-piece flange nuts (continued)

Hubs designed for steel hub piloted wheels may not have enough pilot length to locate dualed aluminum wheels. Pay close attention to pilot length, particularly when converting from steel to aluminum duals. Measure the hub pilot to make sure the hub has a minimum pilot length of 1.38" or 35mm for dualed wheels.

When mounting painted steel inner dual wheels with outer aluminum wheels, be cautious of excessive paint build-up on the inner steel wheel. Excessive paint can reduce the clamping force and allow the wheels to become loose.

## Two-pieced sleeved flange nuts

Sleeved flange nuts serve two purposes.

1. Increase thread engagement.
2. Reduce indexing of wheels.

When using sleeved flange nuts:

- There are two kinds of sleeved flange nuts - single mount and dual mount, as shown.
- All threads in the sleeve do not need to be engaged with the wheel bolt for proper installation.
- Sleeved flange nut should have enough length to engage both wheels in a dual application. **DO NOT USE** single wheel nuts in a dual wheel application.
- Always use wheels and hardware that are designed for use with sleeved flange nuts.

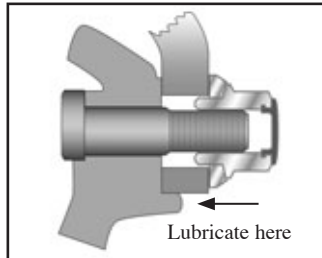

Single mounted wheels require sleeved flange nuts with a short sleeve.

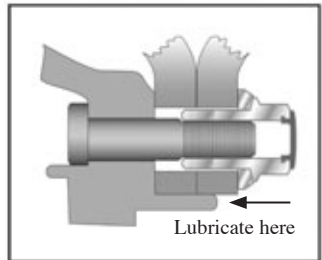

Dual mounted wheels require sleeved flange nuts with long sleeve nuts.

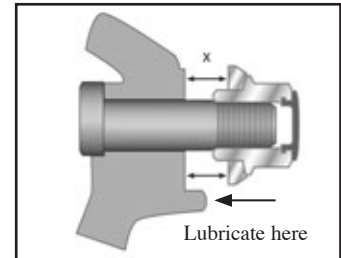

This space (x) must be 2mm less than the thickness of the Alcoa wheel to be accommodated. Determine this space when the nut is bottomed out at the stud without a wheel mounted.

## Tightening hub piloted mounting, two-piece flange nuts

Flange nuts must be kept tight, and studs and nuts should be checked frequently. At tire changes, nuts and studs should be inspected to be sure they are in good condition. If nuts require frequent tightening or studs break frequently, hardware and mounting practices should be reviewed.

Impact wrenches, if used, should be carefully adjusted to apply torques within the limits recommended. Torquing of flange nuts should be done in recommended sequences.

## 4-10



**WARNING**

**WARNING** Under-torqued flange nuts can allow wheels to run loose and fatigue studs or lose nuts. Overtorquing can stretch studs, causing them to fail.

Both under and overtorquing can lead to wheel disengagement, causing serious injury or death.

Check all parts including wheels, studs and flange nuts. Check mounting faces of wheels, hubs and drums. Check for dirt, corrosion or damage. Remove dirt and rust; replace damaged parts. Follow correct tightening sequences and torque levels.

Two-piece flange nuts with a 33mm hex head design (see Section 4-2), used with hub piloted wheels should be tightened to a torque of 450 to 500 foot-pounds. Two-piece flange nuts with 1-1/2" hex head design and other designs have different torque requirements. Contact the manufacturer for the proper torque values. See section 5-2.

Wheel studs on both the right and left side hubs of vehicles utilizing the hub piloted wheel system have right-hand threads.

Prior to mounting hub piloted wheels, generously coat the wheel pilot or hub pads with a non-water-based lubricant to minimize corrosion product build-up between the wheel and hub pilot. Excessive corrosion build-up between the wheel and hub pilots can make wheel removal difficult. Do not lubricate the face of the wheel, hub or brake drum (see illustration on the next page).

Continued on the next page



**Tightening  
hub-piloted  
mounting,  
two-piece  
flange nuts  
(continued)**

Lubricate the hub pads or the wheel hub bore generously with a non-water-based lubricant.

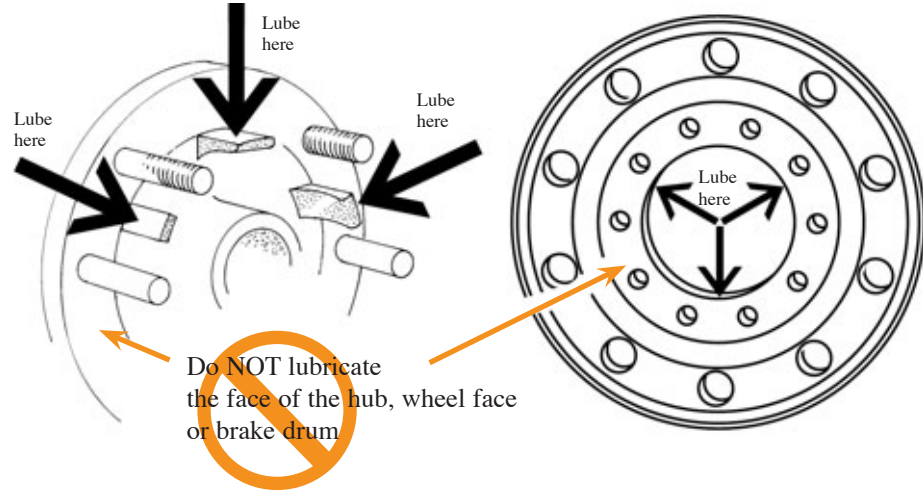

Before installing two-piece flange nuts, lightly lubricate the stud threads and the contact surfaces between the cap nut and the washer, as illustrated below, with motor oil. This will minimize corrosion between the mating surfaces. Lubrication is not necessary with new hardware.

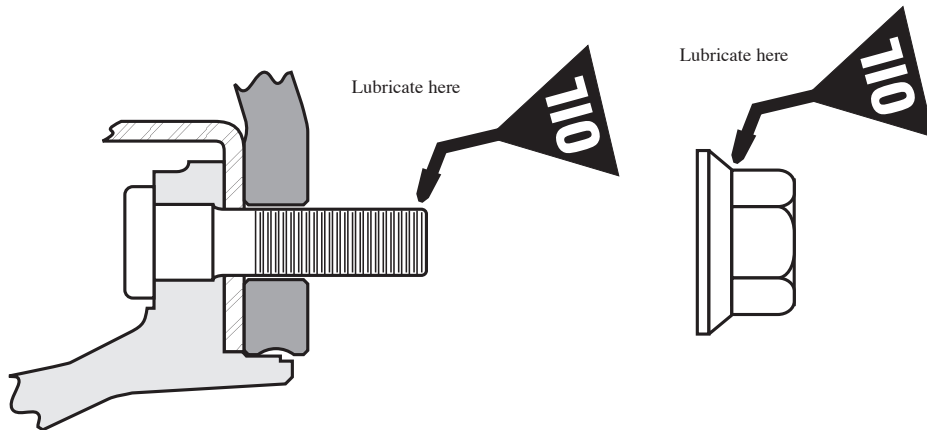

Position one of the hub's pilot pads at the twelve o'clock position. After positioning wheels on the pilot pads, hand tighten all two-piece flange nuts, then tighten to the recommended torque, following the proper sequence shown below for your type wheel. After 5-50 miles of operation, torque should be rechecked, unless your documented fleet practices determine otherwise. Check torque frequently from then on. If nuts require frequent tightening, studs break frequently, or wheel bolt holes are pounding out, hardware and mounting practices should be reviewed.

*NOTICE: In service, stud dimensions and condition may change over time due to environmental conditions, multiple re-installations, improper torquing and other factors. Consult with your hub and stud manufacturer for maintenance and replacement recommendations.*

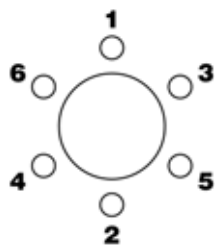

Six Stud

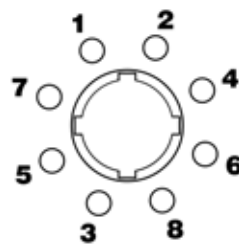

Eight Stud

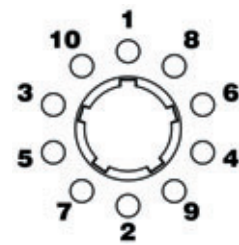

Ten Stud

## Incorrect assemblies

### 4-11

The following are examples of incorrect wheel assemblies.



**WARNING**

**WARNING** Use of two-piece flange nuts on ball seat wheels, ball seat cap nuts on hub piloted wheels or single-piece flange nuts in place of 2-piece flange nuts is dangerous.

Using the wrong wheel nuts can cause loss of torque, broken studs and cracked wheels, conditions which can lead to serious injury or death.

Use only hardware designed specifically for each wheel type. See Section 4-2 pg. 23 for proper hardware assemblies.

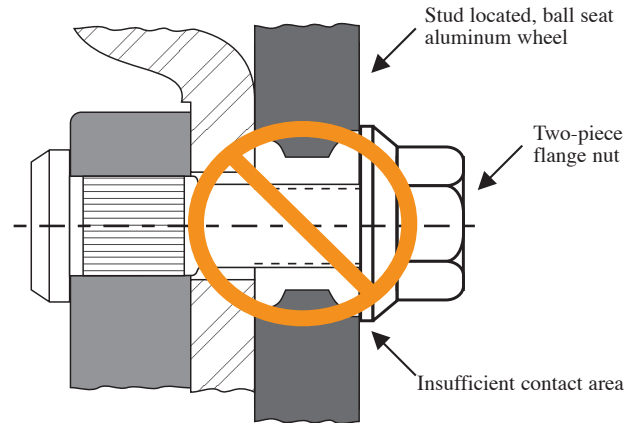

Do not use two-piece flange nuts with stud located ball seat wheels.

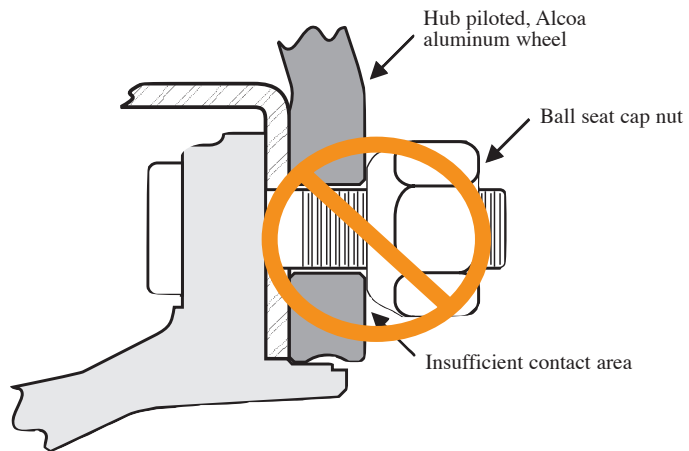

Incorrect use of ball seat cap nut on hub piloted system.  
Do not use ball seat cap nuts with hub piloted wheels.

**NOTICE:** All of the different variations of mounting wheels incorrectly on hubs.



Incorrect use of ball seat wheels on hub piloted system. Do not use ball seat wheels as inner and outer duals with a hub piloted wheel system.



Incorrect use of ball seat wheel on hub piloted system. Do not use ball seat wheels as inner dual with a hub piloted wheel system.



Incorrect use of ball seat wheel on hub piloted system. Do not use ball seat wheels as outer duals with a hub piloted mounting system.



Incorrect use of a hub-piloted wheel as an inner. Do not use hub-piloted wheels with stud-piloted mounting systems. Note the lack of contact between duals.

# 5 Proper Torque, Wheel Identification and Valves

## Avoid abuse

Abuse can shorten the life of a wheel. Lack of care in changing a tire, heavy pounding of the wheel rim, overloading, exposure to excessive heat or hitting curbs at high speed or a sharp angle can damage wheels.

## 5-1

Do not overinflate. Use the tire manufacturer's recommended pressure, but under no circumstances exceed cold tire pressures roll stamped on the wheel. Before mounting the tire, perform a wheel fitment check to insure proper clearance from any obstructions.

## Keep wheel nuts tight

Wheel cap nuts must be kept tight (see Section 4-8). When checking the cap nuts on dual disc wheels utilizing the stud located ball seat mounting system, loosen every other outer cap nut and then check the torque of the inner cap nuts. Retorque the loosened outer cap nuts. Repeat procedure with the rest of the nuts. Check all cap nuts for proper torque after the first use or any removal. Inspect wheels (see Section 2) and check wheel nuts during service stops. Dirt streaks from cap nuts may indicate looseness.

## 5-2

Flange nuts must be kept tight, and studs and nuts should be checked frequently. At tire changes, nuts and studs should be inspected to be sure they are in good condition. If nuts require frequent tightening or studs break frequently, hardware and mounting practices should be reviewed.

For proper nut torque, refer to the chart below:

Mount Type	Nut Thread	Torque Level Ft-Lb Lubricated*	Torque Level Ft-Lb Dry*
Hub piloted using two-piece flange nut	11/16" - 16	300-400	
	7/8" - 14	350-400	
	M20 x 1.5	280-330	
	M22 x 1.5	450-500	
Stud piloted, double cap nut standard type (7/8" radius)	3/4" - 16		450-500
	1-1/8" - 16		450-500
Stud piloted, double cap nut heavy duty type (1-3/16" radius)	15/16" - 12		750-900
	1-1/8" - 16		750-900
	1-5/16" - 12		750-900

\*For nuts used on hub piloted wheels, apply two drops of motor oil to the point between the nut and flange and two drops to the first two or three threads at the tip of each stud (see Section 4-10).

For nuts used on stud piloted wheels, apply two drops of motor oil to the first two or three threads at the tip of each stud only (see Section 4-8).

### NOTE:

1. If using specialty fasteners (cap nuts), consult the manufacturer for recommended torque values.
2. Tightening wheel nuts to their specified torque is extremely important. Undertightening results in loose wheels which can damage wheels, studs and hubs, and can result in wheel loss. Overtightening can damage studs, nuts and wheels, and results in loose wheels as well.
3. All torque wrenches, air wrenches and any other tools should be calibrated periodically to ensure the proper torque is applied.

## Balance weights

Balance weights for Alcoa wheels are available from your Alcoa Wheel Distributor. With radial tires it may be necessary to temporarily reduce the tire pressure when installing clip-on weights to allow clearance of the weight clamp over the rim flange. Use of coated balance weights is recommended to avoid staining and corrosion of the aluminum wheel surface.

### 5-3

Excessive rim flange wear (see Section 2-12) could dictate the use of “stick-on” or adhesive wheel weights if there is inadequate rim to properly hold a clip-on style weight.

Improperly installed weights could “fly off” during use and damage the vehicle or cause personal injury. Always follow the recommended procedures in this manual or from the wheel weight manufacturer.

Adhesive weights should be applied only to a clean surface on the brake side of the wheel rim. These weights should be installed only in a location where they will not contact the brake components during vehicle operation.

#### POSTIONING:

Both sides of the wheel have a designed area where the adhesive weights must be applied.

For wheels with the 2nd generation of Alcoa wheel rim flange design only, the weights should always be applied against the small hump / wedge i.e. as close as possible to the rim flange.

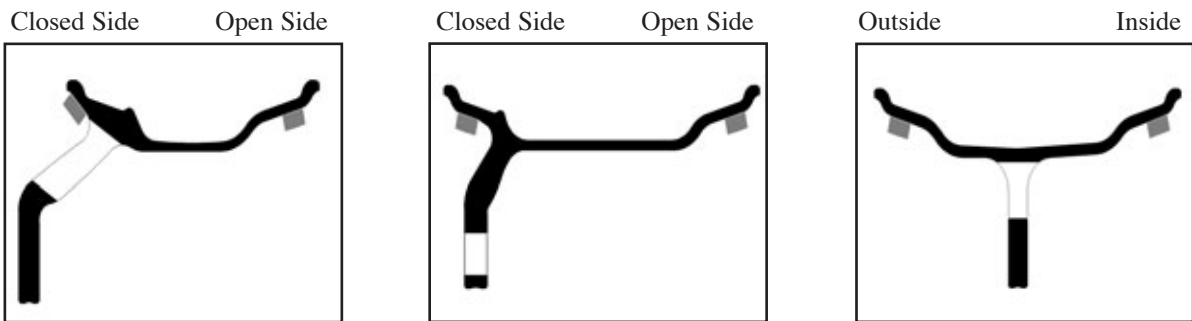

## Owner/in-service identification

Some fleets wish to specially identify wheels as to OWNERSHIP and IN-SERVICE dates. Alcoa permits the practice of permanently stamping wheels with the date they are first placed into service.

### 5-4

1. Use “Lo-Stress” stamps or equivalent.
2. Location of stamped areas on outside disc should be in space outward from a line between hand hole centers and a minimum of one inch from the periphery of any hand hole.
3. Location of stamped identification on inside of wheel should be as close to the factory identification stamping as possible.

Note: Use of an impression stamp on Dura-Bright® surface treated wheels can affect the appearance and performance of the Dura-Bright® surface treatment local to the stamp.

## Valves

Alcoa drop center wheels for tubeless tires come from the factory with air valves installed. If it becomes necessary to replace an air valve, install it using 9 to 11 ft-lbs, 12 to 15 Nm, 110 to 130 in-lbs of torque.

### 5-5

Replacement valves may be obtained from your authorized Alcoa Wheel Distributor. Always use silicone O-rings or grommets – not rubber – when reinstalling valve stems. Metal valve stem caps are recommended instead of plastic. It is recommended that valve stems with O-rings or grommets be replaced at every tire change.

When replacing valve stems, it is recommended to lubricate the threads and O-ring or grommet with a non-water based tire lubricant.

When metal valve stem extensions are used, it is recommended that valve stem stabilizers be used or use a plastic valve stem extension.

# Identification

## 5-6

### Alcoa Wheel Identification

Since 1977, all Alcoa aluminum disc wheels have been identified with a stamp that shows the wheel load rating, maximum inflation pressure, date of manufacture, part number, wheel description and DOT marking designation.

Prior to June 1996, all Alcoa heavy duty truck wheels had the Alcoa identification symbol  on the outside of the disc near the hand hole in line with the valve location. This marking was phased out on heavy duty truck wheels manufactured after June 1996.

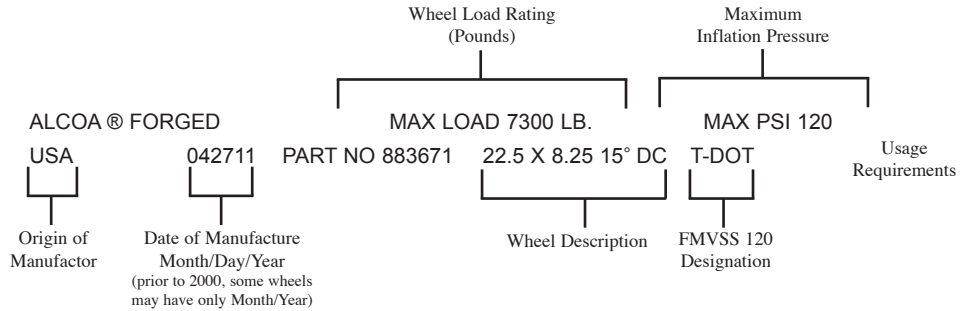

All Dura-Bright® surface treated wheels are designated by the letters “DB” following the part number such as 883671DB.

Note: Dura-Bright® wheels produced after November 2002 have Alcoa wheel part numbers ending with “DB” (earlier wheels have part numbers ending in a 4 or 7) with bead seat diameters measured in 0.5-inch increments. Not all Alcoa wheels are available with the Dura-Bright® surface treatment.

All Dura-Flange® wheels are designated by the letters “DF” following the part number such as 883677DF.

All Dura-Bright® / Dura-Flange® wheels are designated by the letters “DD” following the part number such as 883673DD.

As of January 2009 Alcoa introduced a new logo label.

Usage requirements include warnings, spindle recommendations, recommended torque levers and customer service number.



# 6

# OSHA Regulations

## OSHA Regulations

(29 C.F.R. Section 1910.177)

## 6-1

### (a) Scope

---

- (1) This section applies to the servicing of multi-piece and single piece rim wheels used on large vehicles such as trucks, tractors, trailers, buses and off-road machines. It does not apply to the servicing of rim wheels used on automobiles, or on pickup trucks and vans utilizing automobile tires or truck tires designated "LT".
- (2) This section does not apply to employers and places of employment regulated under the Longshoring Standards, 29 CFR part 1918; Construction Safety Standards, 29 CFR part 1926; or Agriculture Standards, 29 CFR part 1928.
- (3) All provisions of this section apply to the servicing of both single piece rim wheels and multi-piece rim wheels unless designated otherwise.

### (b) Definitions

---

Barrier means a fence, wall or other structure or object placed between a single piece rim wheel and an employee during tire inflation, to contain the rim wheel components in the event of the sudden release of the contained air of the single piece rim wheel.

Charts means the U.S. Department of Labor, Occupational Safety and Health Administration publications entitled "Demounting and Mounting Procedures for Truck/Bus Tires" and "Multi-Piece Rim Wheel Matching Chart," the National Highway Traffic Safety Administration (NHTSA) publications entitled "Demounting and Mounting Procedures for Truck/Bus Tires" and "Multi-Piece Rim Wheel Matching Chart," or any other poster which contains at least the same instructions, safety precautions and other information contained in the charts that is applicable to the types of wheels being serviced.

Installing a rim wheel means the transfer and attachment of an assembled rim wheel onto a vehicle axle hub. "Removing" means the opposite of installing.

Mounting a tire means the assembly or putting together of the wheel and tire components to form a rim wheel, including inflation. "Demounting" means the opposite of mounting.

Multi-piece rim wheel means the assemblage of a multi-piece wheel with the tire tube and other components.

Multi-piece wheel means a vehicle wheel consisting of two or more parts, one of which is a side or locking ring designed to hold the tire on the wheel by interlocking components when the tire is inflated.

Restraining device means an apparatus such as a cage, rack, assemblage of bars and other components that will constrain all rim wheel components during an explosive separation of a multi-piece rim wheel, or during the sudden release of the contained air of a single piece rim wheel.

Rim manual means a publication containing instructions from the manufacturer or other qualified organization for correct mounting, demounting, maintenance, and safety precautions peculiar to the type of wheel being serviced.

Rim wheel means an assemblage of tire, tube and liner (where appropriate), and wheel components.

Service or servicing means the mounting and demounting of rim wheels, and related activities such as inflating, deflating, installing, removing, and handling.

Service area means that part of an employer's premises used for the servicing of rim wheels, or any other place where an employee services rim wheels.

Single piece rim wheel means the assemblage of single piece rim wheel with the tire and other components.

Single piece wheel means a vehicle wheel consisting of one part, designed to hold the tire on the wheel when the tire is inflated.

Trajectory means any potential path or route that a rim wheel component may travel during an explosive separation, or the sudden release of the pressurized air, or an area at which an airblast from a single piece rim wheel may be released. The trajectory may deviate from paths which are perpendicular to the assembled position of the rim wheel at the time of separation or explosion. (See Appendix A for examples of trajectories.)

Wheel means that portion of a rim wheel which provides the method of attachment of the assembly to the axle of a vehicle and also provides the means to contain the inflated portion of the assembly (i.e., the tire and/or tube).

### (c) Employee Training

---

- (1) The employer shall provide a program to train all employees who service rim wheels in the hazards involved in servicing those rim wheels and the safety procedures to be followed.
  - (i) The employer shall assure that no employee services any rim wheel unless the employee has been trained and instructed in correct procedures of servicing the type of wheel being serviced, and in the safe operating procedures described in paragraphs (f) and (g) of this section.
  - (ii) Information to be used in the training program shall include, at a minimum, the applicable data contained in the charts (rim manuals) and the contents of this standard.
  - (iii) Where an employer knows or has reason to believe that any of his employees is unable to read and understand the charts or rim manual, the employer shall assure that the employee is instructed concerning the contents of the charts and rim manual in a manner which the employee is able to understand.
- (2) The employer shall assure that each employee demonstrates and maintains the ability to service rim wheels safely, including performance of the following tasks:
  - (i) Demounting of tires (including deflation);
  - (ii) Inspection and identification of the rim wheel components;
  - (iii) Mounting of tires (including inflation with a restraining device or other safeguard required by this section);
  - (iv) Use of the restraining device or barrier, and other equipment required by this section;
  - (v) Handling of rim wheels;
  - (vi) Inflation of the tire when a single piece rim wheel is mounted on a vehicle;
  - (vii) An understanding of the necessity of standing outside the trajectory both during inflation of the tire and during inspection of the rim wheel following inflation; and
  - (viii) Installation and removal of rim wheels.
- (3) The employer shall evaluate each employee's ability to perform these tasks and to service rim wheels safely, and shall provide additional training as necessary to assure that each employee maintains his or her proficiency.

### (d) Tire Servicing Equipment

---

- (1) The employer shall furnish a restraining device for inflating tires on multi-piece wheels.
- (2) The employer shall provide a restraining device or barrier for inflating tires on single piece wheels unless the rim wheel will be bolted onto a vehicle during inflation.
- (3) Restraining devices and barriers shall comply with the following requirements:
  - (i) Each restraining device or barrier shall have the capacity to withstand the maximum force that would be transferred to it during a rim wheel separation occurring at 150 percent of the maximum tire specification pressure for the type of rim wheel being serviced.
  - (ii) Restraining devices and barriers shall be capable of preventing the rim wheel components from being thrown outside or beyond the device or barrier for any rim wheel positioned within or behind the device;
  - (iii) Restraining devices and barriers shall be visually inspected prior to each day's use and after any separation of the rim wheel components or sudden release of contained air. Any restraining device or barrier exhibiting damage such as the following defects shall be immediately removed from service:
    - (A) Cracks at welds;
    - (B) Cracked or broken components;
    - (C) Bent or sprung components caused by mishandling, abuse, tire explosion or rim wheel separation;

# OSHA Regulations (continued)

- (D) Pitting of components due to corrosion; or
  - (E) Other structural damage which would decrease its effectiveness.
- (iv) Restraining devices or barriers removed from service shall not be returned to service until they are repaired and reinspected. Restraining devices or barriers requiring structural repair such as component replacement or rewelding shall not be returned to service until they are certified by either the manufacturer or a Registered Professional Engineer as meeting the strength requirements of paragraph (d)(3)(i) of this section.
- (4) The employer shall furnish and assure that an air line assembly consisting of the following components be used for inflating tires:
    - (i) A clip-on chuck;
    - (ii) An in-line valve with a pressure gauge or a presettable regulator; and
    - (iii) A sufficient length of hose between the clip-on chuck and the in-line valve (if one is used) to allow the employee to stand outside the trajectory.
  - (5) Current charts or rim manuals containing instructions for the type of wheels being serviced shall be available in the service area.
  - (6) The employer shall furnish and assure that only tools recommended in the rim manual for the type of wheel being serviced are used to service rim wheels.

## (e) Wheel Component Acceptability

---

- (1) Multi-piece wheel components shall not be interchanged except as provided in the charts or in the applicable rim manual.
- (2) Multi-piece wheel components and single piece wheels shall be inspected prior to assembly. Any wheel or wheel component which is bent out of shape, pitted from corrosion, broken, or cracked shall not be used and shall be marked or tagged unserviceable and removed from the service area. Damaged or leaky valves shall be replaced.
- (3) Rim flanges, rim gutters, rings, bead seating surfaces and the bead areas of tires shall be free of any dirt, surface rust, scale or loose or flaked rubber build-up prior to mounting and inflation.
- (4) The size (bead diameter and tire/wheel widths) and type of both the tire and the wheel shall be checked for compatibility prior to assembly of the rim wheel.

## (f) Safe Operating Procedure - Multi-Piece Rim Wheels

---

The employer shall establish a safe operating procedure for servicing multi-piece rim wheels and shall assure that employees are instructed in and follow that procedure. The procedure shall include at least the following elements:

- (1) Tires shall be completely deflated before demounting by removal of the valve core.
- (2) Tires shall be completely deflated by removing the valve core before a rim wheel is removed from the axle in either of the following situations:
  - (i) When the tire has been driven underinflated at 80% or less of its recommended pressure, or
  - (ii) When there is obvious or suspected damage to the tire or wheel components.
- (3) Rubber lubricant shall be applied to bead and rim mating surfaces during assembly of the wheel and inflation of the tire, unless the tire or wheel manufacturer recommends against it.
- (4) If a tire on a vehicle is underinflated but has more than 80% of the recommended pressure, the tire may be inflated while the rim wheel is on the vehicle provided remote control inflation equipment is used, and no employees remain in the trajectory during inflation.
- (5) Tires shall be inflated outside a restraining device only to a pressure sufficient to force the tire bead onto the rim ledge and create an airtight seal with the tire and bead.
- (6) Whenever a rim wheel is in a restraining device the employee shall not rest or lean any part of his body or equipment on or against the restraining device.
- (7) After tire inflation, the tire and wheel components shall be inspected while still within the restraining device to make sure that they are properly seated and locked. If further adjustment to the tire or wheel components is necessary, the tire shall be deflated by removal of the valve core before the adjustment is made.

OSHA  
Regulations  
(continued)

- (8) No attempt shall be made to correct the seating of side and lock rings by hammering, striking or forcing the components while the tire is pressurized.
- (9) Cracked, broken, bent or otherwise damaged rim components shall not be reworked, welded, brazed, or otherwise heated.
- (10) Whenever multi-piece rim wheels are being handled, employees shall stay out of the trajectory unless the employer can demonstrate that performance of the servicing makes the employee's presence in the trajectory necessary.
- (11) No heat shall be applied to a multi-piece wheel or wheel component.

**(g) Safe Operating Procedure - Single Piece Rim Wheels**

---

The employer shall establish a safe operating procedure for servicing single piece rim wheels and shall assure that employees are instructed in and follow that procedure. The procedure shall include at least the following elements:

- (1) Tires shall be completely deflated by removal of the valve core before demounting.
- (2) Mounting and demounting of the tire shall be done only from the narrow ledge side of the wheel. Care shall be taken to avoid damaging the tire beads while mounting tires on wheels. Tires shall be mounted only on compatible wheels of matching bead diameter and width.
- (3) Nonflammable rubber lubricant shall be applied to bead and wheel mating surfaces before assembly of the rim wheel, unless the tire or wheel manufacturer recommends against the use of any rubber lubricant.
- (4) If a tire changing machine is used, the tire shall be inflated only to the minimum pressure necessary to force the tire bead onto the rim ledge while on the tire changing machine.
- (5) If a bead expander is used, it shall be removed before the valve core is installed and as soon as the rim wheel becomes airtight (the tire bead slips onto the bead seat).
- (6) Tires may be inflated only when contained within a restraining device, positioned behind a barrier or bolted on the vehicle with the lug nuts fully tightened.
- (7) Tires shall not be inflated when any flat, solid surface is in the trajectory and within one foot of the sidewall.
- (8) Employees shall stay out of the trajectory when inflating a tire.
- (9) Tires shall not be inflated to more than the inflation pressure stamped in the sidewall unless a higher pressure is recommended by the manufacturer.
- (10) Tires shall not be inflated above the maximum pressure recommended by the manufacturer to seat the tire bead firmly against the rim flange.
- (11) No heat shall be applied to a single piece wheel.
- (12) Cracked, broken, bent, or otherwise damaged wheels shall not be reworked, welded, brazed, or otherwise heated.

[39 FR 23502, June 27, 1974, as amended at 52 FR 36026, Sept. 25, 1987; 53 FR 34736, Sept. 8, 1988]

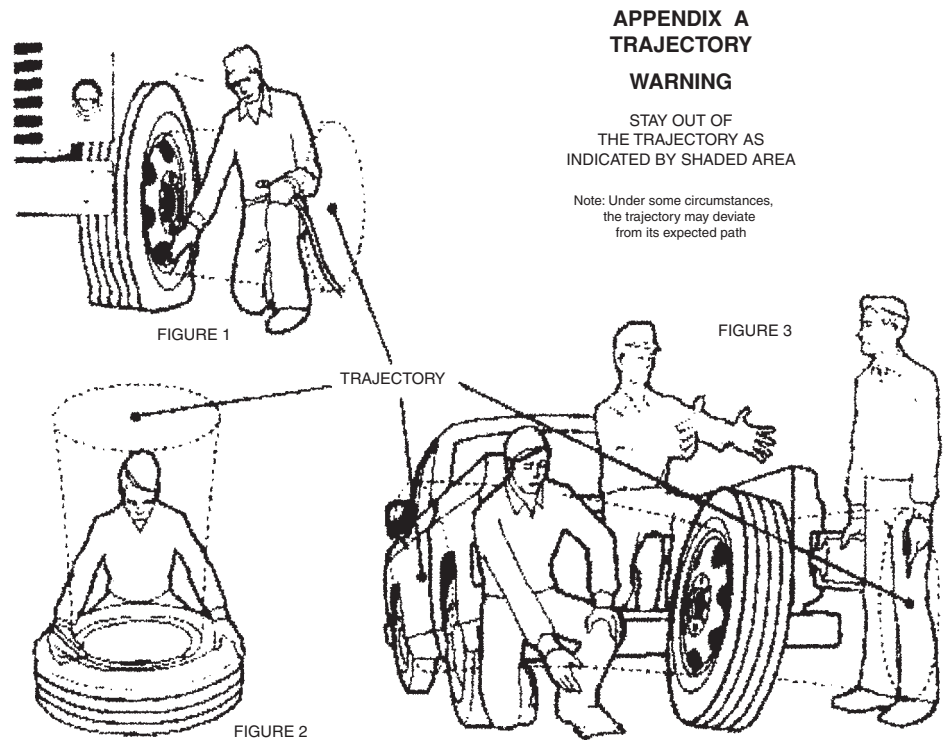

Appendix B - Ordering Information for NHTSA Charts

OSHA has printed two charts entitled "Demounting and Mounting Procedures for Truck/Bus Tires" and "Multi-piece Rim Matching Chart," as part of a continuing campaign to reduce accidents among employees who service large vehicle rim wheels.

Reprints of the charts are available through the Occupational Safety and Health Administration (OSHA) Area and Regional Offices. The address and telephone number of the nearest OSHA office can be obtained by looking in the local telephone directory under U.S. Government, U.S. Department of Labor, Occupational Safety and Health Administration.

Single copies are available without charge.

Individuals, establishments and other organizations desiring single or multiple copies of these charts may order them from the OSHA Publications Office, U.S. Department of Labor, Room N-3101, Washington, DC 20210, Telephone (202) 219-4667.

[49 FR 4350, Feb. 3, 1984, as amended at 52 FR 36026, Sept. 25, 1987; 53 FR 34737, Sept. 8, 1988; 61 FR 9239, Mar. 7, 1996]



# 7

# Glossary of Common Terms

## Glossary of Common Terms

### 7-1

AIR CHAMBER - The area in a mounted tire and rim assembly that contains the air.

BEAD SEAT - The tire seating surface of the rim.

BOLT CIRCLE - The circle defined by the centers of the bolt holes (stud holes) of a wheel, dimensions stated in diameter inches or millimeters.

BOLT HOLE - A hole in a disc wheel for attachment fasteners.

BORE - See "CENTER HOLE."

CENTER BORE - See "CENTER HOLE."

DISC - The center member of a disc wheel.

DISC FACE - The flat central portion of a disc wheel in which the bolt holes are located and which contacts the drum, hub or mating wheel.

DISC WHEEL - A rim combined with a center disc which has bolt holes for attaching to a vehicle.

DISC WHEEL HALF DUAL SPACING - The distance from the outside disc face (surface between the wheels as a dual assembly) to the center of the rim.

DOUBLE CAP NUTS - Two wheel nuts used in stud-piloted wheel systems. They include inner cap nuts used to fasten inner wheels to a vehicle and outer cap nuts used to fasten single wheels and outer wheels to a vehicle. These nuts have both right and left hand threads and have ball seats that fit into the wheel ball, and ball seat bolt holes to center and clamp the wheels on the hub.

DROP CENTER - The well or center portion of the wheel rim.

DUAL WHEEL - Any wheel that can be mated disc side to disc side with another wheel resulting in an inner and outer dual wheel assembly.

FLANGE NUT - A nut with a flat face or flange that bears against the wheel; can be one-piece or multi-piece construction.

FLAT BASE WHEEL - A multi-piece wheel with a removable side ring.

FOOT-POUNDS - The measure of the amount of torque applied to a cap nut or other part. May be measured with a torque wrench.

GUTTER FLANGE - A groove which supports the removable portion of a multi-piece wheel.

CENTER HOLE - (Hub Hole, Hub Bore, Center Bore, Bore) The large hole in the middle of a disc wheel.

HUB PILOTED MOUNTING - A wheel mounting system in which location of the wheel is accomplished by positioning the wheel center hole on a machined pilot, (continuous or interrupted) on the hub. Fastening is accomplished by flange nuts bearing against the flat face of the wheel disc.

HUB PILOTS - Pads on the hub to locate the center hole of a hub-piloted wheel.

in. - Abbreviation for inches.

INNER CAP NUT - The ball seat nut used to install the inner stud-piloted dual wheel to a vehicle. (see Double Cap Nut)

INSET - The distance from the wheel mounting surface to the rim centerline when the centerline is placed inboard of the mounting surface.

kg - Abbreviation for kilogram (weight measurement), equal to 1000 grams.

kPa - Abbreviation for kilo Pascals (pressure measurement).

## Glossary of Common Terms (continued)

LOCK RING - The third piece of a 3-piece rim assembly which locks the side ring to the rim base.

MAXIMUM INFLATION - The highest amount of air pressure allowed, measured at normal ambient temperatures.

mm - Abbreviation for millimeters.

MULTI-PIECE WHEEL - A wheel assembly in which the rim portion of the wheel consists of two or more separate parts.

N-m - Abbreviation for Newton meters

OFFSET - See "OUTSET."

OPEN SIDE - The side of the wheel opposite the disc face.

OSHA - Abbreviation for the U.S. Department of Labor, Occupational Safety and Health Administration.

OUTER CAP NUT - The ball seat nut used to install the outer wheel of a stud-piloted dual assembly or a single stud-piloted wheel to a vehicle. The outer nut screws onto the inner cap in a dual assembly. (See Double Cap Nut.)

OUTSET - The distance from the mounting surface of the wheel to the rim centerline when the rim centerline is mounted outboard of the hub face. This dimension is the same as the 1/2 DUAL SPACING dimension.

PILOT PAD - See "HUB PILOTS".

PSI - Abbreviation for pounds per square inch.

REVERSIBLE - Term applied to a disc wheel which can be reversed on the hub without changing the position of the tire centerline.

RIM - That portion of the wheel which supports the tire.

RIM CENTERLINE - A line to the radial axis of the wheel running through the mid point between the rim flanges.

RIM FLANGE - The edge of a rim that has a larger diameter than the tire bead designed to support the tire.

SIDE RING - One removable component of a multi-piece rim assembly which provides lateral support for one tire bead.

SINGLE CAP NUT - A cap nut used to secure single wheels or outer dual wheels.

STUD - A threaded bolt that is used with wheel nuts to fasten wheels or rims to a vehicle.

STUD-PILOTED MOUNTING - A wheel mounting system in which location and fastening of the wheel are both accomplished by nuts which fit corresponding studs at each wheel bolt hole.

TIRE BEAD - That surface of the tire which contacts the angled surface of the wheel rim.

TORQUE - The measure of tightness.

WHEEL MOUNTING FACE - See "DISC FACE".

wt. - Abbreviation for weight.

7-2

Minimum dual spacing measurement is determined by the tire manufacturer and may be obtained from the tire manufacturer's handbook. To determine if the Alcoa aluminum dual wheel assembly has adequate minimum dual spacing for the selected tires, double the wheel outset measurement of the Alcoa wheel used. If the doubled outset measurement is equal to or greater than the tire manufacturer's recommendation, there will be sufficient minimum dual spacing. Wheel inset and outset is given for each Alcoa wheel in Alcoa's Wheel Product Spec Guide. Both inset and outset wheels are measured from the mounting surface of the wheel to the center line of the rim. Maintaining proper tire inflation and load ratings are essential to maintaining proper minimum dual spacing.

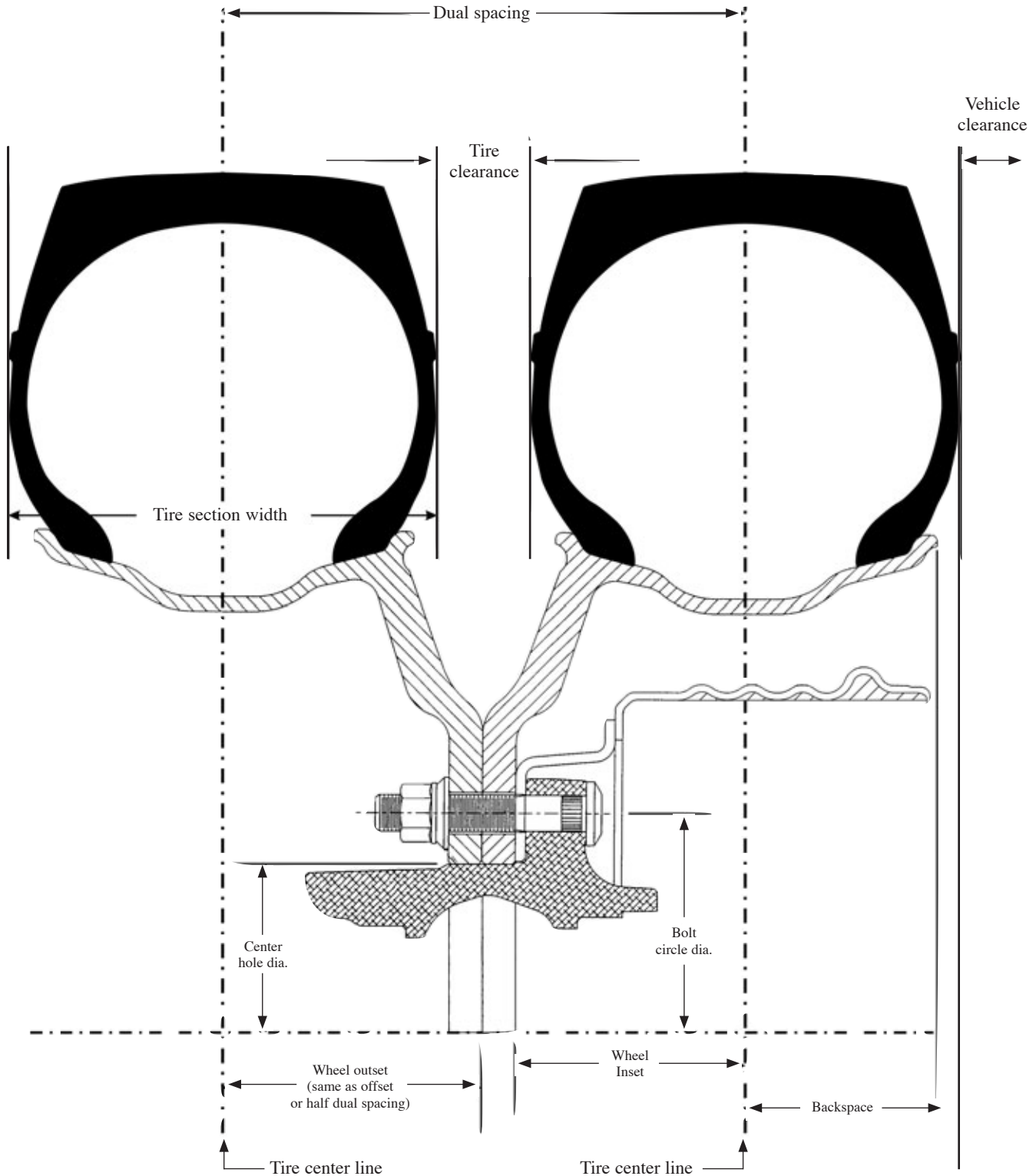

7

# 8

# Conversion Tables

Inch Fraction,  
Decimal and  
Millimeter  
Equivalents Chart  
(Up to 1 inch)

8-1

Inches	Decimals	Millimeters
1/64	0.016	0.40
1/32	0.031	0.79
3/64	0.047	1.19
1/16	0.063	1.59
5/64	0.078	1.98
3/32	0.094	2.38
7/64	0.109	2.78
<b>1/8</b>	<b>0.125</b>	<b>3.18</b>
9/64	0.141	3.57
5/32	0.156	3.97
11/64	0.172	4.37
3/16	0.188	4.76
13/64	0.203	5.16
7/32	0.219	5.56
15/64	0.234	5.95
<b>1/4</b>	<b>0.250</b>	<b>6.35</b>
17/64	0.266	6.75
9/32	0.281	7.14
19/64	0.297	7.54
5/16	0.313	7.94
21/64	0.328	8.33
11/32	0.344	8.73
23/64	0.359	9.13
<b>3/8</b>	<b>0.375</b>	<b>9.53</b>
25/64	0.391	9.92
13/32	0.406	10.32
27/64	0.422	10.72
7/16	0.438	11.11
29/64	0.453	11.51
15/32	0.469	11.91
31/64	0.484	12.30
<b>1/2</b>	<b>0.500</b>	<b>12.70</b>

Inches	Decimals	Millimeters
33/64	0.516	13.10
17/32	0.531	13.49
35/64	0.547	13.89
9/16	0.563	14.29
37/64	0.578	14.68
19/32	0.594	15.08
39/64	0.609	15.48
<b>5/8</b>	<b>0.625</b>	<b>15.88</b>
41/64	0.641	16.27
21/32	0.656	16.67
43/64	0.672	17.07
11/16	0.688	17.46
45/64	0.703	17.86
23/32	0.719	18.26
47/64	0.734	18.65
<b>3/4</b>	<b>0.750</b>	<b>19.05</b>
49/64	0.766	19.45
25/32	0.781	19.84
51/64	0.797	20.24
13/16	0.813	20.64
53/64	0.828	21.03
27/32	0.844	21.43
55/64	0.859	21.83
<b>7/8</b>	<b>0.875</b>	<b>22.23</b>
57/64	0.891	22.62
29/32	0.906	23.02
59/64	0.922	23.42
15/16	0.938	23.81
61/64	0.953	24.21
31/32	0.969	24.61
63/64	0.984	25.00
<b>1</b>	<b>1.000</b>	<b>25.40</b>

## Conversion Factors

### 8-2

#### Inches to Millimeters

---

$$\text{Inches} \times 25.4 = \text{Millimeters}$$

#### Millimeters to Inches

---

$$\text{Millimeters} \times 0.03937 = \text{Inches}$$

#### PSI to kPa

---

$$\text{PSI} \times 6.8948 = \text{kPa}$$

#### kPa to PSI

---

$$\text{kPa} \times 0.145 = \text{PSI}$$

#### Pounds to Kilograms

---

$$\text{Pounds} \times 0.4536 = \text{kg}$$

#### Kilograms to Pounds

---

$$\text{kg} \times 2.2046 = \text{Pounds}$$

#### Foot-pounds to Newton Meters

---

$$\text{Ft-lbs} \times 1.35582 = \text{N-m}$$

#### Newton Meters to Foot-pounds

---

$$\text{N-m} \times .737561 = \text{Ft-lbs}$$

# Notes



# Notes

# Notes

Alcoa Wheel Products  
1600 Harvard Avenue  
Cleveland, Ohio 44105  
(800) 242-9898

[www.alcoawheels.com](http://www.alcoawheels.com)

Copyright © 2012  
Alcoa Wheel Products  
All Rights Reserved

Form E37-13584  
Printed in USA 02/12/30M