



## MUSCLE PUMPS

# OPERATING AND MAINTENANCE MANUAL

SINGLE STAGE

Qpak

Qflo

Qmax

TWO STAGE

Qtwo



**WARNING**

Failure to follow the operating, lubrication, and maintenance requirements set forth in this operating and maintenance manual may result in serious personal injury and/or damage to equipment.

A Hale Pump is a quality product: ruggedly designed, accurately machined, carefully assembled and thoroughly tested. In order to maintain the high quality of your pump and to keep it in a ready condition, it is important to follow the instructions on care and operation. Proper use and good preventative maintenance will lengthen the life of your pump.

**ALWAYS INCLUDE THE PUMP SERIAL NUMBER IN CORRESPONDENCE.**

---

HALE PRODUCTS, INC. • A Unit of IDEX Corporation • 700 Spring Mill Avenue • Conshohocken, PA 19428 • TEL: 610-825-6300 • FAX: 610-825-6440

MANUAL P/N 029-0020-63-0, REV B, © 2000 HALE PRODUCTS, INC., PRINTED IN U.S.A.



Hale Products cannot assume responsibility for product failure resulting from improper maintenance or operation. Hale Products is responsible only to the limits stated in the product warranty. Product specifications contained in this material are subject to change without notice.



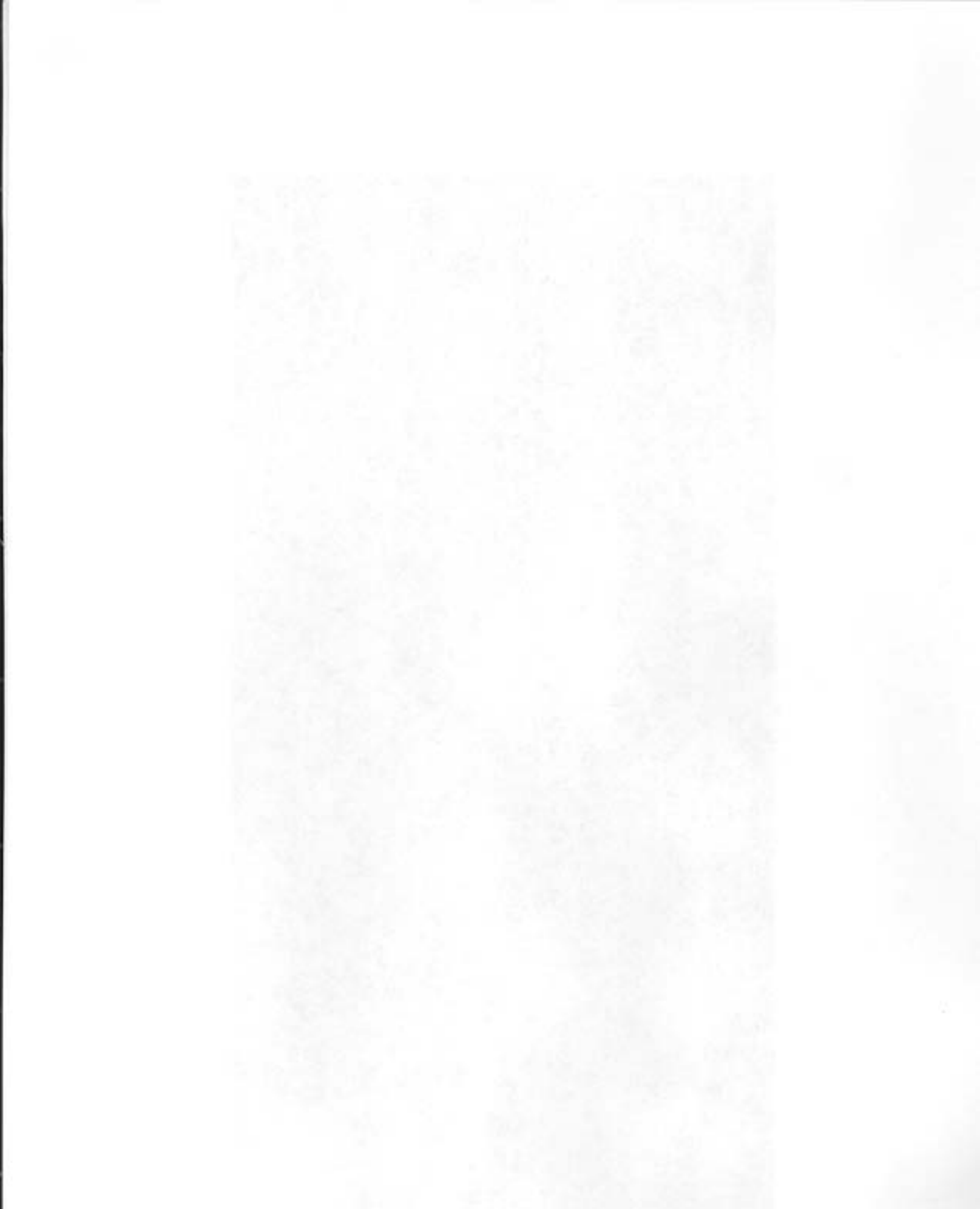

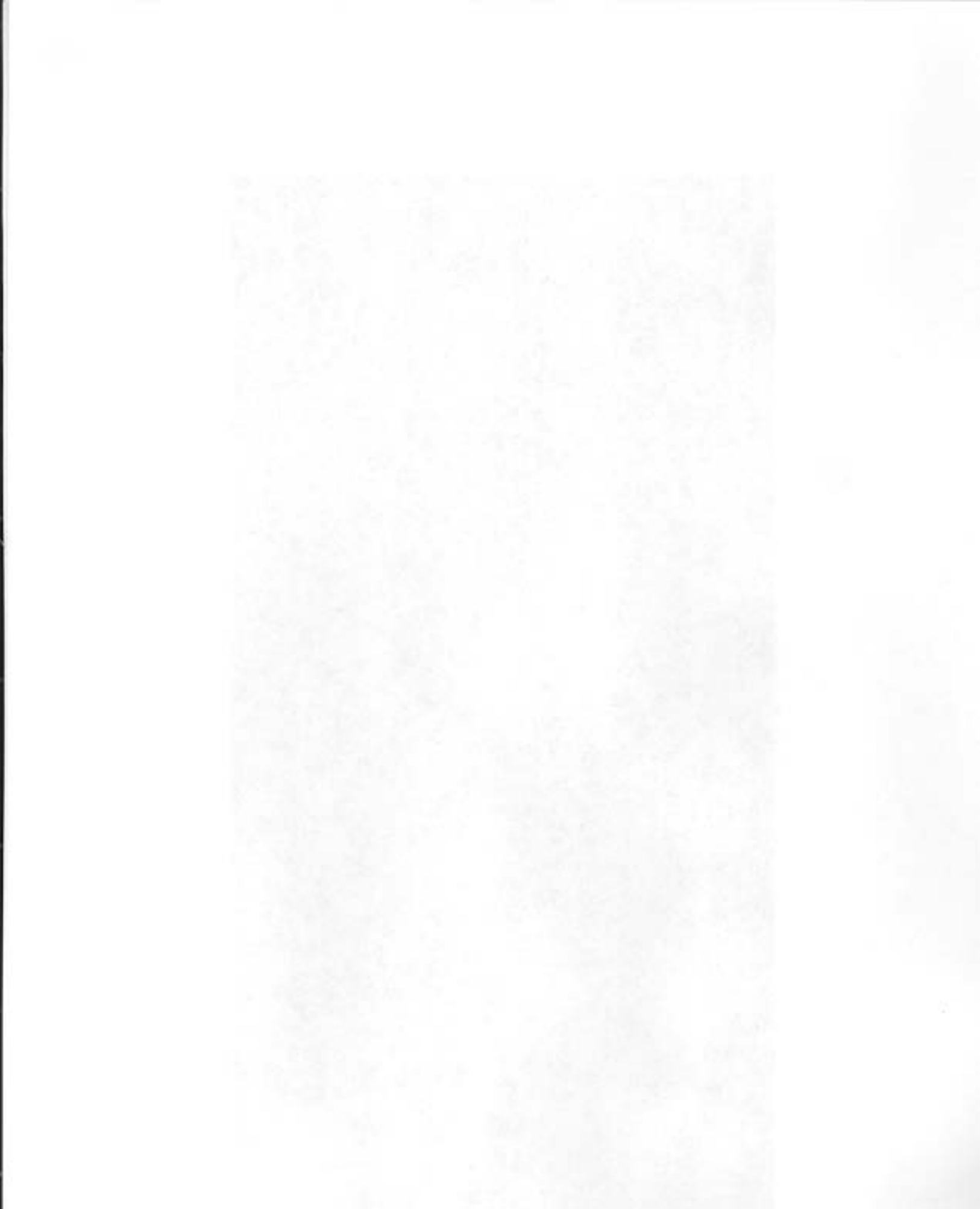



## TABLE OF CONTENTS

SECTION	PAGE
1 INTRODUCTION.....	1-1
A. Description .....	1-1
B. Principles of Operation .....	1-1
Centrifugal Force .....	1-1
Pump Stages .....	1-1
Single-Stage Pump .....	1-3
Single-Stage Pump Operation.....	1-3
Two-Stage Pump.....	1-3
Two-Stage Pump Operation .....	1-5
Volume (Parallel) Operation .....	1-5
Pressure (Series) Operation.....	1-5
Volume Versus Pressure Operation.....	1-5
Transfer Valve .....	1-6
Choosing Between Volume and Pressure Operation.....	1-6
Transferring Between Volume and Pressure Operation .....	1-6
Cavitation .....	1-7
C. Parts of Pump.....	1-8
Basic Parts of Hale Midship Centrifugal Pump .....	1-8
Pump Body .....	1-8
Qmax and Qtwo Pumps .....	1-8
Qpak and Qflo Pumps.....	1-9
Impeller .....	1-9
Clearance Rings .....	1-9
Bearings .....	1-10
Pump Seals .....	1-10
Packing.....	1-10
Mechanical Seal.....	1-11
Auto Lube ®.....	1-11
D. Pump Drives .....	1-12
Pump Mounting Options .....	1-12
G-Series Gearbox .....	1-12
Principle of Operation.....	1-12
LP and XP Gearbox.....	1-12
Shifting.....	1-12
J Series Gearbox.....	1-14
E. Accessories.....	1-14
Priming Pump .....	1-14
Priming Valves .....	1-15
Pressure Control Devices .....	1-15
Relief Valve System.....	1-15
Hale Total Pressure Master (TPM) Relief Valve System.....	1-17
Cooling Options .....	1-22
Model K Auxiliary Heat Exchanger/Cooler.....	1-22
Thermal Relief Valve (TRV).....	1-23
Valves .....	1-24
Suction Valves .....	1-24



**TABLE OF CONTENTS (CONTINUED)**

<b>SECTION</b>	<b>PAGE</b>
1	INTRODUCTION (Continued)
	Discharge Valves ..... 1-24
	Tank Suction Valves..... 1-25
	In-line Valves ..... 1-25
	Drain Valves..... 1-26
	Anodes ..... 1-26
	Booster Pump ..... 1-27
2	OPERATING PROCEDURES ..... 2-1
A.	Overview ..... 2-1
B.	Operating Procedures ..... 2-1
	Pumping From a Hydrant, General Operation..... 2-1
	TPM Operation from a Hydrant..... 2-2
	Pumping From Draft, General Operation..... 2-2
	Pumping From the Onboard Water Tank..... 2-4
	Pumping In Relay..... 2-5
	Tandem Pumping Operation From a Hydrant..... 2-6
	Pump to Road Shift Procedures..... 2-7
	Standard Relief Valve Procedures..... 2-7
	TPM Relief Valve Procedures..... 2-7
	TPM System with Engine Governor ..... 2-7
	Emergency Pump Shift Procedures..... 2-8
	Post Operation Procedures ..... 2-9
3	PREVENTATIVE MAINTENANCE..... 3-1
A.	Overview ..... 3-1
B.	Procedures..... 3-1
	Post Operation Maintenance..... 3-1
	Extreme Conditions Maintenance Guidelines ..... 3-1
	During Freezing Weather..... 3-1
	After Pumping from Salt Water, Contaminated Water, or with Foam Solution..... 3-1
	Weekly Maintenance ..... 3-1
	Relief Valve and TPM Test..... 3-2
	Governor Test..... 3-2
	Transfer Valve Test..... 3-2
	Priming System Test..... 3-2
	Pump Shift Warning Indicator Lights..... 3-2
	Valve Lubrication..... 3-3
	Monthly Maintenance..... 3-3
	Suction Check Valve Test..... 3-3
	Lubrication ..... 3-3
	Packing Gland Adjustment..... 3-3
	Drive Line and Flange Bolts..... 3-4



**TABLE OF CONTENTS (CONTINUED)**

<b>SECTION</b>		<b>PAGE</b>
3	PREVENTATIVE MAINTENANCE (Continued)	
	Pump Mounting Bolts.....	3-4
	Priming System Test (Dry Vacuum Test).....	3-4
	Relief Valve System Check.....	3-4
	Indicator Light Test.....	3-5
	Annual Maintenance.....	3-5
	Performance Testing Overview.....	3-5
	Performance Testing Equipment and Materials.....	3-5
	Performance Testing.....	3-10
	Repacking.....	3-11
	Annual MIV and 40BD Relief Valve Test and Adjustment.....	3-11
	Worn Clearance Rings and Impeller Hubs.....	3-12
	Anode Check.....	3-13
	TRV Test.....	3-13
4	TROUBLESHOOTING.....	4-1
5	CORRECTIVE MAINTENANCE.....	5-1
	A. Midship Pump.....	5-1
	Removal.....	5-1
	Installation.....	5-1
	B. Gearbox.....	5-3
	G-Series.....	5-3
	Removal.....	5-3
	Installation.....	5-3
	J-Series.....	5-6
	Removal.....	5-6
	Installation.....	5-6
	C. Packing Replacement.....	5-7
	D. Mechanical Seal Replacement.....	5-7
	Qmax and Qtwo Pump Mechanical Seal.....	5-7
	Removal.....	5-7
	Installation.....	5-9
	Qflo and Qpak Pump Mechanical Seal and Clearance Rings.....	5-10
	Removal.....	5-10
	Installation.....	5-12
	E. AutoLube® Service (Qmax/Qtwo).....	5-13
	F. Impeller Assembly.....	5-15
	Impeller and Clearance Rings Removal.....	5-15
	Disassembly (Single-Stage Pump).....	5-16
	Assembly (Single-Stage Pump).....	5-16
	Disassembly (Two-Stage Pump).....	5-17
	Assembly (Two-Stage Pump).....	5-18
	Installation (Impeller and Clearance Rings).....	5-18
	G. Relief Valve System.....	5-20



**TABLE OF CONTENTS (CONTINUED)**

<b>SECTION</b>		<b>PAGE</b>
5	CORRECTIVE MAINTENANCE (Continued)	
	PM/PMD Control Valve .....	5-20
	QD Relief Valve.....	5-21
	QG Relief Valve.....	5-23
	PG30 Relief Valve .....	5-24
	Sensing Valve .....	5-25
H.	TRV Service.....	5-26
I.	Anode Replacement.....	5-26
J.	Qtwo Transfer Valve .....	5-27
K.	Qtwo Check Valves (Two-Stage Only) .....	5-28
L.	Tank To Pump Check Valve .....	5-29
M.	Suction Extension and Suction Tube .....	5-29
N.	Gearbox Disassembly and Assembly .....	5-30
	G-Series.....	5-30
	Removal and Disassembly .....	5-30
	Assembly and Installation .....	5-33
	J-Series.....	5-35
	Removal and Disassembly .....	5-35
	Assembly and installation .....	5-36
O.	Primers.....	5-37
	ESP Priming Pump .....	5-37
	SPV Priming Valve .....	5-38
	PVG Priming Valve.....	5-38
P.	Accessories.....	5-39
	Valves .....	5-39
	40BD Series Valve Maintenance .....	5-40
	40BD Valve Seat Replacement .....	5-41
	Valve Stem Seal Replacement.....	5-42
	Drain Valve Repair Procedures .....	5-42
6	PARTS LISTS.....	6-1
	GLOSSARY.....	G-1

**APPENDICES**

Data for Practical Use	A
Parts and Service Centers	B
Warranty	C

## 1. INTRODUCTION

### A. Description

Hale single-stage and two-stage midship pumps are favorites of firefighters throughout the world. Covering a range of capacities from 750 Gallons Per Minute (GPM) (2,838 Liters Per Minute, LPM) to 2,250 GPM (8,516 LPM), Hale pumps offer the versatility, dependability, reliability, and ease of operations necessary for effective fire fighting. This section reviews the principles of operation of Hale's single-stage and two-stage midship pumps.

### B. Principles of Operation

#### Centrifugal Force

A centrifugal pump operates on the principle that centrifugal force is created by a rapidly spinning disk. Figure 1-1 shows that an amount of water has been placed at the center of a disk. The disk is rotated at some speed, and the water is thrown from the center toward the outer circumference of the disk. The distance that the water travels from the center directly relates to the diameter of the disk and the speed of rotation. When water is confined in a closed container (such as the pump body), its pressure rises to a level that depends on the speed of rotation. There are three interrelated factors that regulate the performance of a centrifugal pump:

- **SPEED (RPM).** If the speed of rotation increases with flow held constant, the water pressure increases.
- **PRESSURE.** Pressure is usually measured in Pounds Per Square Inch (PSI) (BAR). If pressure changes with speed held constant, the flow (measured in GPM) (LPM) will change inversely, that is, if pressure increases, flow decreases.
- **FLOW.** Flow is usually measured in the number of gallons of water per minute (GPM) (LPM) that a pump can deliver when supplied from draft. If the pressure is held constant, the flow will increase with an increase in the speed of rotation.

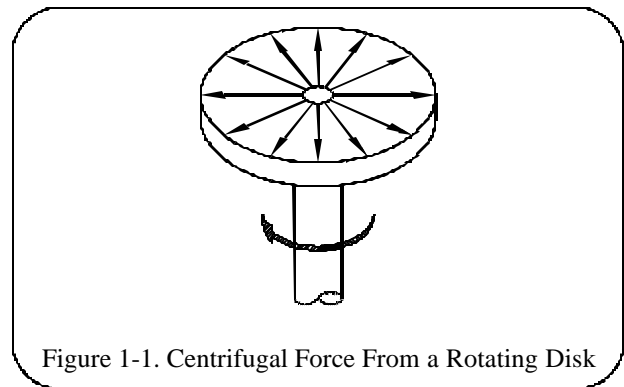

Figure 1-1. Centrifugal Force From a Rotating Disk

The centrifugal pump is preferred by the fire protection service due to its ability to fully utilize any positive suction inlet pressure, reducing the amount of work done by the pump. For example, if the required discharge pressure is 120 PSI (8 BAR), and the inlet pressure is 45 PSI (3 BAR), the pump must only produce the difference in pressures of 75 PSI (5 BAR). This contributes to low engine and pump speeds with reduced maintenance. Decreased maintenance is aided by the fact a centrifugal pump has basically only two moving parts the impeller and the shaft.

#### Pump Stages

The number of impellers on a common shaft determines the number of pump stages. The Hale series of single-stage pumps provides the same normal operating and rating test pressures as the Hale series of two-stage pumps. The two-stage pump provides an additional level of operating pressures if required, but adds some operating complexity.



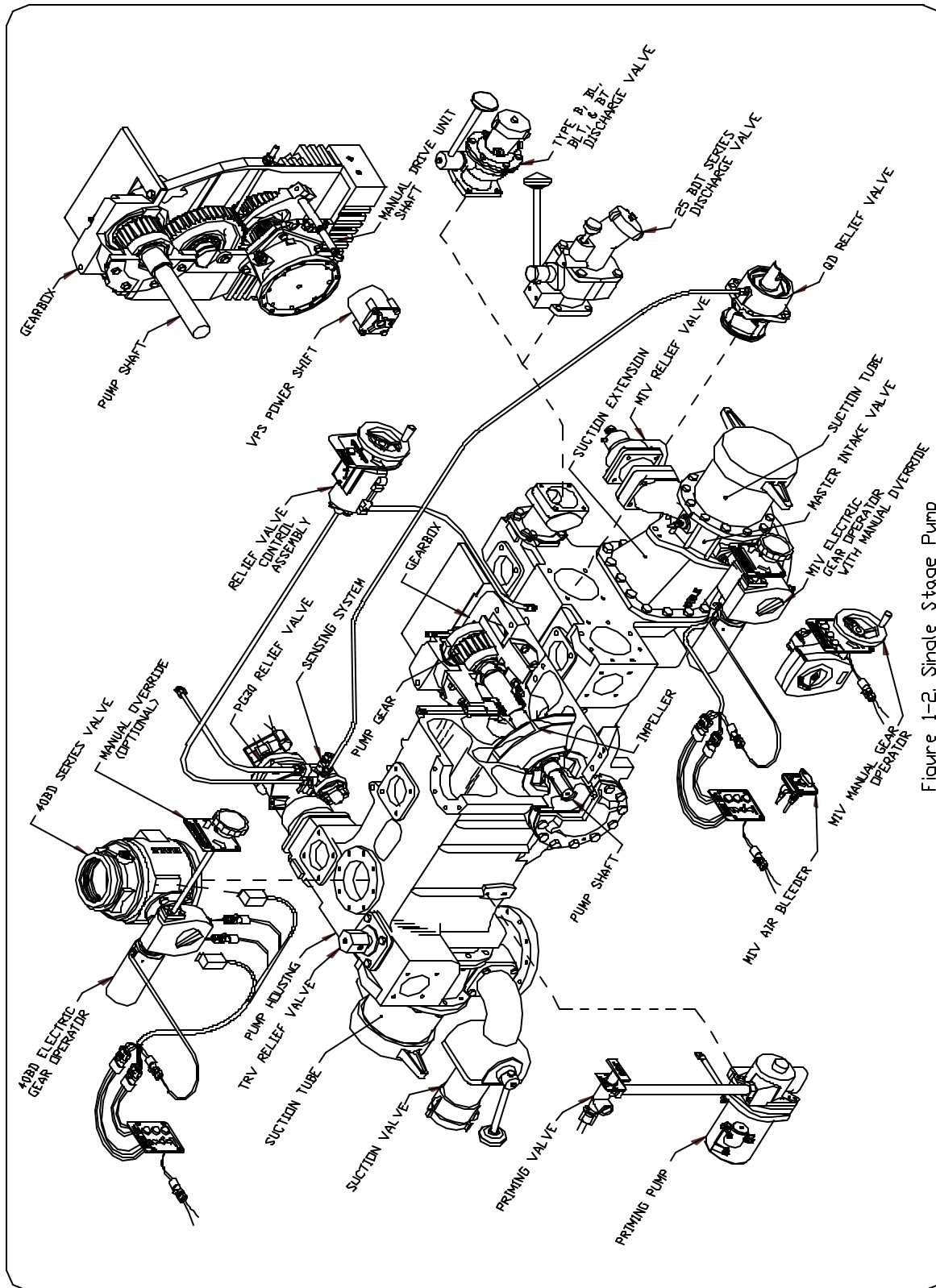

Figure 1-2. Single Stage Pump

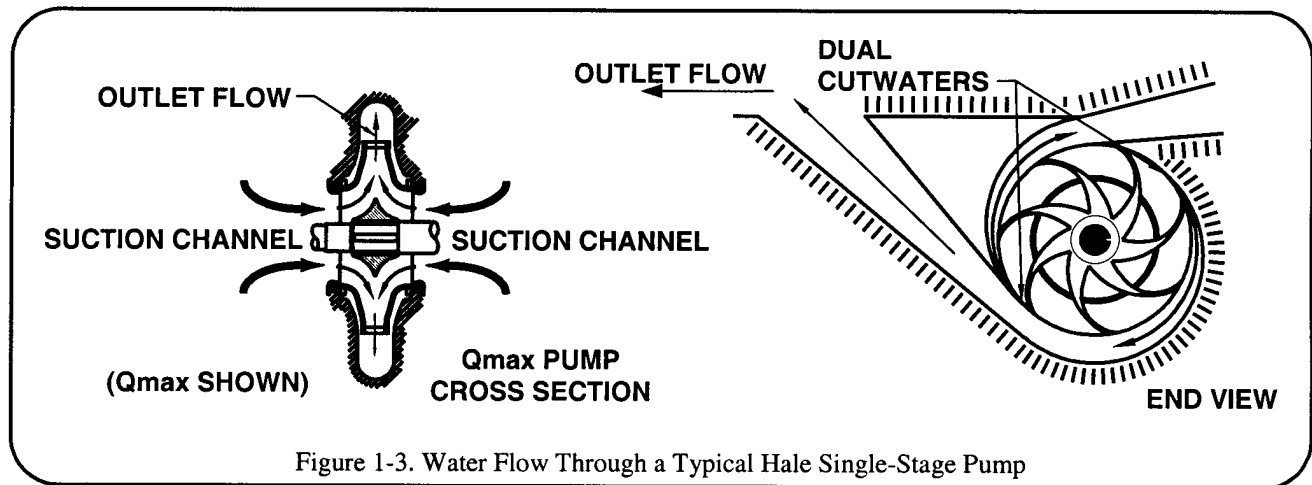

Figure 1-3. Water Flow Through a Typical Hale Single-Stage Pump

### Single-Stage Pump

There are three series of single-stage pumps.

- ❑ Qpak – 500 GPM to 1000 GPM (1,892 LPM to 3,785 LPM)
- ❑ Qflo - 750 GPM to 1,250 GPM (2,838 LPM to 4,731 LPM)
- ❑ Qmax - 1,000 GPM to 2,250 GPM (3,785 LPM to 8,516 LPM)  
(See figure 1-2)

Hale single-stage pumps are of a size and design to attach to the chassis rails of commercial and custom chassis. The pump is driven from the truck's main driveline. Generally, the pump consists of the following major components:

- ❑ Pump body
- ❑ Impeller and Shaft Components
- ❑ Gearbox
- ❑ Priming System
- ❑ Pressure Control Device
- ❑ Valves

### Single-Stage Pump Operation

Hale single-stage pumps use a single impeller to develop the required volume and pressure. Figure 1-3 shows the flow of water through the Hale Qmax single-stage pump. Water enters the suction channels on both sides of the impeller, thereby maintaining axial balance. Dual cutwaters on the Qmax strip water from the rotating impeller and direct it to the discharge path. The Qflo and Qpak

pumps utilize an impeller with a single suction channel where water enters. The impeller develops discharge pressure and directs the water to a single cutwater and then to the discharge valves. The impellers are radially and axially balanced. Radial hydraulic balance in the Qmax and Qtwo is maintained by the opposed discharge volute cutwaters. The cutwaters are wedge shaped and divide the water between the volute and the pump discharge.

### Two-Stage Pump

There is one series of two-stage pump:

- ❑ Qtwo - 1,000 to 2,000 GPM (3,785 LPM to 7,570 LPM)  
(See figure 1-4)

Hale two-stage pumps are of a size and design to mount on the chassis rails of commercial and custom chassis. The pump is driven from the truck's main driveline. Generally, the pump consists of the following major components:

- ❑ Pump Body
- ❑ Impeller and Shaft Components
- ❑ Gearbox
- ❑ Priming System
- ❑ Pressure Control Device
- ❑ Transfer Valve System
- ❑ Valves

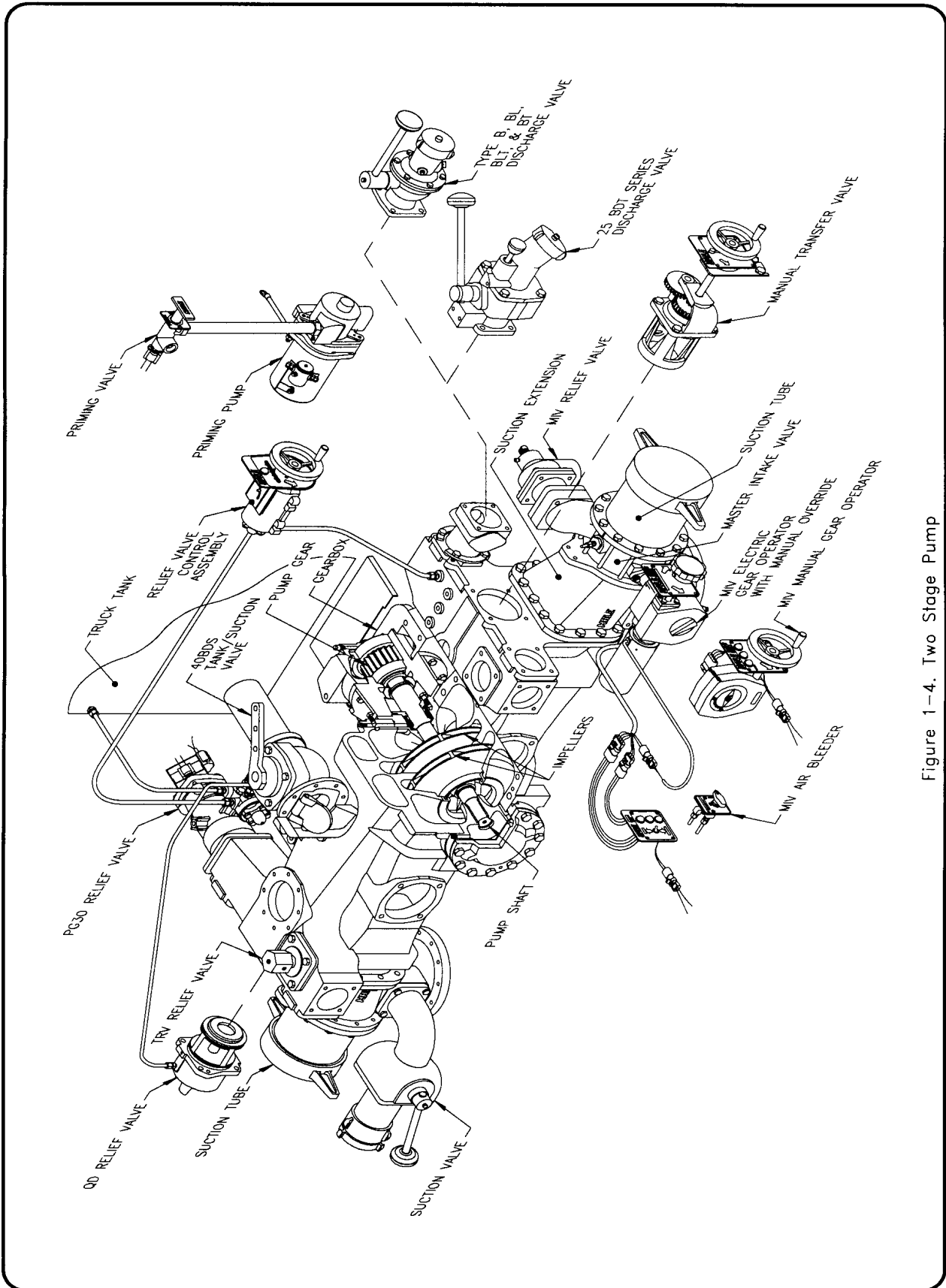

Figure 1-4. Two Stage Pump

## Two-Stage Pump Operation

The primary difference between a single-stage and a two-stage pump is that the former has only one impeller and no transfer valve to switch between volume and pressure operation. A transfer valve is a two-position valve that permits the impellers in a two-stage pump to be operated in parallel (volume) or series (pressure). Both types of operation are explained in the following paragraphs.

### Volume (Parallel) Operation

Volume operation (figure 1-5), results in the pressure at the pump intake being added to the pressure developed by both impellers, and the amount of water delivered to the discharge being the sum of the flows of the two impellers. For example, if the inlet pressure is 30 PSI (2 BAR) and the flow of each impeller is 500 GPM (1,892 LPM) at 150 PSI (10 BAR), the pressure and volume at the discharge is:

Flow/Impeller x # Impellers

1,000 GPM (3,785 LPM) at 180 PSI (12 BAR):

500 GPM per Impeller X 2 Impellers = 1,000 GPM  
 (1,892 LPM per Impeller X 2 Impellers = 3,785 LPM)  
 30 PSI Inlet Pressure + 150 PSI Pump Pressure = 180 PSI

(2 BAR Inlet Pressure + 10 BAR Pump Pressure = 12 BAR)

### Pressure (Series) Operation

Pressure operation (figure 1-6), finds the impellers connected in series. That is, the output of the impeller supplied from the pump intake is supplied to the input of the next impeller. The pressure at the pump discharge is the sum of the pressure of the two impellers plus the pressure of the intake. The amount of water delivered to the discharge is the same amount that entered the first impeller. Using the example above when in series operation, the discharge pressure will be 330 PSI, (22 BAR) and the discharge volume will be 500 GPM (1,892 LPM).

### Volume Versus Pressure Operation

Selection of volume versus pressure operation is determined by three factors:

- ❑ Generally, the pump should be operated so that the pump gives the desired performance at the lowest engine speed.
- ❑ Transfer to volume (parallel) operation for higher flows (see figure 1-5).
- ❑ Transfer to pressure (series) operation when higher water pressures are required (see figure 1-6).

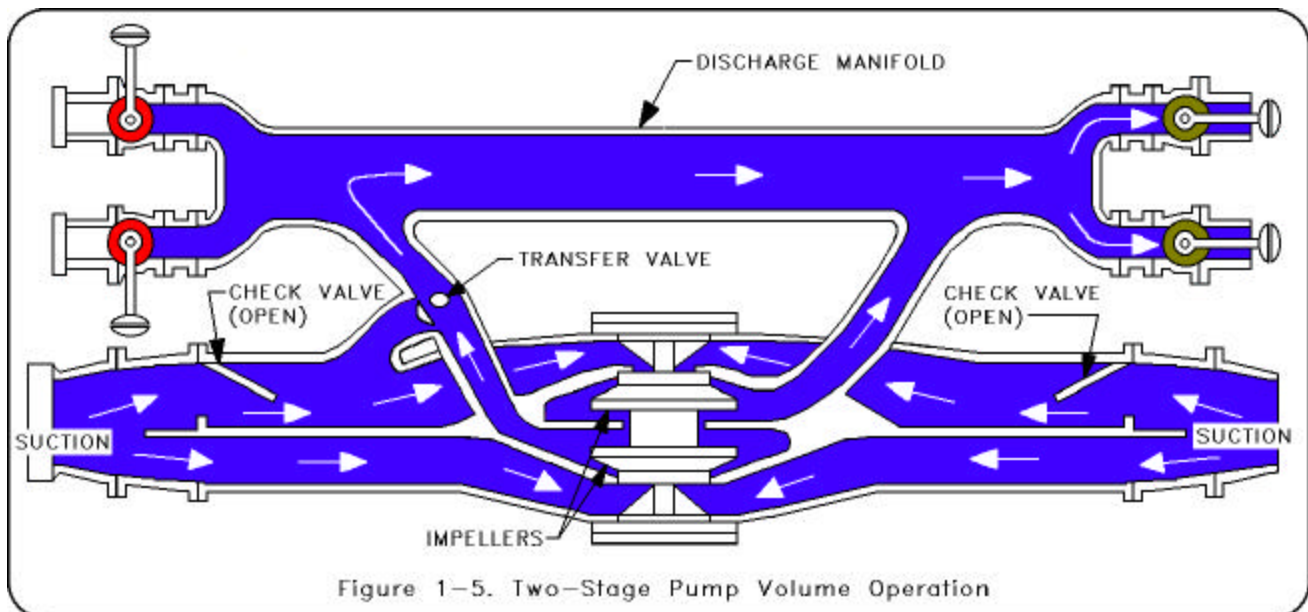

Figure 1-5. Two-Stage Pump Volume Operation

## Transfer Valve

A transfer valve, which is controlled from the apparatus pump control panel, allows the operator of a two-stage pump to select volume or pressure operations. This valve is an all-bronze waterway device that can transfer between pumping modes with two and one-half turns of its control hand wheel. The position of the valve is indicated on the apparatus pump control panel via a positive mechanical indicator. An optional power transfer valve is available.

operations. If your fire department does not have a policy to follow, here are general guidelines:

1. Hale pumps are designed to pump up to 200 PSI (13 BAR) net pressure in volume operation at reasonable engine speeds.
2. Generally, volume operation should be used at any net pump pressure under 150 PSI (10 BAR), especially when pumping from a hydrant.

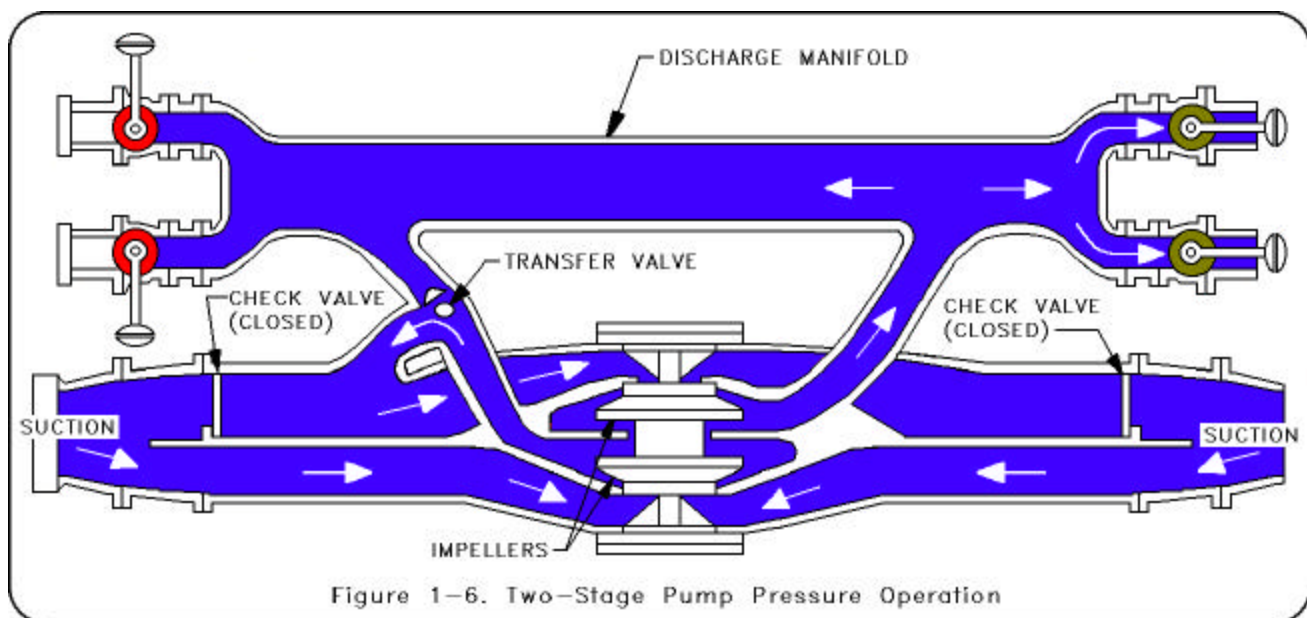

## Choosing Between Volume and Pressure Operation

In deciding which range to pump (*pressure or volume*), choose the one that gives the desired flow and pressure at the lowest engine speed. When a change of range is desired, slow down to idle speed, and shift the transfer valve to the desired range. When shifting the transfer valve from *volume* to *pressure* operation, the pressure will be doubled. You may hear a metallic click or two clicks, which will be the check valves closing. If the clicks sound too harshly, you are changing the transfer valve while the pressure is too high. This happens when the truck engine is running at high speed.

Refer to your fire department policy for when to use volume operation and when to use pressure

3. When pumping from draft or a water tank, pressure operation may be used when the volume is less than one-half the pump capacity and when the desired pressure is over 150 PSI (10 BAR).
4. Be certain to warn everyone involved before changing pump range.

## Transferring Between Volume and Pressure Operation

Transferring between volume and pressure operation is evidenced by a metallic click, which results from the check valves closing. If the click is too loud or, perhaps, somewhat violent, the pumping pressure is too high for switching. In this case, you should ease back on the engine throttle.



Switching between volume and pressure operation is generally governed by prevailing fire department policy. However, here are some general guidelines if our fire department does not have an established policy:

1. The pump should be operated so that engine speed is within its best operating range.
2. Transfer to volume (parallel) operation if the pump has to discharge more than 50 percent of its rated capacity. Be certain to warn everyone involved before switching between volume and pressure operation.
3. Reduce the pump pressure to 50 to 60 PSI (3 to 4 BAR) before switching. The engine speed should especially be reduced when switching from volume to pressure operation with hand held hoses in use.

### Cavitation

Cavitation occurs when a centrifugal pump is attempting to discharge more water than it is receiving. When cavitation occurs, a vacuum is created near the eye of the impeller. As the vacuum increases, the boiling point of the water is lowered until it reaches a point near the impeller eye where it flashes into vapor and enters the impeller. Once the vapor pockets, or bubbles, enter the impeller,

the process begins to reverse itself. As the vapor reaches the discharge side of the pump, it is subjected to a high positive pressure, which condenses the vapor back to a liquid. The sudden change from vapor pockets to a liquid generates a shock effect which causes a significant noise that is characteristic of cavitation. This shock damages the impeller and pump housing. This may happen while pumping from draft or a hydrant. The problem in either case is the pump running away from the supply and this causes a vacuum to occur. Cavitation is often referred to as “the pump running away from the water supply”. This means that the operator is trying to pump more water out of the pump than is going into the pump. To eliminate cavitation, the operator must be aware of the warning signs and correct the situation, or serious damage to the pump and impeller will occur. The most reliable indication that a pump is approaching cavitation is when an increase in engine RPM does not cause an increase in the pump discharge pressure. The operator must not depend entirely on the vacuum gage to indicate when a pump is nearing cavitation. This is because the vacuum gage is usually tapped into the intake chamber several inches away from the leading edge of the impeller eye where the greatest amount of vacuum occurs. The most common way to eliminate cavitation is to decrease the amount of water being discharged. This is accomplished by decreasing engine speed or closing discharge valves. This will allow pressure to increase but this will result in a reduction of flow.



### C. Parts of Pump

#### Basic Parts of Hale Midship Centrifugal Pump

Figure 1-7 shows the basic parts of a Hale midship centrifugal pump. These parts are briefly described in the following text.

#### Pump Body

The standard pump body and related parts are constructed from fine grain alloy cast iron, with a minimum tensile strength of 30,000 PSI (207 N/mm<sup>2</sup>). All moving parts subject to water contact. The pumps are also available with a bronze body for use with saltwater or harsh water applications.

#### Qmax and Qtwo Pumps

The Qmax and Qtwo pump body is split horizontally on a single plane in two sections for easy removal of the entire impeller assembly, including clearance rings and bearings. The impeller assembly is removed from the bottom of the pump to avoid interference with the surrounding piping and pump mounting on the apparatus chassis.

Two tank suction valve locations are available to allow higher flows from the booster tank. Optional built-in check valves are available to prevent tank over-pressurization.

The Qmax and Qtwo pumps have two large suction inlets, on the left and right side. Additional front and rear inlets may be added as requested by the customer.

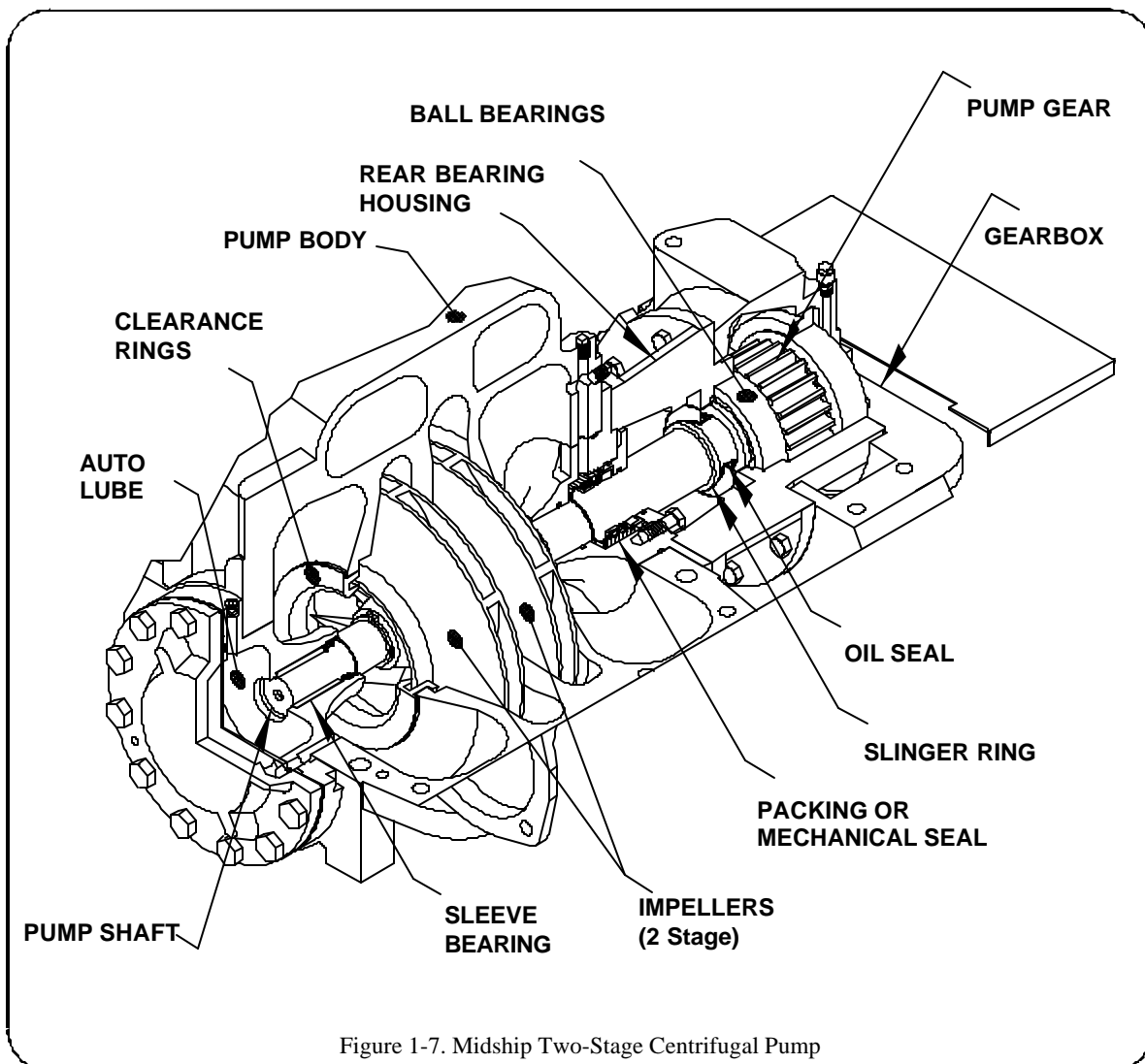

Figure 1-7. Midship Two-Stage Centrifugal Pump

Impeller inlets are on opposite sides of the pump to balance axial forces; discharges are on opposite sides to balance radial forces.

**Qpak and Qflo Pumps**

The Hale Qpak and Qflo pump body is a single piece. Service of the impeller, clearance rings and mechanical seal is accomplished by removing the gearbox and rear pump head/bearing housing from the pump. This can be accomplished without disturbing discharge or suction piping attached to the pump.

The Qpak and Qflo pump has two large suction inlets on the left and right sides. The incoming water is directed to the impeller through the suction passages.

A tank suction valve opening, located on the rear of the Qpak and Qflo pump allows for high flows from the booster tank. An optional built-in check valve is available to prevent tank over-pressurization.

Hale muscle pumps are “manifolded” type pumps meaning the pump volute, suction manifold, and discharge manifold are cast as one piece. This one-piece pump design simplifies installation of the pump and plumbing of the discharge piping.

Discharge valves in the basic pump configuration can be mounted at either side of the pump body. However, the manifolded pump body provides several additional discharge locations (facing front, back, or up) that can accommodate additional discharge valves.

**Impeller**

The impeller provides velocity to the water. This part is mounted on a shaft that is rotated by the drive. Water enters the rotating impeller at the intake (or eye), and is confined by the shrouds and the vanes mounted in the impeller to build pressure. The vanes guide water from the inlet to the discharge and reduce the turbulence of the spinning water. Vanes curve away from the direction of rotation so water moves toward the outer edge. The shrouds form the sides of the impeller, and keep the water confined to centrifugal acceleration.

Figure 1-8 traces a drop of water from the intake of the impeller to the discharge outlet. The impeller is mounted so that the discharging tube is widest at the pump outlet. The increasing discharge path, known as the volute, collects the water at a constant velocity. A further increase in pressure and a decrease in velocity take place in the diffuser.

**Clearance Rings**

Clearance rings prevent the water that is pressurized and leaving the pump volute from returning to the intake of the impeller. Centrifugal pumps have clearance rings at the impeller intake to prevent leakage. This is accomplished by limiting the radial clearance between the spinning impeller and the stationary clearance ring. Refer to figure 1-7.

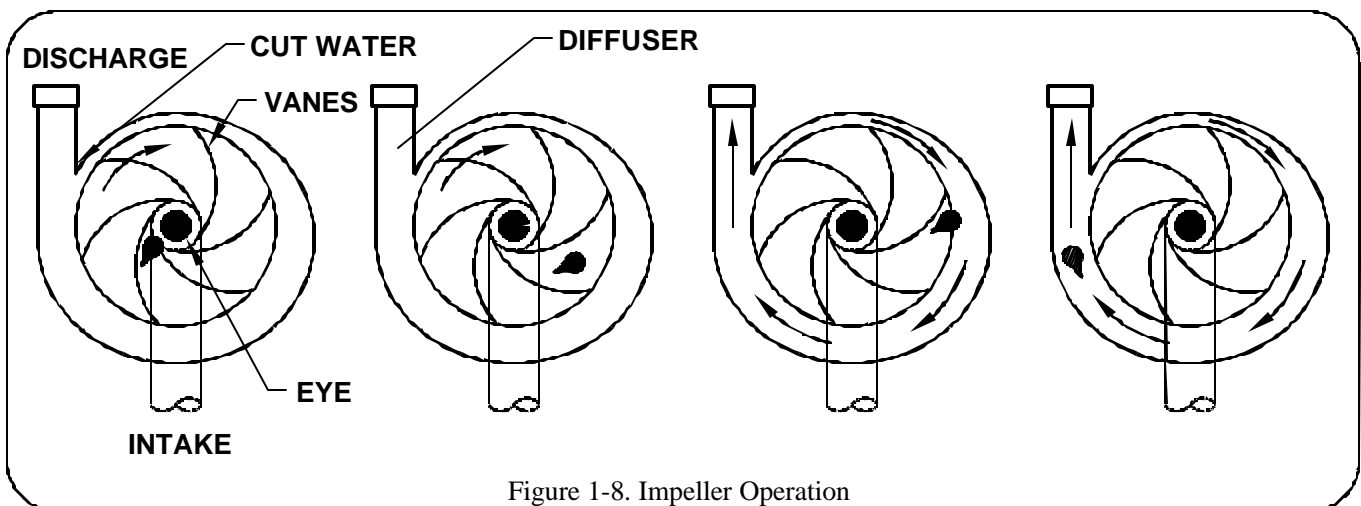

Figure 1-8. Impeller Operation



A clearance ring usually has a radial clearance of about 0.0075-inch or a 0.015-inch diameter. However, the clearance will increase over time as the pump is operated. Wear is due to foreign material found in the water. Clearance rings are designed for replacement as the clearance increases from usage and wear.

If a pump is operated without water for extended periods or without discharging water, it may overheat. This may damage the pump and the drive mechanism.

**Bearings**

Bearings support and align the impeller shaft for smooth operation (see figure 1-7).

**Pump Seals**

There are two types of seals available for Hale midship pumps, packing and mechanical.

**Packing**

Packing available on Qmax and Qtwo pumps forms a nearly watertight seal at the point where the shaft passes from the inside to the outside of the pump (see figure 1-9). Packing material is cooled with pump water. The packing gland should not be excessively tightened, or the material will lose its built-in lubrication and dry out, which may result in damage to the pump. The single packing gland is located on the low-pressure side of the pump. Its split design promotes ease of repacking. The packing nut is full circle threaded type to exert a uniform pressure on packing and to prevent cocking and uneven packing load. The packing is easily adjusted with a rod or screwdriver. The packing rings are made of a combination of unique materials and have sacrificial zinc separators to protect the pump shaft from galvanic corrosion. Packing material may also deteriorate if the pump is kept dry for long periods of time during winter months (for example, to prevent freezing). In this case, charging the pump with water at least once weekly will prevent deterioration. See the Maintenance Instructions in Section 3 for details.

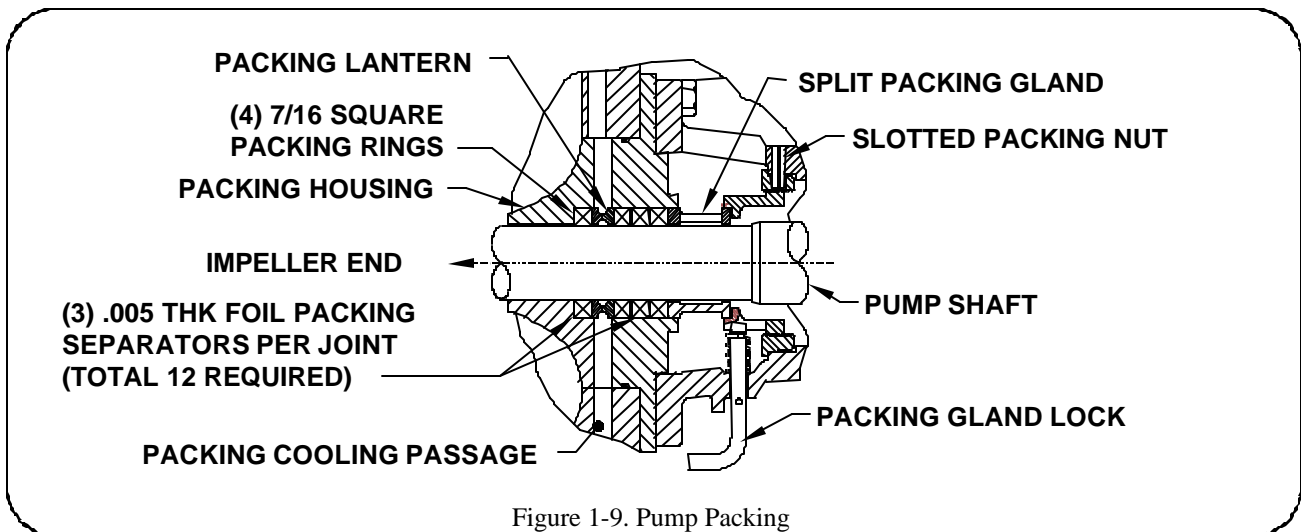

Figure 1-9. Pump Packing

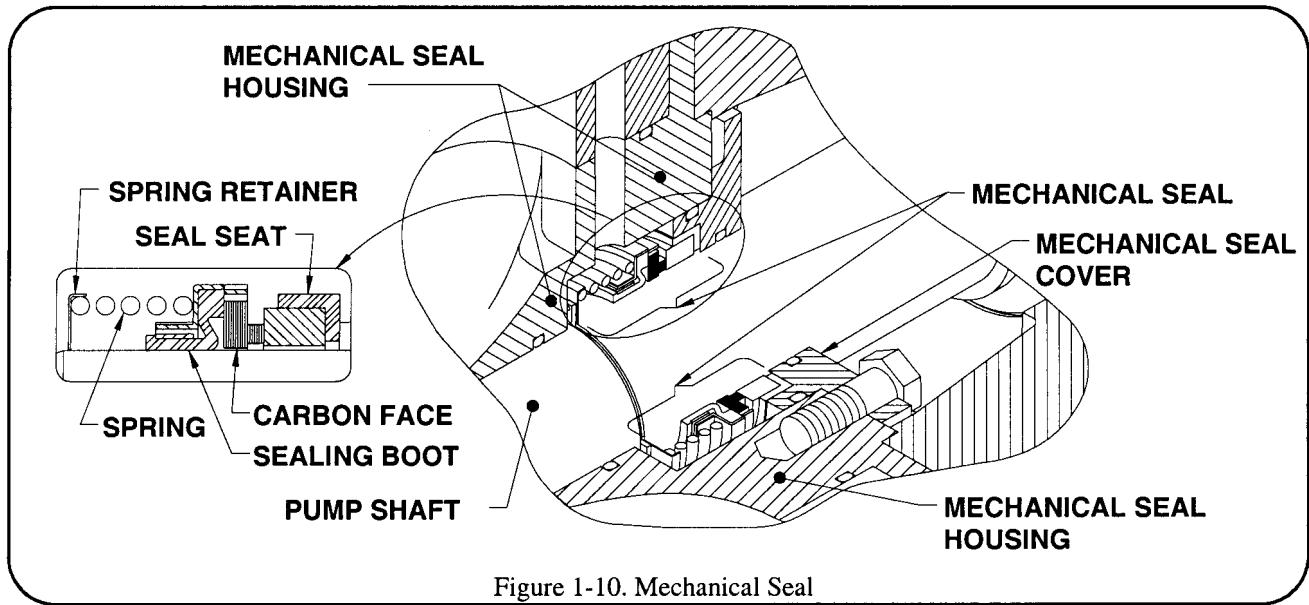

Figure 1-10. Mechanical Seal

### Mechanical Seal

The mechanical seal is standard on the Qpak and Qflo pumps and is available as an option on the Qmax and Qtwo pumps. As shown in figure 1-10, a stationary seal seat is in constant contact with a rotating carbon face to prevent leakage. The sealing boot is made of a rubber elastomer that is specifically designed for high temperature operations.

### Auto Lube ®

A miniature centrifugal pump is built into the shaft of Hale Qmax and Qtwo model pumps (see figure 1-11). This miniature pump continuously forces oil from the reservoir, through the bearing, and back again. A balancing chamber behind the oil reservoir is connected by a passage to the inlet side of the pump. This chamber always keeps the pressure in the oil reservoir equal to water pressure – whether you are pumping at high inlet pressure or pulling vacuum.

The miniature pump adds enough extra pressure to constantly keep the flowing oil a few PSI higher than water pressure. Thus, oil pressure inside the double lip-type seal is always slightly higher than water pressure outside. Dirt and water are repelled by this higher pressure.

Auto-Lube® does more than just fight off dirt. It ensures continuous lubrication, even when you are pumping dry. It permits the use of a compact, double lip-type oil seal, and maintains a constant film of oil under this seal to prevent shaft wear. Because it is built into the main pump body, it completely eliminates the need for a second set of packing, or a second mechanical seal.

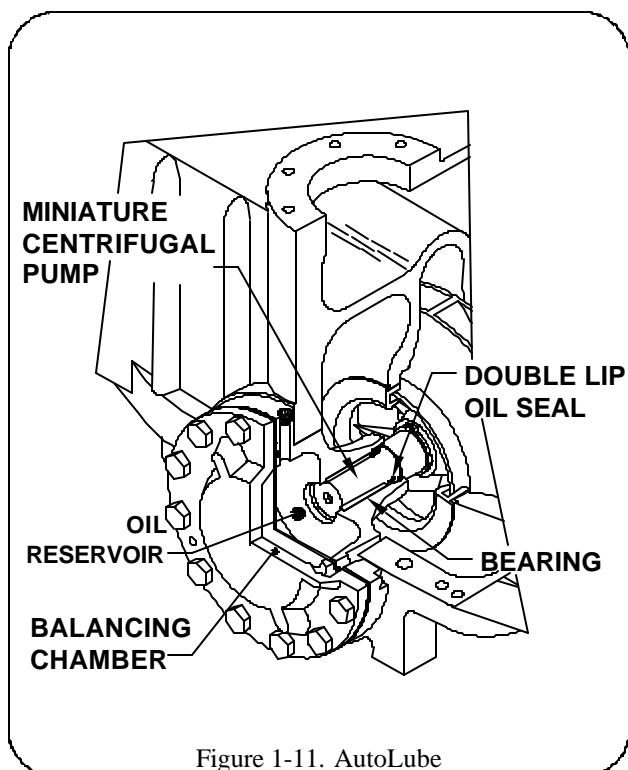

Figure 1-11. AutoLube

## D. Pump Drives

### Pump Mounting Options

There are four common types of centrifugal pump drives used with fire fighting apparatus:

- ❑ Operation from the truck chassis drive shaft (split-shaft gearbox).
- ❑ Operation from a separate engine.
- ❑ Operation from the front of the truck chassis engine (front engine PTO) crankshaft.
- ❑ Operation from a PTO from the truck transmission, a PTO before the engine drive transmission or a PTO from the four-wheel drive transfer case.

### G-Series Gearbox

The most common pump drive is the split-shaft gearbox.

The Hale G-Series split-shaft gearbox is available as a short (S), long (L), or extra long (X) model. The model designation S, L, or X, provides for different distances from the pump centerline/mount location to the center of the drive shaft for proper drive line angles. The location, pump and drive line angle determine the optimum gearbox length selection.

Hale offers a variety of pump gear ratios to accommodate a wide range of apparatus manufacturer requirements based on engine speed and available horsepower. The gearbox (figure 1-12) consists

of the gearbox, gear set, and input and shafts that are both made of heat-treated nickel steel. This unit can withstand the full torque of the engine in road operating conditions up to 16,000 pounds-feet (21,693 N-m).

### Principle of Operation

Midship pumps are so named because of their location on the fire apparatus. They are normally driven through an integral transmission that has a sliding gear shaft and sliding gear that selectively directs the engine power to the pump or the rear axle. Figure 1-13 shows the typical midship pump split-shaft arrangement on a typical chassis.

The midship transmission is capable of handling full engine horsepower, enabling the pump to meet optimum performance levels as well as all torque requirements for over the road applications.

### LP and XP Gearbox

In addition to the standard Hale gearboxes there is also available a “P” series gearbox. The “P” series gearbox contains a third stage “power take-off” that permits the mounting of an air compressor or other auxiliary drive component.

### Shifting

If the gearbox is equipped with a power shift system, an in-cab control valve is provided for mode selection. This control locks in place for pump operation. Indicator lights are provided to alert the operator when the gearbox has fully shifted from road to pump position. Additionally, provision is provided for manual shift due to failure of the power shift system.

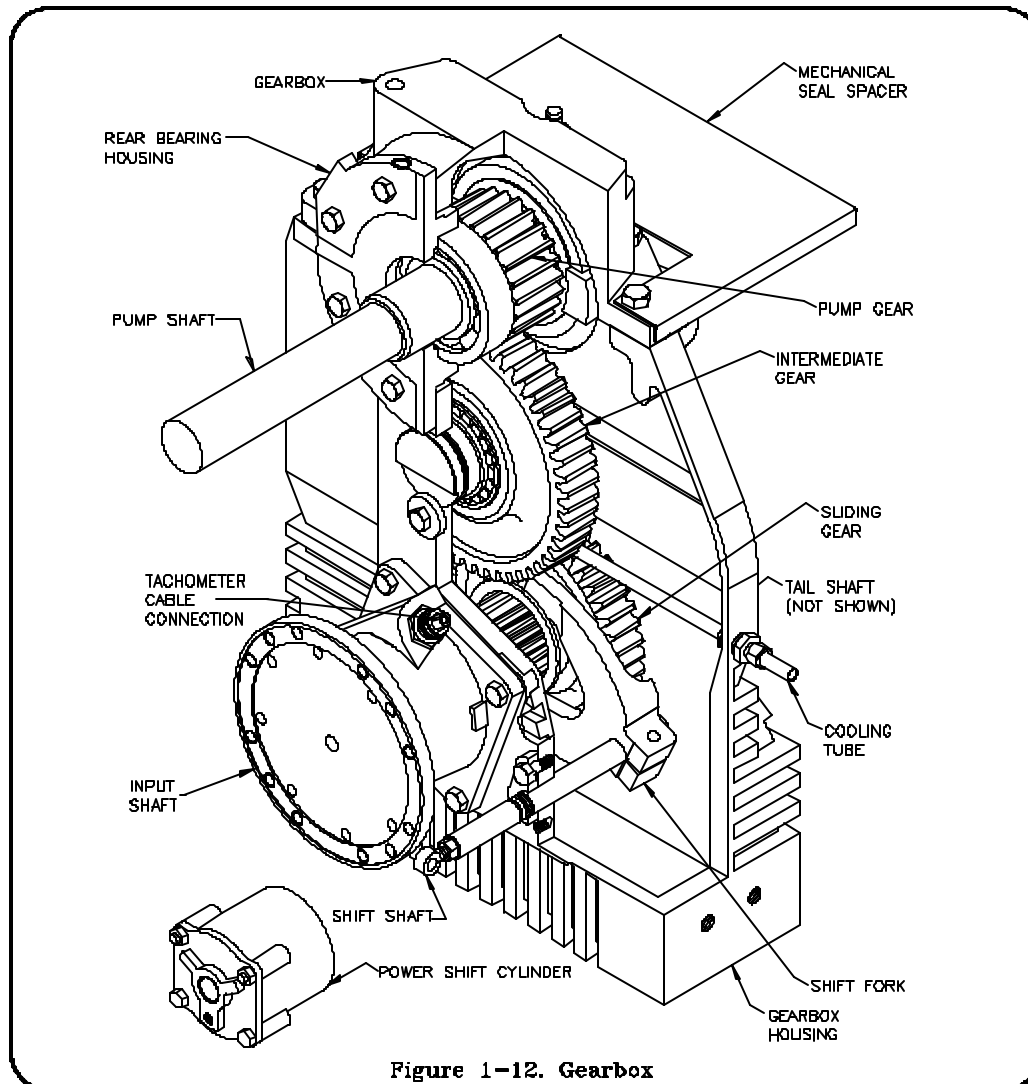

Figure 1-12. Gearbox

PUMP MODELS	GPM RANGE	STAGES	INTEGRAL MANIFOLD	AVAILABLE GEAR RATIOS
Qpak	500-1000	SINGLE	YES	HALE "L", "X", "J" GEARBOXES
Qflo	750-1250	SINGLE	YES	HALE "L" AND "X" GEARBOXES
Qmax	1000-2250	SINGLE	YES	HALE "S", "L", "X" GEARBOXES
Qtwo	1000-2000	TWO	YES	HALE "S", "L", "X" GEARBOXES

HALE "J" GEARBOX RATIOS:  
1:1.64, 1.80, 2.08, 2.35, 2.50

HALE "S" AND "L" GEARBOX RATIOS:  
1:1.58, 1.71, 1.86, 2.05, 2.28

HALE "X" GEARBOX RATIOS:  
1:1.96, 2.13, 2.32, 2.55, 2.83

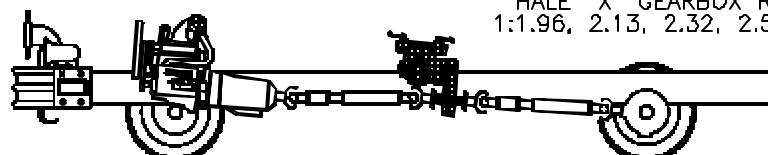

Figure 1-13. Midship Split-Shaft Pump Drive Applications

## J-Series Gearbox

The Hale J-Series Gearbox, available for the Qpak pump, is a heavy duty gearbox that is driven from a transmission-mounted PTO allowing for pump and roll applications. This gearbox has a wide range of ratios available to allow for use on different engine and transmission combinations.

## E. Accessories

### Priming Pump

Priming pumps are used to create a vacuum: they are designed to evacuate air in the suction hose and the pump. The vacuum created allows atmospheric pressure to push water from the open source through the suction hose and into the pump. Hale centrifugal midship pumps use Rotary Vane Positive Displacement pumps for priming. A positive displacement pump moves a specified amount of air or fluid with each revolution. As shown in figure 1-14, the priming pump has a single rotor mounted off-center (eccentric) to the pump body housing. The vanes in the rotor slide in grooves and are held against the body housing by centrifugal force. As a vane

turns toward the discharge, it recedes into the rotor. As the rotor continues past the discharge, the vane advances outward from its groove and against the body housing. During this cycle, the space between the rotor and housing cases fills with air, and the vanes, acting as wipers, force air out of the discharge, creating a vacuum in the main pump allowing atmospheric pressure to push water into the hose and into the suction side of the main pump.

A Hale priming pump has a single control that both opens the priming valve between the midship pump and the priming pump and starts the priming motor.

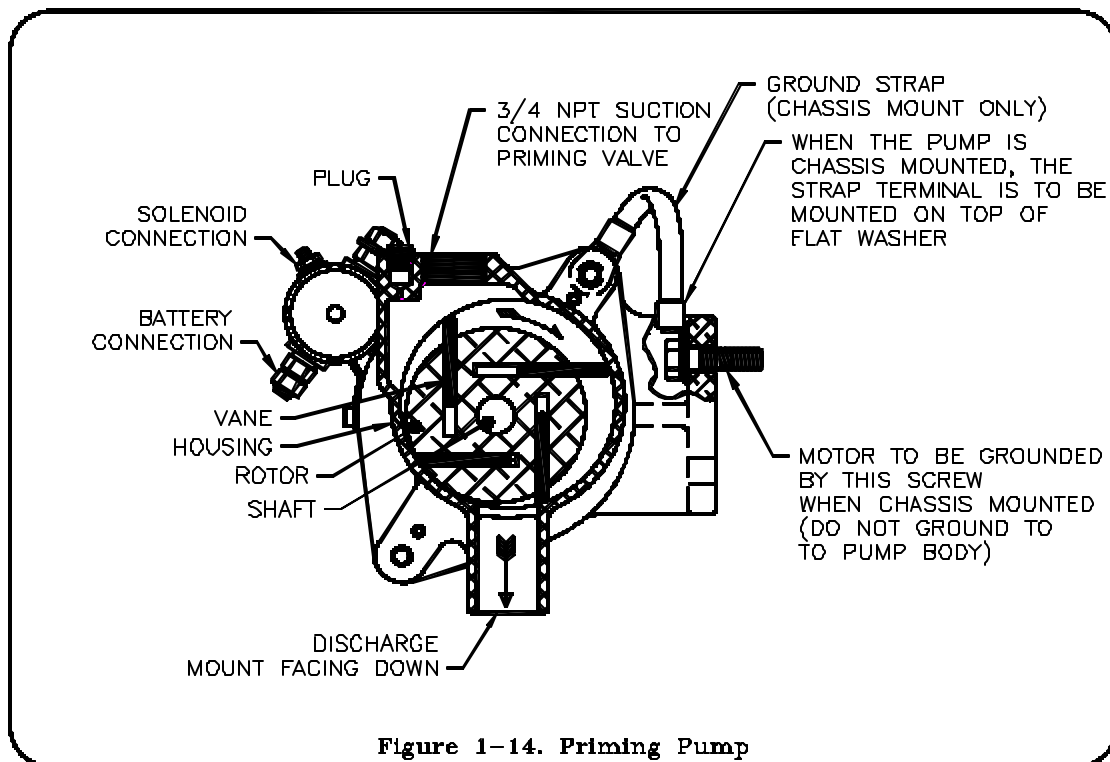

Figure 1-14. Priming Pump

## Priming Valves

Hale priming valves open when the primer is operated, to allow the primer to evacuate air in the pump. There are two priming valves available.

The Hale Semi-Automatic Priming Valve (SPV) can be mounted directly to the priming connection on the midship pump, or can be remotely mounted using a universal mounting adapter. When the SPV is installed, a single electric push-button on the operator's panel starts the priming pump motor. When the primer motor starts and produces a vacuum, the SPV opens. Releasing the push-button stops the priming pump and the SPV closes.

The Hale PVG Priming Valve is mounted on the operator's panel. The PVG is a combination valve and switch. When the panel handle on the PVG is pulled out the valve opens and the switch energizes the primer motor. Pushing the handle de-energizes the motor and closes the valve.

## Pressure Control Devices

Two basic types of pressure control devices are used with Hale Midship pumps:

- ❑ Relief valve system (standard).
- ❑ Hale Total Pressure Master Relief Valve System (optional).

## Relief Valve System

The Hale Standard Relief Valve System is shown in figure 1-15. The relief valve system consists of a panel mounted control valve (PM) and an internal relief valve, either a QG as shown or a QD.

The relief valve system works as follows: The strainer mounted in the pump discharge pressure tap provides pressure to the diaphragm in the PM Control Valve. The handwheel on the PM control either increases or decreases spring tension on the diaphragm. The seat of the QD or QG relief valve is kept closed by pump discharge pressure.

As pump pressure increases, more pressure is applied to the diaphragm in the PM Control Valve. As the pressure on the diaphragm increases beyond the set point, the stem will move off its seat, allowing pump pressure to push on the piston in the relief valve. The pressure on the piston will cause the relief valve seat to lift allowing excess discharge pressure to dump back to the pump suction.

The amber indicator light on the PM control illuminates when the relief valve is open.

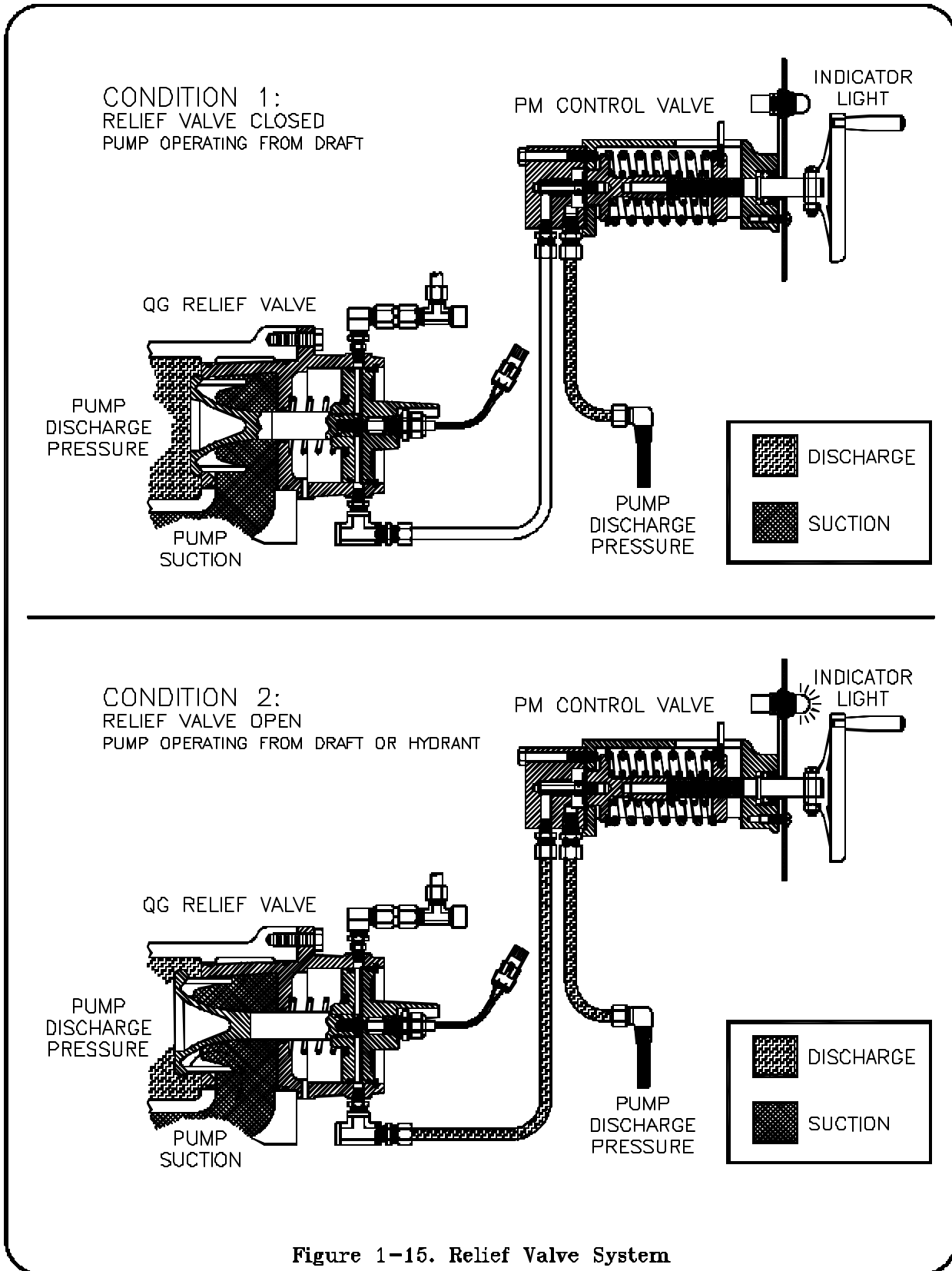

Figure 1-15. Relief Valve System

### Hale Total Pressure Master (TPM) Relief Valve System

This system, figure 1-16, includes a sensing valve connected to the inlet side of the pump that works in conjunction with a Pressure Master Control on the pump panel to give complete control over the entire system. The operating point is set by the Pressure Master Control. Small changes in pump pressure are normally handled internally by the recirculating relief valve (QG). Large changes on either the inlet or discharge side of the pump are controlled by dumping excess pressure to the atmosphere from the discharge side of the pump through the PG30 Relief Valve.

The Hale TPM Relief Valve System is designed to automatically relieve excess pump pressure when operating from draft or positive incoming flows.

The system self-restores to the non-relieving position when excessive pressure is no longer present.

The TPM relief valve system is a mechanical system, consisting of an internal relief valve (QG) which bypasses water to the suction side of the pump, an external relief (dump) valve (PG30, with sensing valve attached) to discharge water to the atmosphere, and a single panel mounted control valve (PMD) to provide control of pump pressure, within NFPA required limits, to the pump operator.

The PMD control permits the pump operator to “set” a desired relief pressure for both internal and external relief valves. The panel control has an easy to read and easy to set adjustment with an approximate indication of pressure setting.

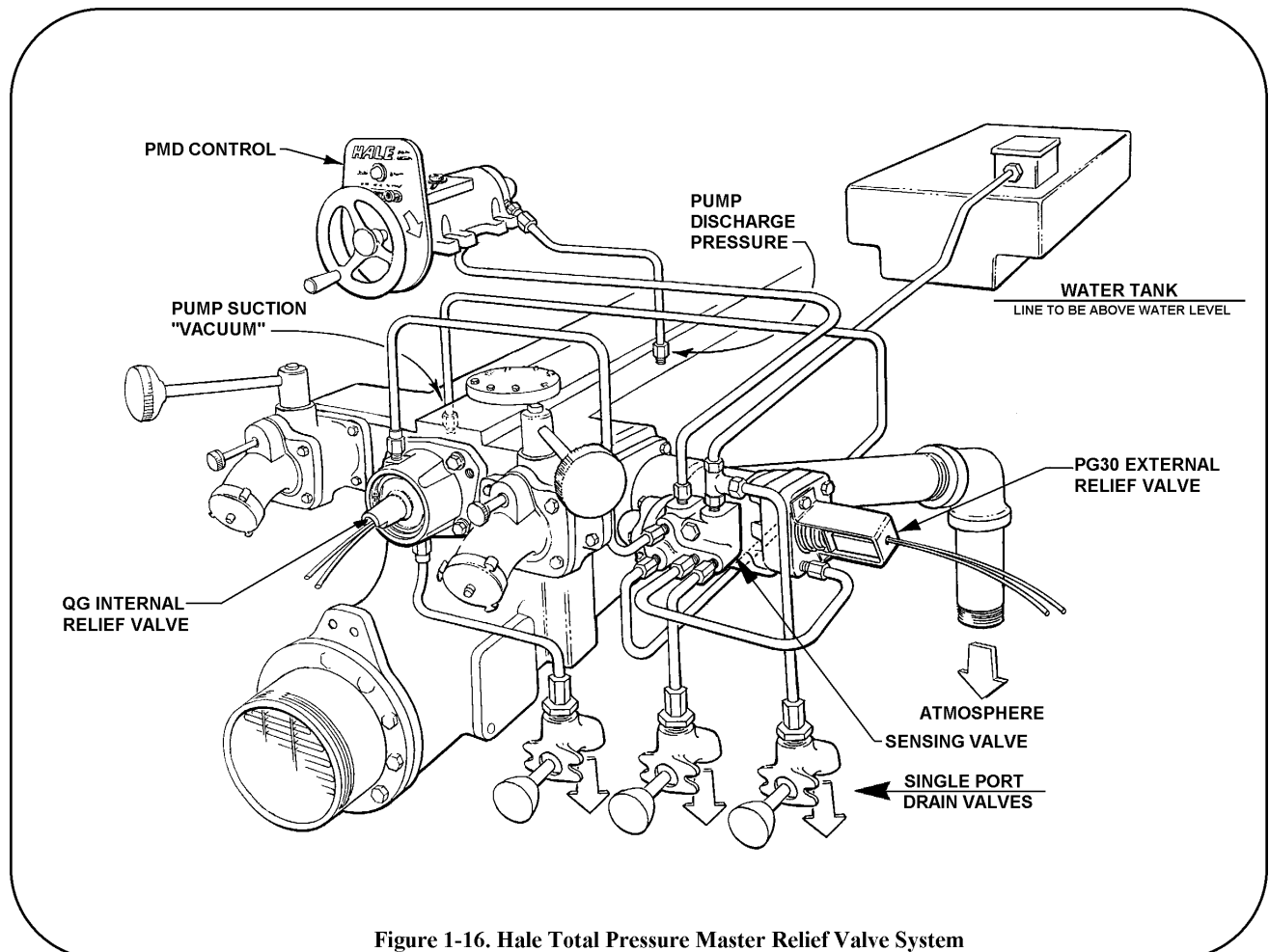

Figure 1-16. Hale Total Pressure Master Relief Valve System





During normal operation, both the QG relief valve and PG30 relief valve are closed (as shown in figure 1-17).

The TPM system functions by monitoring and controlling pump pressure and relieves excessive pressure by first utilizing the internal relief valve (QG) (returning flow to the pump suction, see figure 1-18). If excessive pressure remains and there is positive pressure on the suction, a secondary external relief valve (PG30) responds by discharging excessive pressure to the atmosphere (shown in figure 1-19). The staging of the internal and external relief valves to operate in series ensures maximum protection against over pressure and eliminates the indiscriminate discharging of water to the ground.

The external relief valve (PG30) is mounted on the discharge side of the pump where discharged water flowing through the valve provides a self-cleaning process and virtually eliminates the possibility of the valve remaining in an open position due to contamination.

The amber light on the PMD control illuminates when the QG relief valve is open. The same light flashes when both the QG and PG30 valves are open.

**Condition 1:**  
**All Relief Valves Closed**  
 Pump Operating From Draft

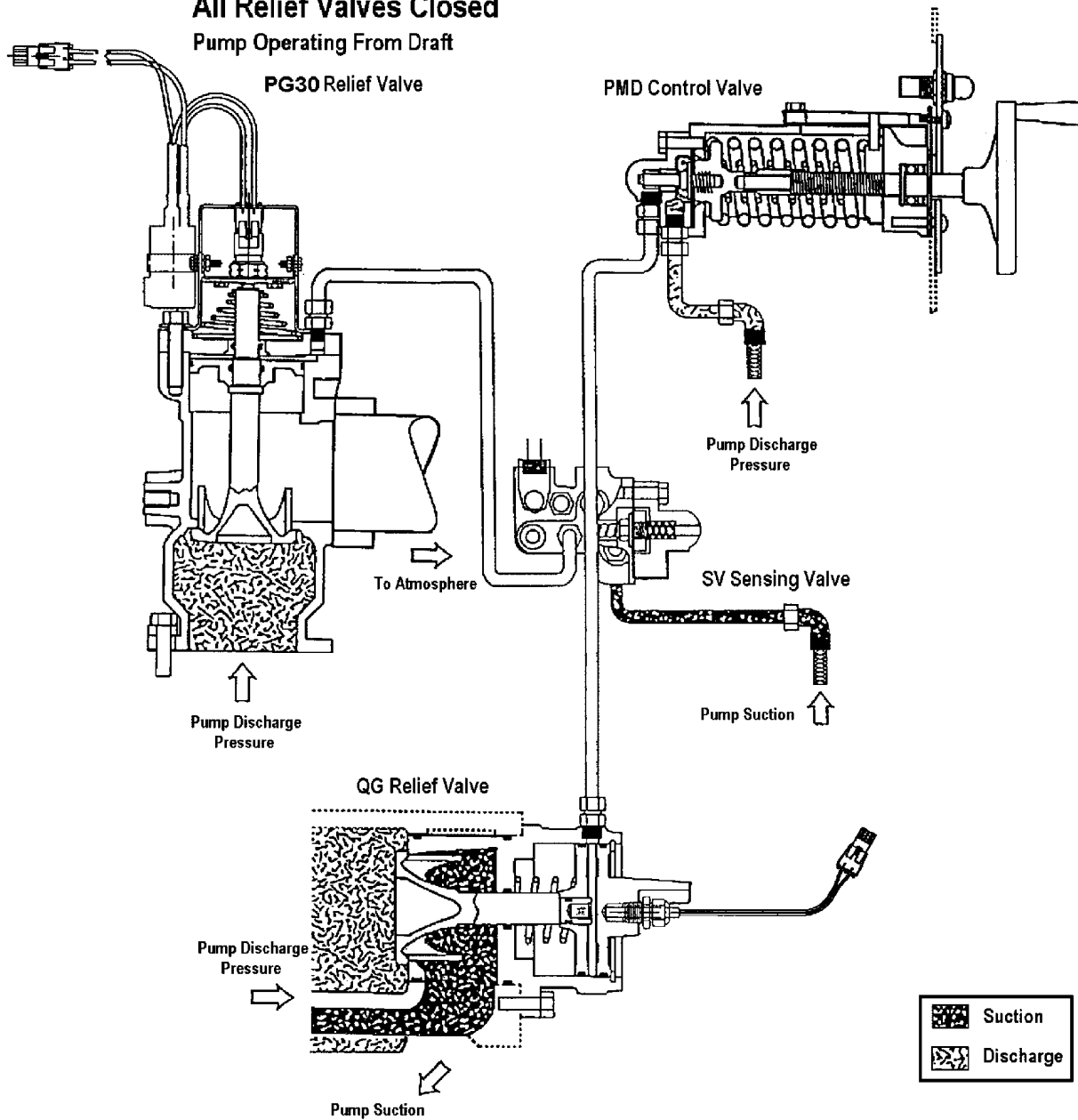
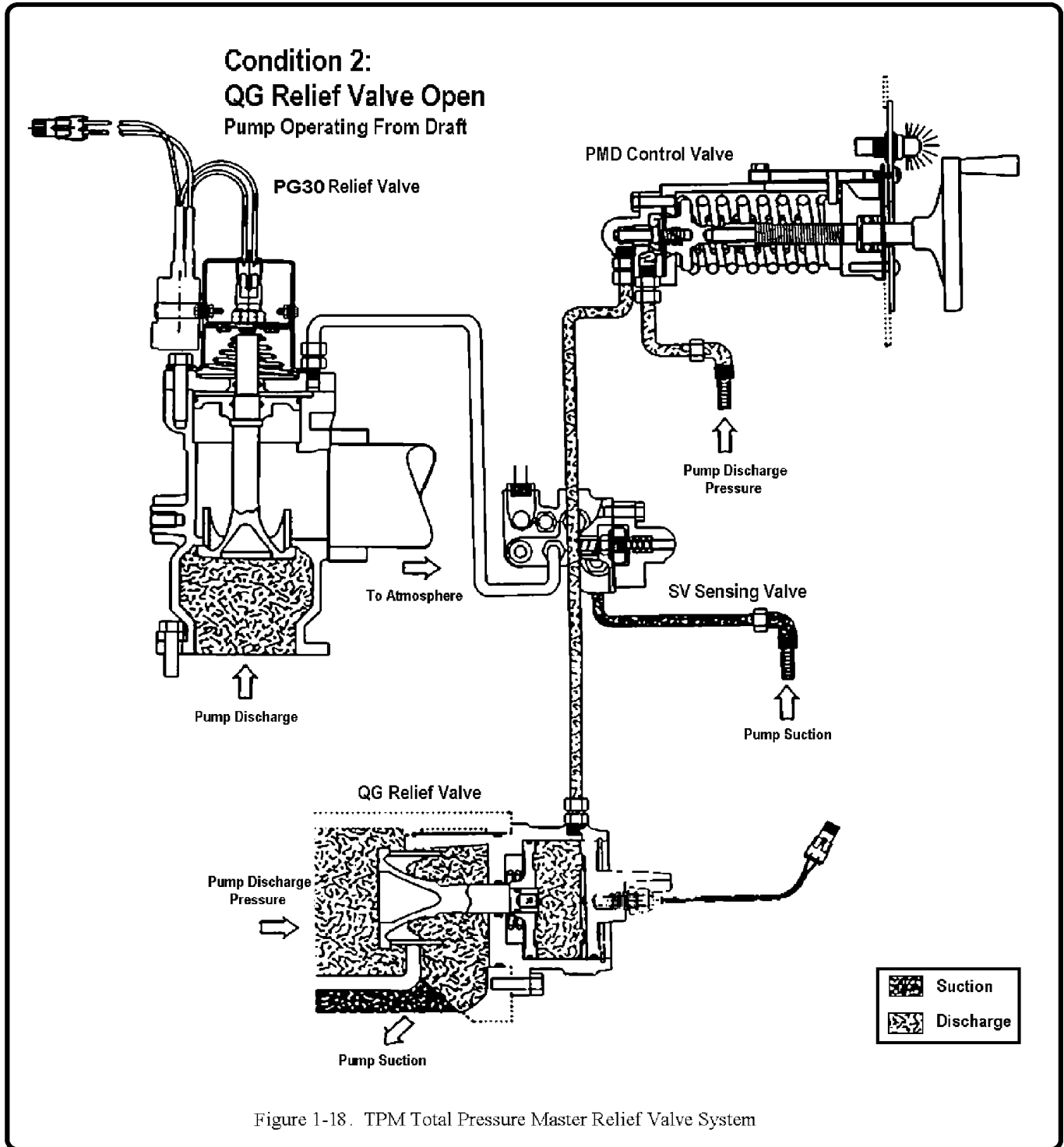

Figure 1-17. TPM Total Pressure Master Relief Valve System



**Condition 3:  
QG and PG30 Relief Valves Open**  
Pump Operating with Positive Suction  
Pressure (Hydrant)

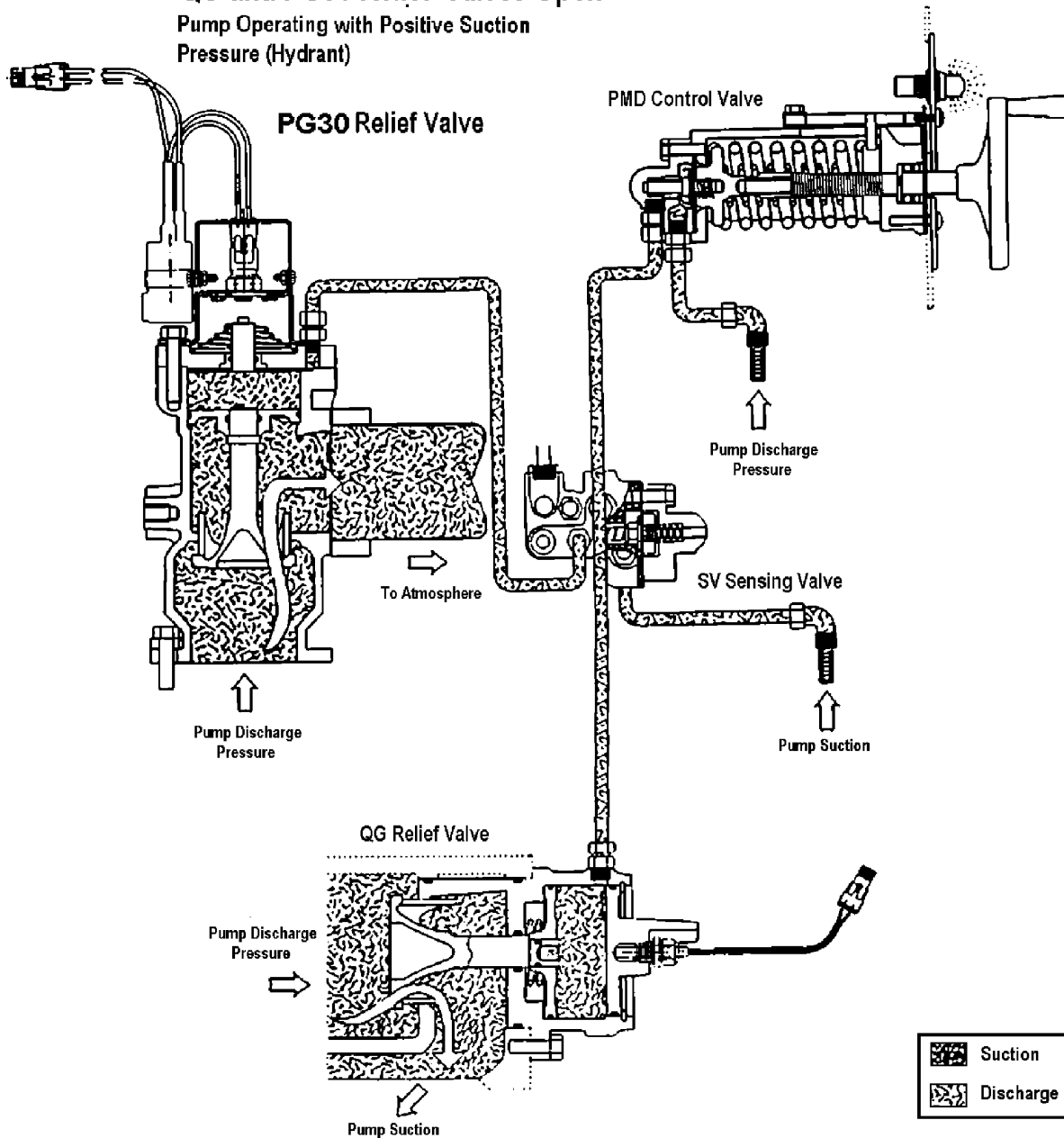

Figure 1-19. TPM Total Pressure Master Relief Valve System

Cooling Options

Model K Auxiliary Heat Exchanger/Cooler

NFPA 1901 requires a supplementary heat exchanger cooling system for the pump drive engine during pumping operations. Hale model "K" heat exchangers, figure 1-20, meet NFPA 1901 requirements. The units can be used with any size radiator and use water from the pump to help maintain the proper temperature of the engine coolant during pumping. The cast-iron housing and copper-tubing coil keeps the water and coolant from contaminating each other. A valve is normally supplied on the operator's panel to allow the operator to control the amount of water supplied to the model "K" heat exchanger.

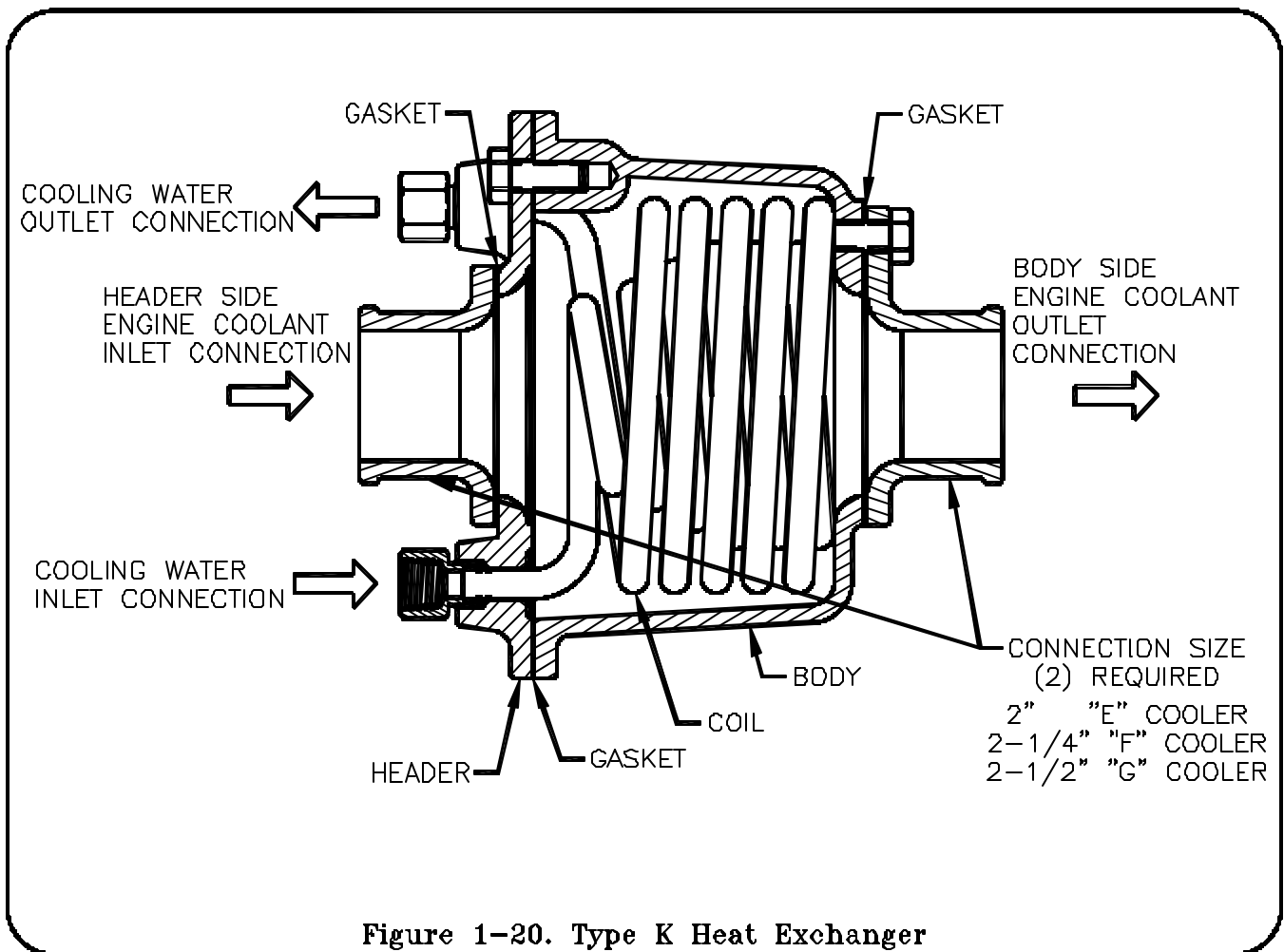

Figure 1-20. Type K Heat Exchanger

**Thermal Relief Valve (TRV)**

An optional Thermal Relief Valve (TRV), figure 1-21, can be attached to the main pump body. This valve prevents the overheating of the pump under certain operating conditions. The valve monitors and controls the temperature of the water in the pump. When the temperature exceeds 120°F, the valve automatically opens and discharges a small amount of water either to the ground or into the water tank, allowing cooler water to enter the pump. After the temperature reduces to a safe level, the valve closes until the temperature is exceeded again.

The TRV-L model includes a chrome panel placard with warning lamp and lamp test button, and a preassembled wiring harness. The light illuminates whenever the TRV is open and discharging water. An optional buzzer provides audible warning. The buzzer mounts in a 1-1/8 inch opening on pump panel.

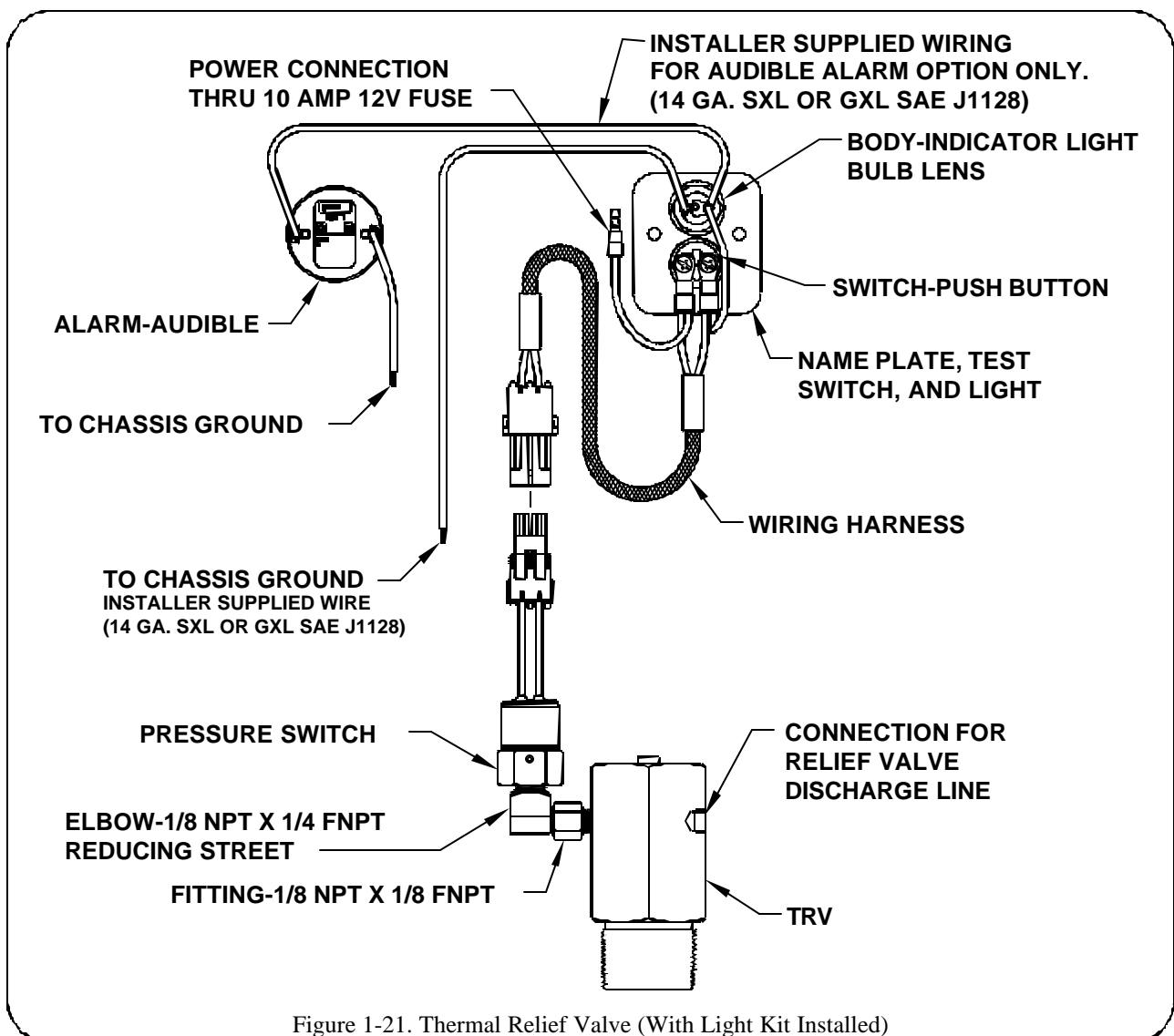

Figure 1-21. Thermal Relief Valve (With Light Kit Installed)

## Valves

### Suction Valves

Hale has available valves that mount in the suction of the midship pump.

The Hale Master Intake Valve (MIV) becomes an integral part of the fire pump. When the valve is ordered as part of a Hale Midship fire pump, the pump will pass UL requirements up to 1500 GPM (5678 LPM) from draft through a single 6 inch NST suction hose with the valve in place. When two valves are mounted to the fire pump the pump can achieve NFPA Performance Point flows of 2000 GPM (7580 LPM) from draft with dual 6 inch NST suction hoses. NFPA Performance Point flows of 2250 GPM (8516 LPM) is achieved with two MIVs and three 6 inch NST suction hoses. The Hale MIV meets NFPA requirements for operations using a large diameter supply hose. See

figure 1-22 for Master Intake Valve. Further information on the MIV can be found in manual P/N 029-0020-35-0.

At least one full flow suction valve with locking handle is normally mounted on the pump. The body of each suction valve connects into the pump suction with a maximum of one long sweep 90° elbow between the valve and the pump suction.

### Discharge Valves

Discharge valves regulate the amount of water leaving a pump. Each valve includes a locking device that permits operation in any position from fully opened to fully closed. The 2-1/2-inch discharge valves are quarter-turn ball-type with a locking handle. As the valve handle is moved the ball can rotate from being in-line with the waterway to a position 90° to the waterway, or any position in between, thus reducing or stopping the flow of water. In-line valves are also quarter-turn ball-type valves.

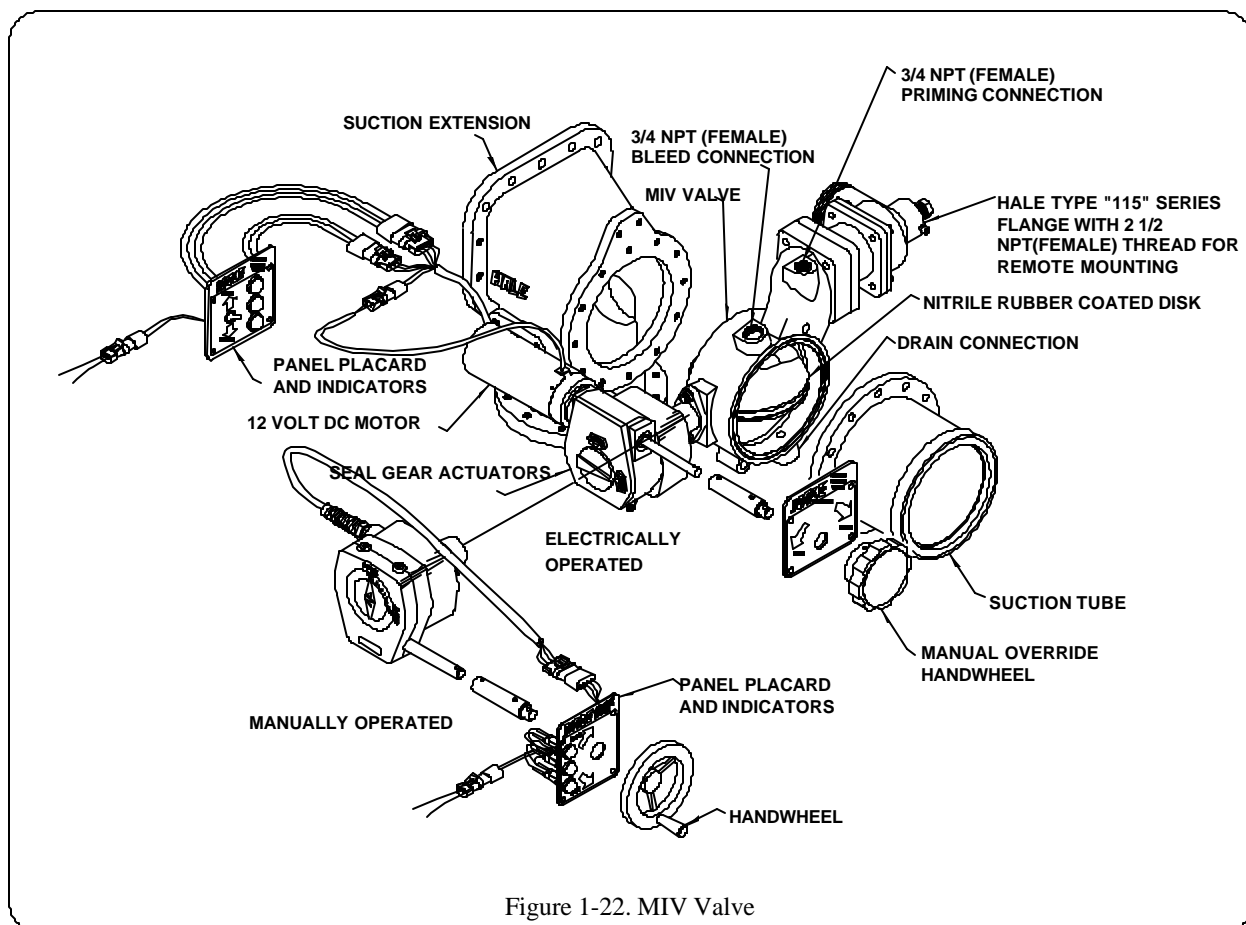

Figure 1-22. MIV Valve

These valves can be used in either suction or discharge lines.

Each discharge valve on a Hale pump may be equipped with a drain. Opening the drain before uncoupling the hose relieves the pressure in the line. Also, water must be drained from the pump during freezing conditions through the main drain valve.

### Tank Suction Valves

There are two different Hale valves that can be used as tank suction.

The first valve is the Hale 30BPF, this valve is an integral flanged valve that mounts to the 8-bolt flange pattern at the tank suction port of the midship pump. The valve is a lever operated 3-inch full flow ball valve and can be connected to the tank using a 4-inch Victualic™ coupling or 3 inch NPT pipefitting or a 4 inch hose.

Another option for the tank suction valve, is the 40BDS Model valve. The 40BDS valve is a 4-inch full flow ball valve that is available lever operated or can be equipped with an electric motor gear operator. The nature of the 40BDS permits mounting to the tank suction opening on the pump using an 8-bolt 3.5° angled flange or an 8-bolt straight flange. Tank connection is by use of 4 inch NPT threaded pipe fittings or 4 inch or 5 inch Victualic™ clamps.

The 30BPF and 40BDS valves are provided with an optional check valve flapper to prevent pressurization of the water tank.

### In-line Valves

Hale has several types, sizes, manual, and electrically operated in-line valves. The BP series-bronze valves range in size from one inch to three inch in half-inch increments.

Hale type 40BD 4 inch in-line valves have many options:

- ❑ Manual gear operator (see figure 1-24).
- ❑ Electric gear operator with optional manual override (see figure 1-25).

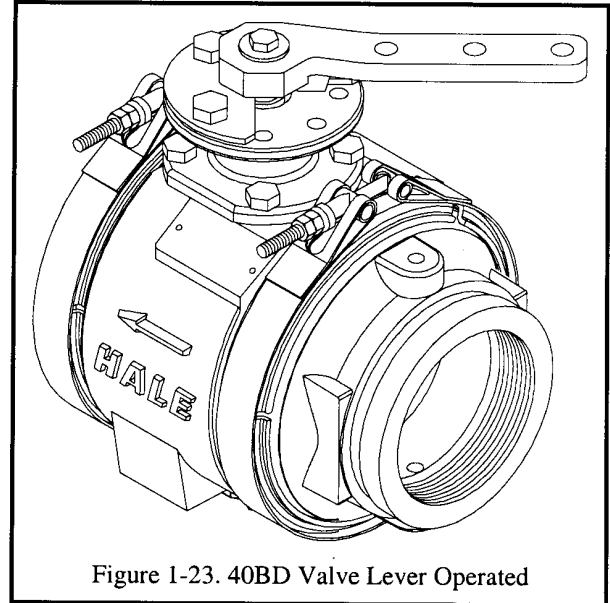

Figure 1-23. 40BD Valve Lever Operated

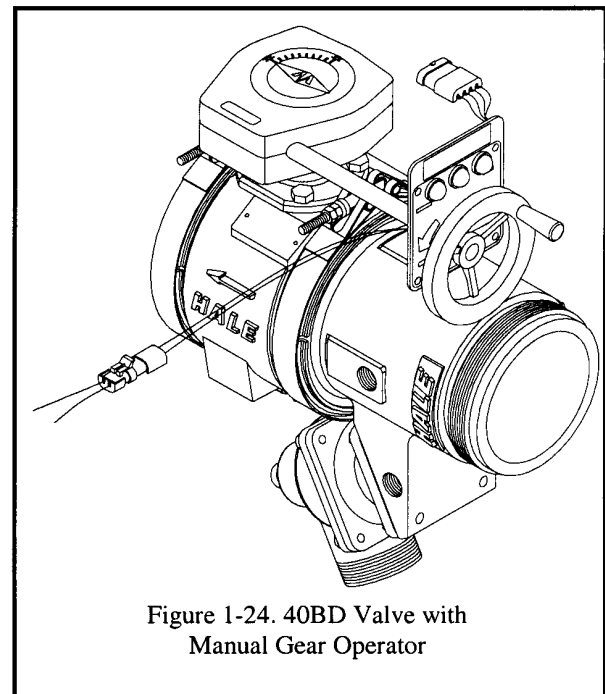

Figure 1-24. 40BD Valve with Manual Gear Operator

- ❑ Inlet and outlet sizes.
- ❑ Lever operated for tank and suction line (see figure 1-23).
- ❑ Direct mount (Deck Gun) valve.



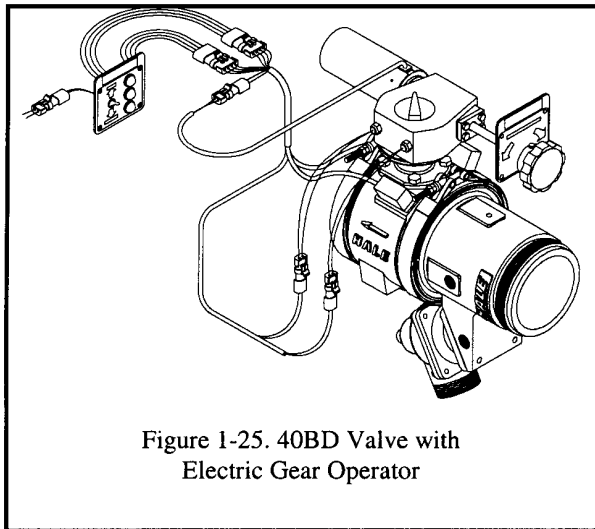

Figure 1-25. 40BD Valve with Electric Gear Operator

### Drain Valves

There are two types of drain valves available from Hale. They are either the sliding plug type (HD, DV5) or a screw knob style (DV7).

The sliding plug type valves have a pull handle mounted on the operator's panel. Pulling the handle out opens the valve allowing the component to drain. The Model DV5 has connections for up to five drain lines. When the DV5 is either open or closed, the possibility for "cross talk" exists. This drain valve cannot be used with either relief valves or other pilot pressure valves. The screw knob style drain valve (DV7) has facilities to connect up to seven individual drain lines. Each connection to the DV7 is individual and the possibility for "cross talk" does not exist. The control knob is located on the operator's panel. Turning the control knob counterclockwise will open the drain valve.

### Anodes

The Hale Anode System helps prevent damage caused by galvanic corrosion within the pump. Galvanic action pits the pump and pump shaft material through the electrolysis of water in the pump. The popularity of non-corrosive water tanks and piping has increased the incidences of this type of corrosion in today's fire pumps. The Hale Anode System provides a sacrificial metal, which helps to diminish or prevent pump and pump shaft galvanic corrosion. The Hale Anode will fit on any Hale truck mounted pump, regardless of age or model. It is designed to be easily installed requiring just four bolts and a gasket. Total time to install is just fifteen minutes, yet it will provide years of protection for your pump. The Anode kit (figure 1-26) is designed for installation in the standard Hale 115 series flange openings. On fabricated manifolds and similar applications, the installer is to provide 1-1/4 NPT openings and install anodes directly. It is recommended that one anode is installed on the suction side and one is installed on the discharge side. Anodes can be mounted in any position (horizontal or vertical).

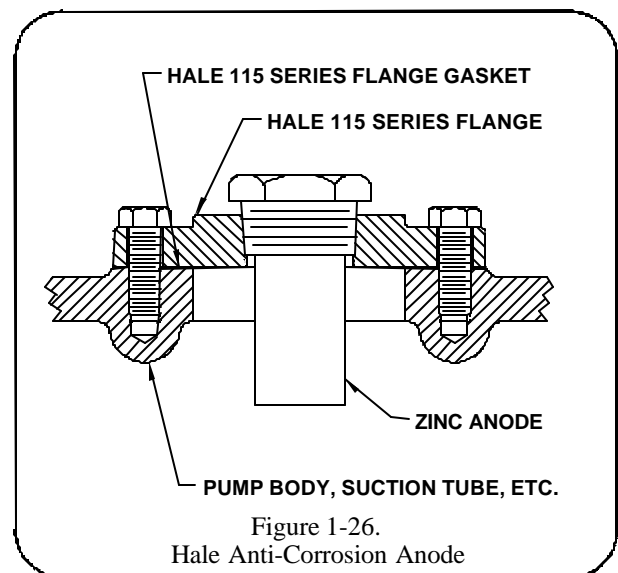
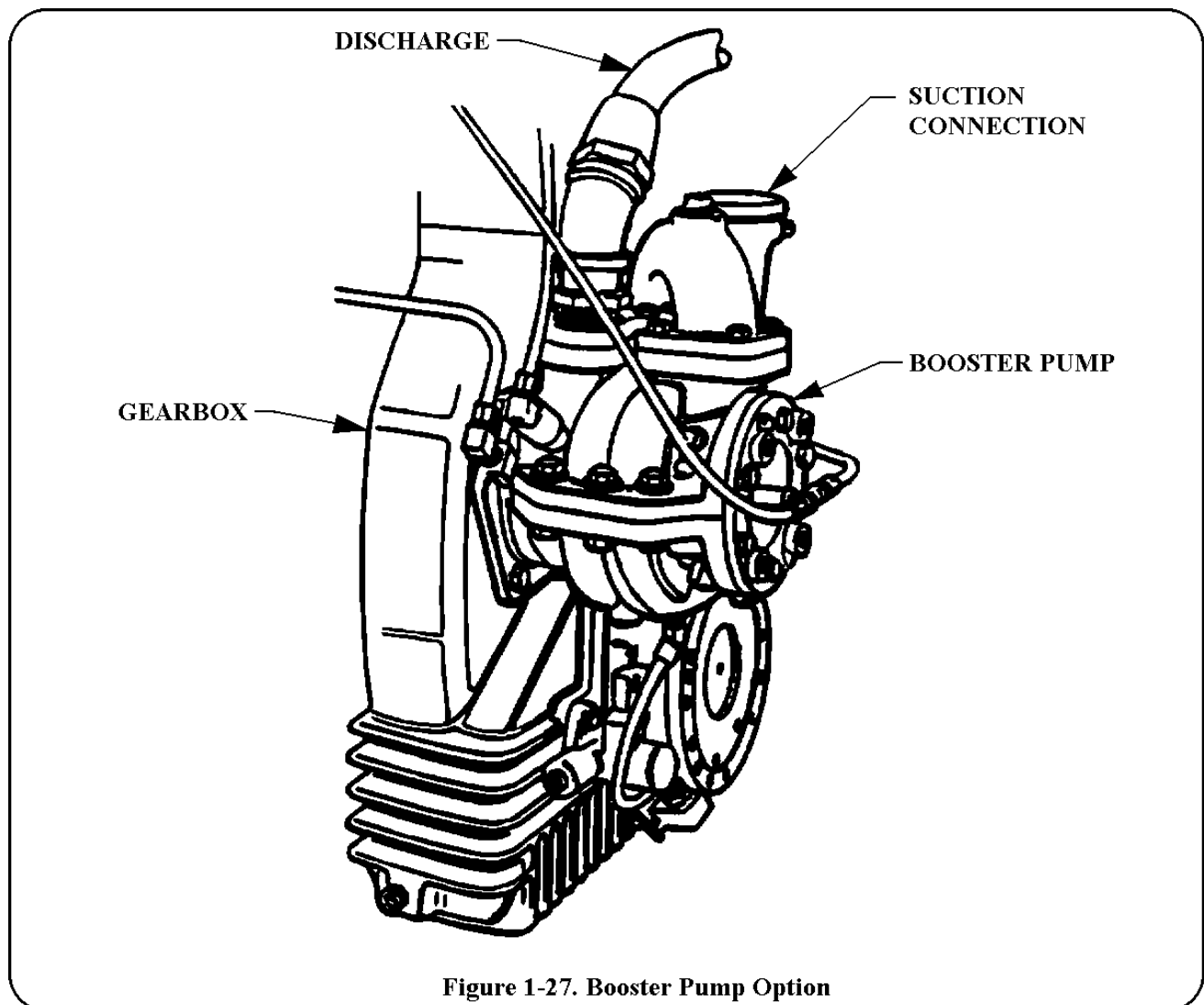

Figure 1-26.  
Hale Anti-Corrosion Anode

## Booster Pump

Hale booster pumps offer the added dimension of low volume and high pressure for use with the midship pumps. The booster is ideal for high pressure, hose reel operation.

As shown in figure 1-27, the booster pump is designed for direct mounting at the accessory port of the Hale "L" series gearbox. The booster pump is driven by the gearbox intermediate gear to provide a positive drive. Water is directed to the booster pump through a pre-piped supply hose.





## 2. OPERATING PROCEDURES

### A. Overview

This section supplies information and procedures for the operation of Hale single-stage and two-stage pumps. Included in this section are procedures for pumping from a hydrant, pumping from draft, pumping from a booster tank, pumping in relay, tandem pumping from a hydrant, and post-operation procedures.

### B. Operating Procedures

THE PROCEDURES IN THIS SECTION ARE GENERAL OPERATING PROCEDURES. THEY DO NOT REPLACE THE PROCEDURES AND POLICIES ESTABLISHED BY YOUR FIRE DEPARTMENT, NOR DO THEY REPLACE THE RECOMMENDATIONS AND PROCEDURES PROVIDED BY THE FIRE TRUCK MANUAL.

#### Pumping From a Hydrant, General Operation

1. Position the truck for the best hydrant hookup and discharge hose layout.

#### NOTICE

REFER TO THE FIRE DEPARTMENT PROCEDURES ON SETTING WHEEL CHOCKS AS WELL AS LAY OUT AND CONNECTION OF SUCTION AND DISCHARGE HOSES.

ALL VALVES, DRAIN COCKS, AND CAPS SHOULD BE CLOSED.

#### CAUTION

NEVER ATTEMPT TO SHIFT THE PUMP TRANSMISSION WHILE THE TRUCK TRANSMISSION IS IN GEAR. ALWAYS SWITCH THE TRANSMISSION TO “N” AND VERIFY THE SPEEDOMETER IS “0” BEFORE MAKING PUMP TRANSMISSION SHIFT.

2. Bring the truck to a complete stop before you attempt to shift from road to pump.
3. Apply the truck parking brake.
4. Shift the truck transmission to the NEUTRAL position.
5. Move the in-cab pump shift control valve from the ROAD position to the PUMP position. The shift warning lights should come on in a second or two, indicating a complete shift.

If the truck manufacturer has used another in-cab valve to achieve pump shift or has an electric switch, follow the instructions supplied with that valve.

6. After pump shift is completed, put the truck transmission in the proper pump operating range or gear. For most pumpers this will be direct drive (1:1) ratio. In addition, the speedometer should read 5 to 15 MPH after the shift has been completed. If the shift does not seem to be completed, shift truck transmission to “N” and repeat the entire procedure. Note that some vehicles drive the speedometer from the front wheel of the chassis. In this case, the speedometer will not read 5 to 15 MPH after shifting to the pump position. See the chassis manual for details.

#### WARNING

DO NOT LEAVE THE CAB OR ATTEMPT TO PUMP UNTIL ALL THE GREEN PUMP LIGHTS IN THE CAB AND PANEL ARE ON.

7. Exit the driving compartment only after all the above steps are completed and you are sure that the shift completed lights in the cab and panel are on.

#### WARNING

DO NOT OPEN THROTTLE UNLESS ALL GREEN PUMP INDICATOR LIGHTS ARE ON.



8. Verify that the pump panel shift indicator green "OK TO PUMP" light is on.
9. Open the hydrant.
10. If necessary, open the suction valve.
11. If applicable, set the transfer valve to either *volume* or *pressure*, as required.
12. If necessary to eliminate air pockets open valve to let air out or prime the pump: see "Pumping From Draft" for instructions.
13. Note the intake and discharge pressures then open the engine throttle gradually until the master discharge gauge indicates the desired pressure.
14. Set the automatic relief valve according to your fire department policy. If your fire department does not have a policy to follow, see the "Relief Valve or TPM Procedures" later in this section

 **CAUTION**

DO NOT REDUCE THE PRESSURE ON THE INTAKE GAUGE TO ZERO; SERIOUS DAMAGE TO THE WATER MAIN COULD RESULT.

If the master intake gauge shows a vacuum before the desired discharge pressure or flow is reached, this is an indication that you are getting all the water that the hydrant will supply. To increase the pressure when this occurs, reduce the pump flow. The master intake gauge reading must be maintained at 5 PSI (.5 BAR), minimum.

As the throttle is opened, the pressure gauge reading increases with the engine speed. If the engine speed increases without an increase in pressure, the pump may be cavitating. In this case, close the throttle slowly until the pressure begins to drop, and the engine returns to an idle. If this does not correct the problem you are trying to pump more capacity than is available from the hydrant.

15. Open the discharge valves.
16. If the pump overheats and is not equipped with the Hale TRV valve, open the valve to access

the pump auxiliary cooling system, or slightly open the tank fill line.

17. After completion of pumping procedures, gradually reduce the pump pressure until the engine is at an idle speed. Use the "Pump to Road Shift Procedure" and "Post Operation Procedure" provided later in this section.

**TPM Operation from a Hydrant**

When operating from a positive inlet pressure, during some operational conditions, it may be necessary to adjust the TPM Relief Valve to a point where water is dumping to the ground. The internal relief valve will always open first, and if it cannot handle the pressure rise, the external relief valve will dump water on the ground. When the internal relief valve opens, the panel light will be on, and when the external dump valve opens, the pilot light on the panel will flash.

**Pumping From Draft, General Operation.**

1. Get as close to the water source as possible. The pump can do better than its rated capacity with less than a 10-foot vertical lift. As the vertical lift increases to above 10 feet, the maximum pump capacity will be reduced.

**NOTICE**

REFER TO THE FIRE DEPARTMENT PROCEDURES IN SETTING WHEEL CHOCKS AS WELL AS LAY OUT AND CONNECTION OF SUCTION AND DISCHARGE HOSES.

ALL VALVES, DRAIN COCKS, AND CAPS SHOULD BE CLOSED.

 **CAUTION**

NEVER ATTEMPT TO SHIFT THE PUMP TRANSMISSION WHILE THE TRUCK TRANSMISSION IS IN GEAR. ALWAYS SWITCH THE TRANSMISSION TO "N" AND VERIFY THE SPEEDOMETER IS "0" BEFORE MAKING PUMP TRANSMISSION SHIFT.



2. Bring the truck to a complete stop before you attempt to connect suction hoses or shift from road to pump.
3. Apply the truck parking brake.
4. Shift the truck transmission to the NEUTRAL position.
5. Move the in-cab pump shift control valve from the ROAD to the PUMP position. The shift warning light should come on in a second or two, indicating a completed shift. If the truck manufacturer has used another in-cab valve to achieve pump shift, follow the instructions supplied with that valve
6. After pump shift is complete, put the truck transmission in the proper pump operating range or gear. For most pumpers this will be direct drive (1:1) ratio. In addition, the speedometer should read 5 to 15 MPH after the shift has been completed. If the shift does not seem to be completed, shift truck transmission to "N" and repeat the entire procedure. Note that some vehicles drive the speedometer from the front wheel of the chassis. In this case, the speedometer will not read 5 to 15 MPH after shifting to the pump position. See the chassis manual for details.

 **WARNING**

DO NOT LEAVE THE CAB OR ATTEMPT TO PUMP UNTIL ALL THE GREEN PUMP LIGHTS IN THE CAB AND PANEL ARE ON.

7. Exit the driving compartment only after all the above steps are completed and you are sure that the shift completed lights in the cab and panel are on.

 **WARNING**

DO NOT OPEN THROTTLE UNLESS ALL GREEN PUMP INDICATOR LIGHTS ARE ON.

8. Verify that the pump shift indicator light is on.

9. Activate the priming pump by pulling the control handle located on the pump panel or depressing the push button.

The departmental manual for pumping should specify the correct RPM for priming, but in general, for priming the pump should be operated at idle with an engine speed of about 1,000 to 1,200 RPM.

10. Watch the intake and discharge master gauges. When the pump is primed, the intake indication reading falls below zero, and the discharge pressure starts to increase. You may also hear water discharging on the ground, indicating that the pump is primed.

Running the engine at speeds higher than 1,200 RPM during priming is not recommended, because it will not improve priming operation. Running the pump at higher RPM will increase wear.

 **CAUTION**

IF THE DISCHARGE GAUGE READING DOES NOT INCREASE, THE INTAKE GAUGE READING DOES NOT FALL BELOW ZERO, OR THE PRIMING PUMP DOES NOT DISCHARGE WATER ON THE GROUND IN 30 SECONDS, DO NOT CONTINUE TO RUN THE PRIMING PUMP. STOP THE PUMP, AND CHECK FOR AIR LEAKS OR POSSIBLE PUMP TROUBLE.

11. After priming, select the desired transfer valve position (for two-stage pumps).
12. Gradually open the discharge valve until the water emerges as a steady stream. Then open the other discharge valves to the desired setting.
13. Open the engine throttle gradually until the desired pressure or flow is reached.

**⚠ CAUTION**

DO NOT PUMP ENOUGH WATER TO CAUSE A WHIRLPOOL AT THE STRAINER. THIS ALLOWS AIR INTO THE PUMP, RESULTING IN ROUGH OPERATION AND PULSATION. REPOSITION THE STRAINER OR REDUCE FLOW TO CORRECT THE SITUATION.

As the throttle is opened, the pressure gauge reading increases with the engine speed. If the engine speed increases without an increase in pressure, the pump may be cavitating.

If the pump is cavitating, warn personnel that the pressure is being dropped. In this case, close the throttle slowly until the pressure begins to drop, and the engine returns to an idle. If this does not correct the problem, here are two possibilities that can also lead to this condition:

- a. Cavitation can occur with large nozzle tips. Solve this problem by reducing flow.
  - b. Cavitation can also occur when you are pumping if air enters with the water. Even though the pump may be primed, air leaks can cause rough operation and an increase of engine speed without an increase in pressure or flow. If an air leak is suspected, discontinue pumping and refer to Section 4 for maintenance.
14. If a pump shutdown is desired while pumping from draft, reduce the engine speed to idle, and close the discharge valves. To resume pumping, open the throttle and discharge valves. If the pump overheats from continued churning without water flow, open the discharge valves periodically to release hot water.
  15. Set the automatic relief valve according to your fire department policy. If your fire department does not have a policy to follow, see the “TPM or Relief Valve Procedures” later in this section.
  16. If the pump overheats and is not equipped with the Hale TRV valve, open the valve to access the pump auxiliary cooling system, or slightly open the tank fill line.

17. After completion of pumping procedures, gradually reduce the engine RPM until it is at an idle speed. Use the “Pump to Road Shift Procedure” and “Post Operation Procedure” provided later in this section.

**Pumping From the Onboard Water Tank**

1. Position the truck for convenient discharge hose layout, and bring the truck to a complete stop.

**NOTICE**

REFER TO THE FIRE DEPARTMENT PROCEDURES ON SETTING WHEEL CHOCKS AS WELL AS LAY OUT AND CONNECTION OF SUCTION AND DISCHARGE HOSES.

2. Bring the truck to a complete stop before you attempt to shift from road to pump.
3. Apply the truck parking brake.
4. Shift the truck transmission to the NEUTRAL position.
5. Move the in-cab pump shift control valve from the ROAD position to the PUMP position. The shift warning light should come on in a second or two, indicating a completed shift. If the truck manufacturer has used another in-cab valve to achieve pump shift, follow the instructions supplied with that valve.
6. After pump shift is complete, put the truck transmission in the proper pump operating range or gear. For most pumps this will be direct drive (1:1) ratio. In addition, the speedometer should read 5 to 15 MPH after the shift has been completed. If the shift does not seem to be completed, shift truck transmission to “N” and repeat the entire procedure. Note that some vehicles drive the speedometer from the front wheel of the chassis. In this case, the speedometer will not read 5 to 15 MPH after shifting to the pump position. See the chassis manual for details.



**⚠ WARNING**

DO NOT LEAVE THE CAB OR ATTEMPT TO PUMP UNTIL ALL THE GREEN PUMP LIGHTS IN THE CAB AND PANEL ARE ON.

- Exit the driving compartment only after all the above steps are completed and you are sure that the shift completed warning lights in the cab and panel are on.

**⚠ WARNING**

DO NOT OPEN THROTTLE UNLESS ALL GREEN PUMP INDICATOR LIGHTS ARE ON.

- Verify that the pump panel shift indicator light is on.
- Open the tank suction valve.
- For two-stage pumps, select the desired transfer valve position.
- Check the master discharge gauge to see if priming is necessary. If necessary, start the priming pump by pulling the control handle located on the pump panel or depressing the prime push button or just crack the tank fill valve.

**⚠ CAUTION**

IF THE DISCHARGE GAUGE READING DOES NOT INCREASE, THE INTAKE GAUGE READING DOES NOT FALL BELOW ZERO, OR THE PRIMING PUMP DOES NOT DISCHARGE WATER ON THE GROUND IN 30 SECONDS, DO NOT CONTINUE TO RUN THE PRIMING PUMP. STOP THE PUMP, AND CHECK FOR AIR LEAKS OR POSSIBLE PUMP TROUBLE.

Watch the intake and discharge pressure gauges. When the pump is primed, the compound gauge indication falls below zero, and the pressure starts to increase. You may also hear water splashing on the ground, indicating that the pump is primed.

- Open the engine throttle gradually until the desired pressure or flow is reached. As the throttle is opened, the discharge pressure gauge reading increases with the engine speed. If the engine speed increases without an increase in pressure, the pump may be cavitating.

If the pump is cavitating, warn personnel that the pressure is being dropped. In this case, close the throttle slowly until the pressure begins to drop, and the engine returns to an idle. If this does not correct the problem, reduce flow.

**⚠ WARNING**

DO NOT OPEN THROTTLE UNLESS ALL GREEN PUMP INDICATOR LIGHTS ARE ON.

- Gradually open the discharge valves until the water emerges as a steady stream. Then open the discharge valves to the desired setting.
- Set the automatic relief valve according to your fire department policy. If your fire department does not have a policy to follow, see the “TPM or Relief Valve Procedures” later in this section.
- If the pump overheats and is not equipped with the Hale TRV valve, open the valve to access the pump auxiliary cooling system, or slightly open the tank fill line.
- After completion of pumping procedures, gradually reduce the engine RPM until it is at an idle speed. Use the “Pump to Road Shift Procedure” and “Post Operation Procedure” provided later in this section.

**Pumping In Relay**

Relay operations are necessary when the water source is too far away from the fire to be pumped efficiently by one pumper. Relay pumping is the movement of water through a number of consecutive pumpers, from suction to discharge. The number of pumpers is determined by how far the water source is from the fire.

In some cases, when you are on the receiving end of a relay, it may help to set the suction dump or



TPM (if available) very low in order to limit the incoming pump pressure by dumping water on the ground before you have discharge hose lines connected and are flowing water. Then, as you are able to use the incoming water, the relief valve control can be moved up to the desired operating pressure and set as instructed. This technique will also help you to purge the air from the incoming hose and the pump before it can get to a dangerously high pressure.

Use this procedure after the hose is laid, the apparatus are in position, and the pumps are engaged. See the “Pumping from a Hydrant” procedure for setup and engagement instructions for apparatus receiving pressurized water.

1. Open two discharge gates on all pumps, except on the pump at the source, to get rid of air from hose lines and pumps.
2. On each pump, attach the hose lines to one of the discharges, and leave the other discharge uncapped (only for trucks without a relay valve).
3. Watch the intake gauge for a high-pressure reading. If this is reached, open the gate controlling the uncapped discharge to remove excess water.
4. Supply the pump at the water source with water; prime if necessary. The discharge pressure must not be over 150 PSI (10 BAR) or the maximum pressure rating of the relay hose to start water moving. Use either the “Pumping From Hydrant” or “Pumping From Draft” procedures that appear earlier in this section.
5. When the water reaches the second pump, close the uncapped discharge gate. Repeat this step for all pumps until the water reaches the fire ground.
6. Adjust the throttle on the pump at the water source for the required operating pressure. Watch the gauges to avoid cavitation. (The pump operator at the fire scene will advise all other pump operators of the amount of water needed at the fire ground).
7. Adjust the discharge pressure or flow at the fire scene to supply the lines being used.
8. Observe the gauges carefully, and adjust the pressure or flow as needed.
9. Shutdown starts from the fire ground pump and works toward the water source. Gradually reduce pressure at the fire ground pump until you can disengage it. Follow this procedure for every pump in the relay until the pump at the water source is shut down.

**NOTICE**

LOCAL TRAINING PROCEDURES MAY VARY SLIGHTLY FROM ABOVE.

**Tandem Pumping Operation From a Hydrant**

1. Using the large intake hose, connect the first pumper to the hydrant steamer. Open the hydrant until the pump is primed, then partially close the hydrant.
2. Position the second pumper intake-to-intake with the first pumper.
3. Open a discharge to flow water.
4. With the hydrant partially closed, adjust the throttle on the first pumper until the intake gauge reads about 5 PSI (.5 BAR)
5. Remove the unused intake cap.
6. Connect the second pumper to the unused steamer intake of the first pumper, using a large intake hose.
7. Open the hydrant completely. Both pumpers pump water to the fire, (refer to the procedure on “Pumping From a Hydrant”).

**NOTICE**

LOCAL TRAINING PROCEDURES MAY VARY FROM ABOVE.





### Pump To Road Shift Procedures

1. Verify that the operator's hand throttle or governor control has returned to idle speed.
2. Shift the truck transmission into the NEUTRAL position, and wait four seconds. Check to make sure the speedometer reads 0.
3. Moving pump shift control valve lever to the ROAD position. The in-cab and panel pump indicator lights should go out when the pump transmission starts to shift into the ROAD position.

### NOTICE

REFER TO THE FIRE DEPARTMENT PROCEDURES ON REMOVING WHEEL CHOCKS AS WELL AS LAY OUT AND CONNECTION OF SUCTION AND DISCHARGE HOSES.

### Standard Relief Valve Procedures

These procedures are for setting the operating point of the standard relief valve.

1. Increase the engine RPM to reach the desired pump operating pressure while reading the discharge pressure gauge.
2. Turn the hand wheel slowly counterclockwise until the relief valve opens, the pilot light comes on, and the master pressure gauge drops a couple of PSI (BAR).
3. Turn the hand wheel slowly clockwise until the master pressure gauge rises to the desired pressure and pilot light goes out. The relief valve will now operate at the set pressure.
4. When the pump is not in operation, turn the hand wheel clockwise so that the control is set slightly above the normal operating pressure. When the pump is put into operation again, reset the control valve to the desired operating pressure.

### TPM Relief Valve Procedures

These procedures cover the Hale TPM Relief Valve System. Be sure to select the correct procedure, according to relief valve.

#### TPM System (only)

1. Set the pressure indicator on the PMD control valve to a position slightly above the normal operating pressure (even before water starts to flow).
2. After normal operating pressure has been achieved (as indicated on the master pressure gauge and with the pump discharging water), slowly move the adjusting handwheel counterclockwise until the relief valve opens, the amber pilot light comes on, and the master pressure gauge reading drops a couple of PSI (BAR).
3. Turn the handwheel slowly clockwise until the master pressure gauge reading is at the correct operating pressure and the pilot light goes out. The relief valve will operate at the set pressure.

### NOTICE

THE INDICATOR ON THE PANEL IS ONLY A ROUGH INDICATION OF TPM SETTING. ALWAYS USE THE ABOVE PROCEDURE TO PROPERLY SET THE TPM RELIEF VALVE SYSTEM.

### TPM System with Engine Governor

1. Set the pressure indicator on the PMD control valve to a position slightly above the normal operating pressure (even before water starts to flow).
2. Power on the governor control.
3. Set the discharge pressure using the RPM mode of the pressure governor control.
4. Move the TPM handwheel counterclockwise until the relief valve opens and the amber pilot light comes on.

5. Turn the hand wheel slowly clockwise, until the amber light just goes out. Then turn the hand wheel one additional full turn clockwise for proper operation.

 **CAUTION**

THE TPM PRESSURE CONTROL VALVE MUST BE SET SLIGHTLY HIGHER THAN THE GOVERNOR CONTROL FOR PROPER OPERATION.

6. Put the governor control in the Pressure Governor mode; the system is now set.
7. Use the following procedures to change the set pressure while running:

#### Increasing Pressure

- a. Set the TPM to a pressure (by the indicator) slightly higher than the desired new pressure.
- b. Put the governor control in the RPM mode, and increase the speed to the new pressure.
- c. Move the TPM handwheel counterclockwise until the relief valve opens and the amber pilot light comes on.
- d. Turn the handwheel slowly clockwise, until the amber light just goes out. Then turn the handwheel one additional full turn clockwise for proper operation.

 **CAUTION**

THE TPM PRESSURE CONTROL VALVE MUST BE SET SLIGHTLY HIGHER THAN THE GOVERNOR CONTROL FOR PROPER OPERATION.

- e. Put the governor control in the Pressure Governor mode; the system is now set.

#### Decreasing Pressure

- a. Put the governor control in the RPM mode, and reduce the speed to the new pressure.
- b. Move the TPM handwheel counterclockwise until the relief valve opens and the amber pilot light comes on.
- c. Turn the handwheel slowly clockwise, until the amber light just goes out. Then turn the handwheel one additional full turn clockwise for proper operation.

 **CAUTION**

THE TPM PRESSURE CONTROL VALVE MUST BE SET SLIGHTLY HIGHER THAN THE GOVERNOR CONTROL FOR PROPER OPERATION.

- d. Put the governor control in the Pressure Governor mode; the system is now set.

#### Emergency Pump Shift Procedures

Before implementing manual override shift procedures, repeat recommended procedures. If the shift fails to take place, follow these procedures.

1. Bring the truck to a complete stop.
2. Apply the truck parking brake, and chock the wheels.
3. Shift the truck transmission to the NEUTRAL position.
4. For Pump or Road position, put the in-cab shift control in the Neutral position. (Neutral position is exactly in the middle of the road and pump position.
5. Shut down the engine.

 **WARNING**

DO NOT ATTEMPT EMERGENCY SHIFT PROCEDURES WHILE THE ENGINE IS RUNNING.

6. Employ manual override procedure at the shift cylinder on the pump gearbox as follows:

An eyebolt is provided in the shift shaft to accept a drift punch or screwdriver. By inserting this tool into the hole provided, it will enable you to pull or push the shaft manually. Pull the shift shaft Out for Pump Position (after in-cab control valve selection), or push shift shaft for Road Position (after in-cab control valve selection). If the shift stroke cannot be completed manually, turn the driveshaft slightly by hand to realign the internal gears and repeat the manual shift effort.

- a. Open discharge valves, remove suction tube caps, and discharge valve caps.
  - b. Open the pump body drain cocks or Hale multiple drain valve. If a multiple drain valve is used, all pump drain lines should be connected to this valve.
  - c. On two-stage pumps, move the transfer valve back and fourth to both the *volume* and *pressure* positions.
  - d. If installed, drain the gearbox cooler.
  - e. After the pump is completely drained, replace all caps and close all valves.
3. Fill out the pump run log, indicating total pumping time and total out-of-station time.
  4. Report all pump, vehicle equipment malfunctions, and irregularities to the proper authority.

### Post Operation Procedures

1. If you have been pumping seawater, dirty water, alkaline water, or using an around the pump proportioner, flush the pump with clean water.
2. After using the pump, drain the pump as follows (especially important in freezing weather):



### 3. PREVENTATIVE MAINTENANCE

#### A. Overview

Hale Midship Pumps require very little care and maintenance. However, the little required is extremely important. Preventive maintenance tasks require very little time to accomplish and consist mainly of testing for leaks, lubrication, and cleaning.

The procedures supplied in this section are for normal use and conditions. Extreme conditions may indicate a need for increased maintenance. The procedures in this section identify some extreme conditions and the additional measures needed to ensure lengthened pump life and continuing dependability.

The first part of this section includes some extreme condition maintenance guidelines. Sections with recommended activities to be accomplished on a weekly, a monthly, and an annual basis follow this. A separate maintenance checklist is provided to record completed maintenance actions.

#### B. Procedures

##### Post Operation Maintenance

1. If necessary, follow the procedures in the Extreme Maintenance Conditions paragraph.
2. On two-stage pumps, remove the suction tube strainers, and reach in to ensure that check valves are free to swing. Also, verify that no foreign matter is caught between the valve and the seat.
3. Inspect the suction hose rubber washers and washers in the suction tube caps. Remove foreign matter from under these washers. Replace worn, damaged, or dry washers.
4. Verify that all discharge valves, booster line valves, drain valves, and cocks are closed.
5. Tighten suction caps.

##### Extreme Conditions Maintenance Guidelines

Extreme conditions occur when the pump has been operated during freezing weather and as a result of pumping from a water source that contains material that will be harmful to the pump if not purged.

##### **During Freezing Weather**

In freezing weather, drain the pump as follows:

1. Open all discharge and suction valves, remove suction tube caps, and discharge valve caps.
2. Open pump body drain cocks and/or Hale multiple drain valve.
3. On two-stage pumps, move the transfer valve back and forth to both the *volume* and the *pressure* positions.
4. After the pump is completely drained, replace all caps and close all valves.

##### **After Pumping from Salt Water, Contaminated Water, or With Foam Solution**

After drafting from sea water, contaminated, sandy or dirty water, flush the pump and suction hoses by using water from a hydrant or other clean water source. After pumping foam through the pump, flush as above until all residues of foam have gone.

##### Weekly Maintenance

Weekly maintenance consists of testing the relief valve system or governor, the transfer valve on two-stage pumps, the priming system, and the pump shift warning indicator lights. If testing criteria is not met, refer to Section 4 for corrective maintenance.

### Relief Valve and TPM Test

When the relief valve is not in operation, maintain a setting above the normal operating pressure.

1. Set up to pump from the onboard water tank with the discharge valve back to the water tank open less than 1/2 way. See the procedures in Section 2 for assistance.
2. Bring the pump pressure up to 150 PSI (10 BAR) per normal operating procedures.
3. Turn the control valve handwheel counterclockwise until the relief valve opens and the pilot light is lit. Master pressure gauge should drop at least 5 to 10 PSI (0.5 to 1 BAR).
4. Turn the control valve handwheel clockwise then counterclockwise a few times to ensure that the handwheel turns freely. Master pressure gauge should increase and pilot light should go out. This action also ensures proper valve operation.
5. Reset the relief valve to its normal operational setting.

### Governor Test

If your apparatus is equipped with an electronic governor, follow the manufacturer's instructions for weekly preventive maintenance.

### Transfer Valve Test (Two Stage Pumps Only)

1. For manual transfer valves:
  - a. With the apparatus engine turned off, turn the handwheel between the volume and pressure positions a few times to verify that the valve operates freely.
  - b. Set the truck up for pumping per the procedure in Section 2, with the transfer valve in the volume position.
  - c. Leave the engine at idle speed, and move the transfer valve to the pressure position.
- d. Verify that the discharge pressure gauge readings have approximately doubled.
2. For power transfer valves:
  - a. With the apparatus engine turned off, use either a 3/8-inch socket on the indicator hex nut or a rod in the hole in the indicator hex nut to manually transfer the valve to verify that the valve operates freely.
  - b. Set the truck up for pumping per the procedures in Section 2, with the transfer valve in the volume position. Note the discharge gauge readings.
  - c. Leave the engine at idle speed, and move the transfer valve to the pressure position.
  - d. Verify that the master intake gauge readings have approximately doubled.

### Priming System Test

1. Tighten all pump caps, and close all pump valves.
2. Pull the primer control while you watch for a below-zero reading on the master intake gauge.
3. Verify that the master intake gauge readings hold for approximately 5 minutes after you release the primer control. A drop of 10 inches hg in this 5 minute period is anticipated per NFPA 1901.

### Pump Shift Warning Indicator Lights



BE SURE THAT THE PARKING BRAKE IS SET AND EVERYONE IS CLEAR OF THE TRUCK BEFORE SHIFTING TO THE PUMP POSITION. THE WHEELS MUST BE BLOCKED TO PREVENT ANY MOVEMENT OF THE TRUCK.

1. Follow the operating procedures in Section 2 to engage the pump.

2. Verify that the warning indicators in the cab and the pump control panel are on.
3. Switch to non-pumping operations, and verify the warning indicators are off.

### Valve Lubrication

1. Spray all moving parts of the suction, discharge, hose drain, and multi drain valves with a good grade of lithium base grease.
2. Lubricate all of the valve linkages.

### Monthly Maintenance

Monthly maintenance includes the Weekly Maintenance procedures plus lubrication, the packing gland adjustment, dry vacuum testing, and checking the drive line bolts. The Weekly Maintenance includes testing the relief valve system or governor, the transfer valve on two-stage pumps, the priming system, and pump shift warning indicator lights.

### Suction Check Valve Testing

On two-stage pumps remove the suction tube strainers, and reach inside the pump to ensure that the check valves are free to swing. Also, verify that no foreign matter is caught between the valve and the seat.

### Lubrication

1. On handwheel-type valves, including PM, PMD, and Transfer Valve Controls, if necessary, first remove old grease and paint, use a dry lubricating spray on gears.
2. Remove the gearbox oil fill plug (refer to the Hale Service Chart), and check the level of the oil in the gearbox. The level should be up to the plug hole. If necessary, add oil, using only a good grade of SAE EP 90 (oil should meet GL-5 requirements).
3. Lubricate suction threads with a light coat of grease.

### Packing Gland Adjustment

The packing gland is adjusted for a leakage of about 8 to 10 drops per minute at 150 PSI (10 BAR). This slight leakage will lubricate and cool the shaft and packing to prevent burning and scoring the shaft. First, check the leakage rate, and adjust the packing gland only if necessary. If the leakage rate cannot be adjusted within satisfactory limits, replace the packing per the instructions under Repacking in this section, page 3-6. Packing should be replaced every three years. The packing gland is adjusted as follows.

1. Connect the pump to a hydrant or some other source of water of about 150 pounds of pressure. If this is not possible, operate the pump at about 150 pounds from draft or from the booster tank discharging through the booster line, another small nozzle, or circulating back to the tank. Count the drops per minute.
2. Shut down engine to make adjustments.

### WARNING

**DO NOT RUN ENGINE WHILE MAKING PACKING ADJUSTMENTS.**

3. Loosen the packing nut lock. The lock is either a spring-loaded pin or a screw and locknut. The end of the lock fits into a slot in the gland.
4. To loosen or tighten the packing gland:
  - a. Insert a screwdriver or rod into one of the slots. Refer to the Hale Service Chart.
  - b. To loosen the nut, turn it in the direction of engine rotation.
  - c. To tighten the nut, turn it in the direction that is opposite to engine rotation.
5. Repeat step 1 and verify that leakage is correct. Tighten for less leakage, loosen for more leakage.





### Drive Line and Flange Bolts

Check all drive line and flange bolts to ensure:

1. No bolts are missing.
2. All bolts are tight.
3. Bolts used are “Grade 8” strength.

### Pump Mounting Bolts

1. No bolts are missing.
2. All bolts are tight.

### Priming System Test (Dry Vacuum Test)

## NOTICE

IN THE FOLLOWING PRIMING SYSTEM TEST, IF LEAKS CANNOT BE DETECTED BY FOLLOWING THE PROCEDURE BELOW, IT IS ADVISABLE TO TEST THE PUMP HYDROSTATICALLY. TO DO THIS CONNECT THE PUMP TO A SOURCE OF WATER, AND LOOK FOR LEAKS.

1. Close all valves and drains. Cap all suction openings and the outlet of the suction side relief valve (if so equipped).
2. Connect a test vacuum gauge or manometer to the intake test gauge connection on the pump panel.
3. Engage the priming pump until the gauge indicates 22 inches or more mercury vacuum.
4. Watch the gauge. If the vacuum falls more than 10 inches in 5 minutes, it is a certain indication of at least one air leak. Vacuum leaks may often be detected by ear if the apparatus engine is turned off. Correct leaks immediately to return the pump to a serviceable condition.
5. Test the suction hose as follows:

- a. Attach the suction hose to the pump.
- b. Place the suction tube cap on the end of the hose in place of a strainer.
- c. Close all valves and drains. Cap all suction openings and the outlet of the suction side relief valve (if so equipped).
- d. Connect a test vacuum gauge or manometer to the intake test gauge connection on the pump panel.
- e. Engage the priming pump until the gauge indicates at least 22 inches mercury.
- f. Watch the gauge. If the vacuum falls more than 10 inches in 5 minutes, it is a certain indication of at least one air leak. Vacuum leaks may often be detected by ear if the apparatus engine is turned off. Correct leaks immediately to return the pump to a serviceable condition.

### Relief Valve System Check

1. Place apparatus out of service in accordance with departmental procedures.
2. Test relief valve system in accordance with Weekly Maintenance Check. If the relief valve is not working, clean the strainers as follows:
  - a. Open pump compartment panel and locate the relief valve system strainer(s). (On all relief valve systems the strainer is located in one of the pump pressure taps. On TPM an additional strainer is located in one of the pump vacuum taps).
  - b. Disconnect tubing then remove strainer from respective tap.
  - c. Clean any debris from strainer and check strainer for damage.
  - d. Using a suitable thread sealant (Loctite PST or equal) reinstall strainer.
  - e. Reconnect tubing.





- f. Test apparatus and check for leaks around strainer fittings
3. Place apparatus back in service.

### Indicator Light Test

1. Operate component with indicator lights and observe the respective indicator lights. If the indicator light fails to light replace the bulb and test again.

### Annual Maintenance

Annual maintenance consists of post-operation, weekly, and monthly maintenance. Maintenance for extreme conditions may also apply. In addition, the annual maintenance includes the following tasks.

- Gauge calibration check.
- Autolube® assembly oil level check: fill or replace with SAE EP 90 or 80W90 weight oil.
- Lubricating the power transfer cylinder, power shift cylinder, and shift control valve with air cylinder oil.
- Replacing the pump gearbox oil: use SAE EP 90 or 80W90 weight oil (GL-5 equivalent).
- Checking individual drain lines from the pump to the multi-drain to ensure proper drainage and protection from freezing.
- Running the yearly pump test to check performance levels. (See NFPA 1911 pamphlet for more details).
- Repacking the pump at three-year intervals.

### Performance Testing Overview

The yearly standard performance test consists of checking the pumper, according to rating, at three capacities and comparing the results to when the pump was new. This provides some measure of performance deterioration, if any. For performance

testing criteria refer to the latest version of NFPA 1911 pamphlet. Pumpers are rated at capacities of 500, 750, 1000, 1250, 1500, 1750, 2000, or 2250 GPM (1892, 2839, 3785, 4731, 5678, 6624, 7570, or 8516 LPM). See Table 3-1.

### Performance Testing Equipment and Materials

To accurately test pumper performance, you will require a pitot gauge, a pump master pressure gauge, and a master vacuum gauge or manometer. ALL gauges must be carefully tested for accuracy. Gauge testing is appropriately accomplished with a dead weight gauge tester, which is usually available at the local water works.

Pumpers should be tested from draft at not over a 10-foot lift with 20 feet of suction hose. Pumpers rated at 1500 GPM and over often require two separate 20-foot lengths of suction hose and a lower lift height.

Use smooth bore test nozzles of accurate size with the pitot gauge. The volume pumped is then determined by reference to discharge tables for smooth nozzles. Refer to Table 3-2 for Nozzle Flow Rates. Preferably, nozzles will be used on a Siamese deluge gun for greatest accuracy. A stream straightener, just upstream of the nozzle is advisable.

The amount of discharge hoses required for the service tests is dependent on the flow requirements and capacity test point. The most common discharge hose used is 2-1/2 inches in diameter 100 feet long. The number of hoses and length should be sufficient to reduce nozzle pressure to between 30 and 85 PSIG (2 and 6 BAR). In general refer to the hose friction loss chart in Table 3-3 for a determination as to the friction loss in 100 feet of hose. Refer to Table 3-4 for suggested nozzle sizes for service testing of common size pumps.



**TABLE 3-1.**

CAPACITY	PRESSURE PSI (BAR)	PUMP RATING GPM (LPM)							
		500	750	1000	1250	1500	1750	2000	2250
FULL	150 (10)	500 (1892)	750 (2839)	1000 (3785)	1250 (4731)	1500 (5678)	1750 (6624)	2000 (7570)	2250 (8516)
FULL	165 (11)	500 (1892)	750 (2839)	1000 (3785)	1250 (4731)	1500 (5678)	1750 (6624)	2000 (7570)	2250 (8516)
70%	200 (13)	350 (1325)	525 (1987)	700 (2650)	875 (3312)	1050 (3974)	1225 (4637)	1400 (5299)	1575 (5961)
50%	250 (17)	250 (946)	375 (1419)	500 (1893)	625 (2366)	750 (2839)	875 (3312)	1000 (3785)	1125 (4258)

**TABLE 3-2.**

NOZZLE PRESS	GPM AT VARIOUS NOZZLE SIZES							
	½"	5/8"	¾"	7/8"	1"	1 1/8"	1 ¼"	1 3/8"
30	41	64	92	125	163	206	254	308
35	44	69	99	135	176	222	275	332
40	47	73	106	144	188	238	294	355
45	50	78	112	153	199	252	311	377
50	53	82	118	161	210	266	328	397
55	55	86	124	169	220	279	344	417
60	58	90	130	176	230	291	360	435
62	58	91	132	179	234	296	366	442
64	59	93	134	182	238	301	371	449
66	60	94	136	185	241	305	377	456
68	61	96	138	188	245	310	383	463
70	62	97	140	190	248	315	388	470
72	63	99	142	193	252	319	394	477
74	64	100	144	196	255	323	399	483
76	65	101	146	198	259	328	405	490



**TABLE 3-2. (Continued)**

NOZZLE PRESS	GPM AT VARIOUS NOZZLE SIZES							
	½"	5/8"	¾"	7/8"	1"	1 1/8"	1 ¼"	1 3/8"
78	66	103	148	201	262	332	410	496
80	66	104	150	203	266	36	415	502
85	68	107	154	210	274	347	428	518
90	70	110	159	216	282	357	440	533
95	72	113	163	222	289	366	452	547
100	74	116	167	228	297	376	464	562
105	76	119	171	233	304	385	476	575
110	78	122	175	239	311	394	487	589
115	80	125	179	244	319	403	498	602
120	81	127	183	249	325	412	509	615

NOZZLE PRESS	GPM AT VARIOUS NOZZLE SIZES							
	1 ½"	1 5/8"	1 ¾"	1 7/8"	2"	2 1/4"	2 ½"	3"
30	366	430	498	572	651	824	1017	1464
35	395	464	538	618	703	890	1098	1581
40	423	496	575	660	751	951	1174	1691
45	448	525	610	700	797	1009	1245	1793
50	473	555	643	738	840	1063	1313	1890
55	496	582	675	774	881	1115	1377	1982
60	518	608	705	809	920	1165	1438	2071
62	526	618	716	822	935	1184	1462	2105
64	535	628	728	835	950	1203	1485	2138
66	543	637	739	848	965	1222	1508	2172
68	551	647	750	861	980	1240	1531	2204
70	559	656	761	874	994	1258	1553	2236

**TABLE 3-2. (Continued)**

NOZZLE PRESS	GPM AT VARIOUS NOZZLE SIZES							
	1 ½"	1 5/8"	1 ¾"	1 7/8"	2"	2 1/4"	2 ½"	3"
72	567	666	772	886	1008	1276	1575	2268
74	575	675	783	898	1022	1293	1597	2299
76	583	684	793	910	1036	1311	1618	2330
78	590	693	803	922	1049	1328	1639	2361
80	598	702	814	934	1063	1345	1660	2391
85	616	723	839	963	1095	1386	1711	2465
90	634	744	863	991	1127	1427	1761	2536
95	651	765	887	1018	1158	1466	1809	2605
100	668	784	910	1044	1188	1504	1856	2673
105	685	804	932	1070	1217	1541	1902	2739
110	701	823	954	1095	1246	1577	1947	2803
115	717	841	976	1120	1274	1613	1991	2867
120	732	859	997	1144	1301	1647	2034	2928



**TABLE 3-3.**

HOSE FRICTION LOSS (PSI PER 100 FEET)													
GPM Flowing	3/4" Booster	1" Booster	1 1/2" Hose	GPM Flowing	1 3/4" Hose with 1 1/2" Couplings	2" Hose with 1 1/2" couplings	2 1/2" Hose	3" Hose with 2 1/2" Couplings	3" Hose	GPM Flowing	3 1/2" Hose	4" Hose	5" Hose
10	13.5	3.5		95	14	8				500	9.5	3	
20	44	6		125	24	13				750	20	11	5
30	99	14		150	35	18				1000	34	20	8
40	176	24	4	175	47	25	6			1250	53	31	13
50		38	7	200	62	32	8			1500	74	45	18
60		54	9	225			10			1750		61	25
70			12	250			13	5	4	2000			32
80			15	275			15						
95			22	300			18						
125			38	325			22	8					
150			54	350			25		8				
				500				20	17				
				750				45	38				
				1000				80	68				

NOTE: Add 5 PSI for each story of building and each wye or siamese. Friction Loss Calculations courtesy of IFSTA.

**TABLE 3-4.**

PUMP RATING	SUGGESTED NOZZLE SIZE (INCHES)		
	FULL CAPACITY	70% CAPACITY	50% CAPACITY
750	1-3/4	1-3/8	1-1/4
1000	2	1-5/8	1-3/8
1250	(2) 1-1/2 or 2-1/4	1-7/8	1-1/2
1500	(2) 1-3/4 or 2-1/4	2	1-3/4
1750	(2) 2	(2) 1-1/2 or 2-1/4	1-7/8
2000	(2) 2	(2) 1-3/4 or 2-1/4	2
2250	(2) 2-1/4	(2) 1-3/4 or 2-1/4	2

The following general guidelines should be used when testing the apparatus.

For 750 GPM (2839 LPM) test, two 2-1/2-inch lines should be laid from the pumper to the nozzle. For 1000 GPM (3785 LPM) test, three lines are required, and for the 1250 (4731 LPM) and 1500 GPM (5677 LPM) tests, four or more lines are required between the pumper and the nozzle. For 1750 (6624 LPM) and 2000 GPM (7570 LPM) tests four or more hose lines and two nozzles are required. For testing a 2250 GPM (8516 LPM) pumper up to six hose lines into two separate nozzles should be used.

Because deluge guns are not always available, other hose layouts may be used, such as one, 2 1/2-inch line to a 1-3/8-inch nozzle for 500 GPM (1892 LPM). Generally, the nozzle used on one, 2 1/2-inch line should not be larger than 1 1/2 inches for accuracy in measuring GPM (LPM). Another alternative when a deluge gun is not available consists of a 1 1/4 inch nozzle on one and a 1 1/2 inch nozzle on the other to pass 1000 GPM (3785 LPM). The sum of the flow from both nozzles is the GPM (LPM) delivered by the pump. For good pilot gauge accuracy, the nozzle pressures should be between 30 and 85 PSIG (2.1 and 5.8 BAR).

Because NFPA standards specify both GPM (LPM) and pressure, it is usually necessary to restrict the flow somewhat to build up the pump pressure. In normal pumping, this restriction would be caused by the friction loss in the lines. However, depending on line loss alone would require a large amount of hose for some tests. For example, testing a 500 GPM (1892 LPM) Class A pumper at 250 GPM (946 LPM) and 250 PSI (17.2

BAR) requires 72-PSI (5 BAR) nozzle pressure on a one-inch tip. To reduce the pressure from 250 PSI (17.2 BAR) at the pump to 72 PSI (5 BAR) at the nozzle would require approximately 1100 feet of 2 1/2-inch hose. Therefore, it is common practice to use 50 to 100 feet of hose and gate the discharge valves as required.

### Performance Testing

Note that the NFPA standards require a 10 percent reserve in pressure at the capacity run when the apparatus is delivered.

1. Check the relief valve according to the Relief Valve Testing procedure under Weekly Maintenance.
2. Perform steps 1 and 2 of the Post Operation Maintenance procedures in this section.
3. Run the standard pump test in accordance with NFPA standards to check pump performance.
4. Run the engine for 20 to 30 minutes to stabilize the engine temperature. Then run the pump for 20 minutes at capacity, 10 minutes at 70 percent capacity, and 10 minutes at 50 percent capacity.
5. If the apparatus does not reach performance levels, refer to the Hale diagnostic/service chart (Section 4).
6. Compare the results of this test to those from when the apparatus was delivered. It maybe that the apparatus did not show the 10 percent reserve at delivery. If the apparatus

performance has dropped appreciably compared to its original performance, it needs to be serviced. (Apparatus test results should be on file with the delivery documents. If not, they may be obtained from the apparatus manufacturer or from the original certifying authority).

### Repacking

Refer to figure 1-9 for a cross-section showing the packing arrangement and number of packing rings. The three rings adjacent to the packing gland can be replaced without disassembling the pump. The ring in front of the lantern does not need to be replaced. Repack the pump as follows.

#### **WARNING**

DO NOT RUN ENGINE WHILE MAKING PACKING ADJUSTMENT.

1. Loosen the packing nut lock.
2. Loosen the packing gland. If necessary, soak the threads with penetrating oil and work the nut back and fourth to loosen it. Loosen the adjusting gland just enough to remove the split glands. If the front part of the gland is of the split type, remove the two halves.
3. Remove the old packing rings with a packing hook. The hook can be made from a bent piece of stiff wire or small pointed rod. Another type of packing hook consists of a corkscrew on the end of a flexible shaft. Be sure to remove all shreds of old packing, and clean out the packing housing as much as possible.
4. Remove all old packing, dirt, and foreign matter from the bearing housing under the gland.
5. Repack using the Hale packing kit recommended for your particular pump. For most pumps, the packing is 7/16 inch square cut to the proper length. Wrap one length of packing around the shaft to form a ring, and push the ring into the packing housing. Install the second ring the same way, but stagger the

joint one-third of the way around from the first joint. Put a foil separator between each packing ring. The foil separator must be cut to fit the shaft. Install the other rings, again staggering the joints.

6. Replace the gland and adjust it according to the Packing Gland Adjustment procedure in this section.
7. Operate the pump normally for about 15 minutes at 130 PSI (9 BAR), and check the packing gland. If necessary, adjust the packing nut again according to the Packing Gland Adjustment procedure in this section.

### Annual MIV and 40BD Relief Valve Test and Adjustment

#### **WARNING**

NEVER SET RELIEF VALVE ABOVE HOSE MANUFACTURERS RATED WORKING PRESSURE. ALWAYS USE THE LOWEST POSSIBLE RELIEF VALVE SETTING TO ENHANCE OPERATOR AND EQUIPMENT SAFETY.

#### **WARNING**

PER NFPA 1962 REQUIREMENTS, LARGE DIAMETER HOSE MARKED "SUPPLY HOSE" 3-1/2 TO 5 INCHES (89 TO 127 MM) DIAMETER SHALL NOT BE USED AT OPERATING PRESSURES EXCEEDING 185 PSI (13 BAR).

#### **WARNING**

PER NFPA 1962 REQUIREMENTS, LARGE DIAMETER HOSE MARKED "SUPPLY HOSE" 6 INCHES (152 MM) DIAMETER SHALL NOT BE USED AT OPERATING PRESSURES EXCEEDING 135 PSI (9 BAR).

The 40BD MIV relief valve is factory set to open at 125 PSI (9 BAR). The relief valve can be adjusted to open from 75 to 250 PSI (5 to 17



BAR). Test and set relief valve as necessary using the following procedures and figure 3-1.

1. Open operator panel and gain access to the relief valve adjustment cap screw.
2. Make sure the valve is closed and install a pressure test cap on the suction tube or discharge fitting.

8. Lock the pressure setting by turning the adjustment locking screw until tight. Lock screw in place with Loctite #290 or equivalent.
9. Turn off water source and relieve pressure through the air bleeder allowing relief valve to reset.
10. Reenergize water source and return the

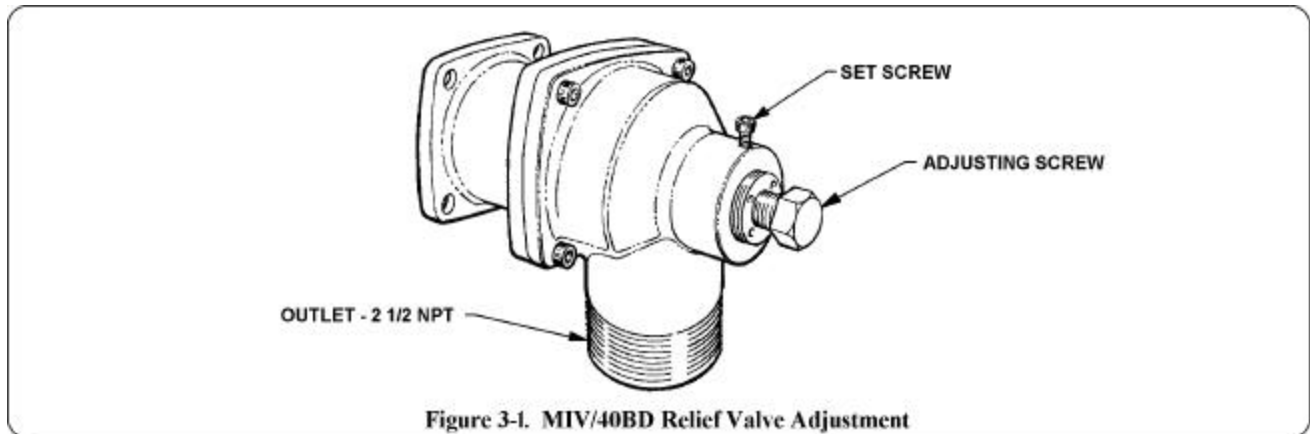

3. Connect a pressurized water source or hydrostatic test pump and water supply to the pressure test cap fitting.
4. Open water supply valve and air bleed valve. Fill suction tube or discharge connection until water flows from air bleed. Close air bleed.
5. Pressurize to desired set pressure in accordance with the above warnings. Observe whether relief valve opens or remains closed at the desired pressured.
6. Using a 3/16 inch allen wrench loosen, BUT DO NOT REMOVE, the set screw that locks the pressure adjustment cap screw.
7. Using 7/8 inch open end wrench, turn pressure adjustment cap screw to set relief valve pressure (clockwise to increase opening pressure or counterclockwise to decrease opening pressure). Turn cap screw until relief valve just opens or closes.

Once relief valve opens or closes turn pressure adjustment cap screw 1/4 turn in the clockwise (increase pressure) direction.

pressure to the relief valve set point to verify valve-opening point. Repeat adjustment procedures as necessary to verify relief valve operation.

11. Open drain valve and drain water from suction tube or discharge connection.
12. Disconnect water supply and remove test cap from suction tube or discharge connection.
13. Close operator panel and return apparatus to normal ready condition.

### Worn Clearance Rings and Impeller Hubs

Because clearance ring replacement requires pump disassembly, it is advisable to thoroughly check other possible causes (see Table 4-1) of low performance before assuming that clearance ring wear is at fault.

Clearance (that is, sealing) rings limit the internal bypass of water from the discharge side of the pump back to the suction. The radial clearance between the impeller hub and the clearance rings is only a few thousandths of an inch when new, effectively preventing a large bypass.



In clear water, the clearance rings continue to effectively seal for hundreds of hours of pumping. In dirty or sandy water, the impeller hub and clearance rings will wear faster than in clear water. The more the wear, the greater the bypass and the lower pump performance. Also, the greater the pressure at which each stage is operated, the larger will be the bypass and the more the performance will be lowered.

When new, the radial clearance between the impeller hubs and the clearance ring is from 0.005 to 0.007 inch per side. Any increase will allow more bypass and result in lower performance. But when the pump is adequately powered, it should not be necessary to replace clearance rings and impellers until the average radial clearance reaches 0.015 to 0.020 inch or more per side, as measured by a feeler gauge.

Often, replacement of the clearance rings is all that is necessary. This will largely reduce the bypass and restore the pump to near original performance. A complete restoration requires that oversize clearance rings be installed and the impeller turned or the impeller may also be replaced.

**Anode Check**

The zinc anodes should be inspected every 12 months. Replace when over 75% of the zinc has been consumed (Refer to figure 6-15 for original dimensions). Performance of the anode life will vary with water quality and pH. Anodes conform to MIL Spec A180001.

**TRV Test**

The TRV should be tested every 12 months. The following procedure should be used to test the TRV. Before testing, make sure a clear view is available to the TRV discharge.



DO NOT RUN PUMP FOR LONGER THAN IS SHOWN IN THE TABLE, AS OVERHEATING COULD OCCUR AND SERIOUS DAMAGE TO PUMP WILL RESULT.

1. Close all discharge valves including pump and engine coolers so there is no flow through the pump.
2. Use care that engine does not overheat, set the pump discharge pressure to one of the pressures listed.

PRESSURE	Time in Minutes	
	TRV120 TRVM120	TRV170 TRVM170
200 PSIG (13.8 Bar)	10	20
400 PSIG (27.6 Bar)	4	8
600 PSIG (41.4 Bar)	2	4

3. The thermal relief valve should discharge water through the 1/8 NPT or metric discharge line approximately within the time specified.
4. The table is for midship type pumps. The thermal relief valve will open faster on smaller pumps, dependent on how close it is to the impeller.
5. The table is based on 70°F (21°C) water and 70°F (21°C) air temperature. The thermal relief valve will open faster in hotter conditions and slower in cooler conditions.
6. Units equipped with TRV-L kit will flow up to 1-2 GPM (3-7 LPM) of water before lamp turns on.

If unit fails to open in time allotted, remove TRV in accordance with Procedures in Section 5.

Place TRV-120 on work area with inlet facing up. Pour water of 120°-130°F (66° to 72°C) into opening of TRV. Element should open allowing water to flow out, if valve does not open replace valve. For TRV-170, use water at 170° to 180° (77° to 82° C).

Refer to figure 32 for a service chart including recommended service points and intervals.

# SERVICE CHART HALE TYPE QPAK, QFLO, QMAX, & QTWO PUMPS

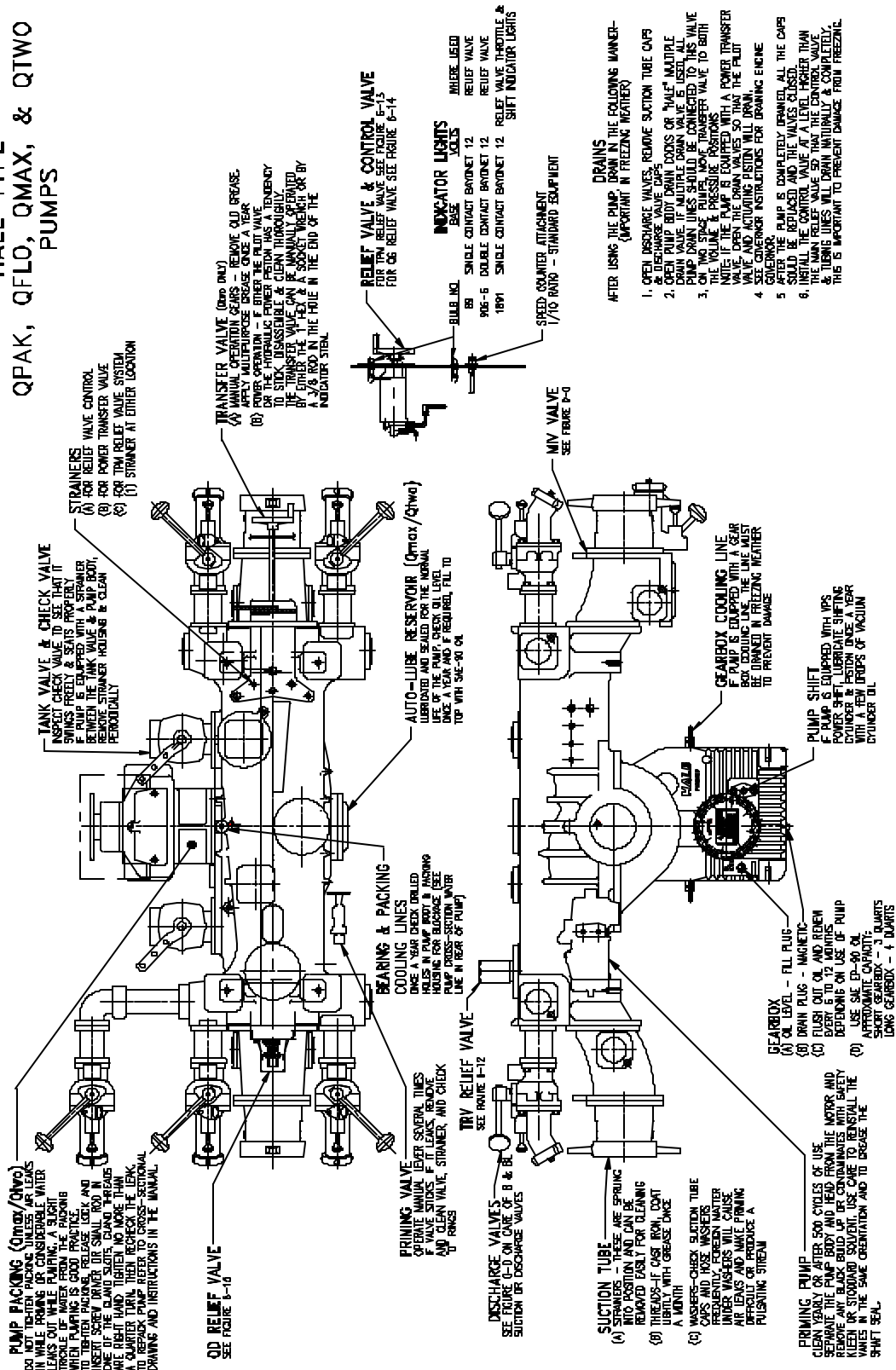

Figure 3-2. Qpak, Qflo, Qmax, & Qtwo Pumps Service Chart



## Midship Pump Maintenance Check List

Truck Manufacturer \_\_\_\_\_

Pump Model & Serial Number \_\_\_\_\_

Year \_\_\_\_\_ Unit# \_\_\_\_\_

# RECOMMENDED WEEKLY PROCEDURES

- Test relief valve system or governor at 150, 200, 250 PSIG.
- Test transfer valve (if applicable).
- Test the priming system (check lubrication level in priming tank were installed).
- Lubricate all valves, discharge, suction, hose, drain, and multi-drain.
- Check pump shift warning indicator lights.

RECOMMENDED MONTHLY PROCEDURES	JAN	FEB	MAR	APR	MAY	JUN	JUL	AUG	SEP	OCT	NOV	DEC
Complete weekly checks												
Lubricate threads on PM relief valve panel control and check light												
Lubricate remote valve controls												
Check controlled packing leakage and adjust if necessary (8 to 10 drops per minute)												
Perform dry vacuum test*												
Check drive flange bolts to ensure tightness												
Lubricate suction tube threads												
Clean strainer												
Inspect gaskets												
Check oil level in pump gearbox; add oil if necessary												
If necessary, replace oil with SAE EP 90 oil												

\*Per NFPA-1911, 22 inches Hg minimum vacuum: loss not to exceed 10 inches Hg vacuum in 5 minutes.

# RECOMMENDED ANNUAL PROCEDURES

- Complete all previous checks on all questions.
- Check gauge calibration.
- Check oil level in AutoLube® assembly (SAE-EP 90 or 80W-90); see operation and maintenance manual for details.
- Lubricate power transfer cylinder, power shift cylinder, and shift control valve with vacuum cylinder oil, if applicable.
- Change pump gearbox oil and refill (SAE-EP 90 oil or 80W-90).
- Check individual drain lines from pump to multi-drain to ensure proper drainage and protection from freezing.
- Lubricate transfer valve mechanism on two stage pumps. Dry moly spray is preferred.
- Run yearly standard pump test (per NFPA-1911) to check pump performance levels – chart provided below.
- Repacking of pump is recommended every two or three years.

**NOTE:** The above general recommendations are provided for normal use and conditions. Extreme conditions or variables may indicate a need for increased maintenance. Good preventative maintenance lengthens pump life and ensures greater dependability. Consult service or diagnostic chart in operator's manual for detailed information.

### ANNUAL PUMP TEST RESULTS

	Capacity @ 150 PSI	70% Capacity @ 200 PSI	50% Capacity @ 250 PSI
Hose Layout			
Nozzle Size			
Nozzle Pressure			
Gallons Per Minute			
Pump Pressure Current Engine Speed			
Engine Speed from Original Test Documents			
Lift and Suction Hose Size and Number			



## 4. TROUBLESHOOTING

Table 4-1 lists the symptoms of some common problems and possible corrective measures. Before calling Hale or a Hale authorized parts service center for assistance, eliminate problem causes using Table 4-1. If you cannot correct a problem, please have the following information ready prior to calling the Hale Customer Service Technician Department for assistance. Customer Service Number: 610-825-6300.

- ❑ Pump Model and Serial Number
- ❑ Pump Configuration Information
- ❑ Observed Symptoms and Under What Conditions The Symptoms Occur

**TABLE 4-1. HALE MIDSHIP PUMP TROUBLE ANALYSIS**

CONDITION	POSSIBLE CAUSE	SUGGESTED CORRECTION
<b>PUMP WILL NOT ENGAGE</b>  Standard transmission with Manual Pump Shift	Clutch not fully disengaged or malfunction in shift linkage	Check clutch disengagement. Drive shaft must come to a complete stop before attempting pump shift
Automatic Transmission with Manual Pump Shift	Automatic transmission not in neutral position	Repeat recommended shift procedures with transmission in neutral position
Standard Transmission with Power Shift System	Insufficient air supply in shift system  Clutch not fully engaged or malfunction in shift linkage.	Repeat recommended shift procedures.  Check system for loss of air supply.  Check clutch disengagement. Drive shaft must come to a complete stop before attempting pump shift  Turn the engine off and employ shift override procedures as follows: 1. Hole is provided in shift shaft to accomplish emergency shifting. 2. Complete shift of control in cab to neutral and proceed to complete shift of lower control manually.
Automatic Transmission With Power Shift System		Repeat recommended shift procedures with transmission in neutral position.  Release braking system momentarily. Then reset and repeat recommended shifting procedures.  Release braking system momentarily. Then reset and repeat recommended shifting procedures.



CONDITION	POSSIBLE CAUSE	SUGGESTED CORRECTION
Automatic Transmission With Power Shift System (continued)	Insufficient air in shift system  Air leaks in shift system	Repeat recommended shift procedures.  Check system for loss of air. Check of leak in system. Employ manual override procedures if necessary. See Standard Transmission with Power Shift System.  Attempt to locate and repair leak(s). Leakage, if external, may be detected audibly. Leakage could be internal and not as easily detected.

# NOTICE

**DO NOT LEAVE THE CAB AFTER PUMP SHIFTING UNLESS THE SHIFT INDICATOR LIGHT IS ON, OR A SPEEDOMETER READING IS NOTED.**

CONDITION	POSSIBLE CAUSE	SUGGESTED CORRECTION
<p><b>PUMP LOSES PRIME OR IT WILL NOT PRIME</b></p> <p>NOTE: Weekly priming pump operation is recommended to provide good operation.</p>	<p>Electric Priming System</p> <p>Defective Priming System</p> <p>Suction lifts too high</p> <p>Blocked suction strainer</p> <p>Suction connections</p> <p>Primer not operated long enough.</p>	<p>No recommended engine speed is required to operate the electric primer, however, 1,000 engine RPM will maintain truck electrical system while providing enough speed for initial pumping operation</p> <p>Check priming system by performing “Dry Vacuum Test” per NFPA standards. If pump is tight, but primer pulls less than 22 inches of vacuum, it could indicate excessive wear in the primer.</p> <p>Do not attempt lifts exceeding 22 feet except at low elevation.</p> <p>Remove obstruction from suction hose strainer.</p> <p>Clean and tighten all suction connections. Check suction hose and hose gaskets for possible defects.</p> <p>Proper priming procedures should be followed. Do not release the primer control before assuring a complete prime. Open the discharge valve slowly during completion of prime to ensure same.</p> <p><b>NOTICE:</b> Do not run the primer over 45 seconds. If prime is not achieved in 45 seconds, stop and look for causes (for example, air leaks or blocked suction).</p>



CONDITION	POSSIBLE CAUSE	SUGGESTED CORRECTION
<b>PUMP LOSES PRIME OR IT WILL NOT PRIME (CONTINUED)</b>	Air Trap in Suction Line  Pump Pressure too low when nozzle is opened  Air Leaks	Avoid placing any part of the suction hose higher than the suction intake. Suction hose should be laid with continuous decline to water supply. If trap in hose is unavoidable, repeated priming may be necessary to eliminate air pocket in suction hose.  Prime the pump again and maintain higher pump pressure while opening discharge valve slowly.  Attempt to locate and correct air leaks using the following procedure.  <ol style="list-style-type: none"><li>1. Perform dry vacuum test on pump per NFPA standards with 22 inches minimum vacuum required with loss not to exceed 10 inches of vacuum in 5 minutes.</li><li>2. If a minimum of 22 inches of vacuum cannot be achieved, the priming device or system may be defective, or the leak is too big for the primer to overcome (such as an open valve). The loss of vacuum indicates leakage and could prevent priming or cause loss of prime.</li><li>3. Attempt above dry prime and shut off engine. Audible detection of a leak is often possible.</li><li>4. Connect the suction hose from the hydrant or the discharge of another pumper to pressurize the pump with water, and look for visible leakage and correct. A pressure of 100 PSI (6.9 BAR) should be sufficient. Do not exceed pressure limitations of pump, pump accessories, or piping connections.</li><li>5. Check pump packing during attempt to locate leakage. If leakage is in excess of recommendations, adjust accordingly following instructions in Section 3.</li><li>6. The suction side relief valve can leak. Plug the valve outlet connection and retest.</li></ol>





CONDITION	POSSIBLE CAUSE	SUGGESTED CORRECTION
<p><b>INSUFFICIENT PUMP CAPACITY</b></p>	<p>Insufficient engine power</p> <p>Transfer Valve not in proper “Volume” position</p> <p>Relief Valve improperly set</p> <p>Engine Governor set incorrectly</p> <p>Truck transmission in wrong gear or clutch is slipping</p> <p>Air Leaks</p>	<p>Engine power check or tune up may be required for peak engine and pump performance.</p> <p><b>TWO STAGE PUMPS ONLY.</b> Place transfer valve in “Volume” position (parallel) when pumping more than 1/2 rated capacity. For pressure above 200 PSI (13.8 BAR), pump should be placed in “Pressure” (series) position.</p> <p>If relief valve control is set for too low a pressure, it will allow relief valve to open and bypass water. Reset Relief Valve control per the procedures in Section 3. Other bypass lines (such as foam system or inline valves) may reduce pump capacity or pressure.</p> <p>Engine governor, if set too low a pressure when on automatic, will decelerate engine speed before desired pressure is achieved. Reset the governor per manufacturer’s procedures.</p> <p>Recheck the pumping procedure for the recommended transmission or gear range; see Section 3 for assistance.</p> <p>Use mechanical speed counter on the pump panel to check speed against possible clutch or transmission slipping or inaccurate tachometer. (Check the truck manual for the proper speed counter ratio).</p> <p>See air leaks under <b>“PUMP LOSES PRIME OR WILL NOT PRIME”</b>.</p>
<p><b>INSUFFICIENT PRESSURE</b></p>	<p>Check similar causes for insufficient capacity</p> <p>Transfer Valve not in “Pressure” position</p>	<p>Recheck pumping procedure for recommended transmission gear or range. Use mechanical speed counter on pump panel to check actual speed against possible clutch or transmission slippage or inaccurate tachometer. (Check the truck manual for proper speed counter ratio).</p> <p><b>TWO STAGE PUMPS ONLY.</b> For desired pump pressure above 200 PSI (13.8 BAR), transfer valve should be in “Pressure” position.</p>



CONDITION	POSSIBLE CAUSE	SUGGESTED CORRECTION
<b>LEAK AT PUMP PACKING</b>	Packing out of adjustment or worn.	Adjust the packing per the procedure in Section 3 of this manual (8 to 10 drops per minute leakage at 150 PSI (10 BAR) preferred).  Replace pump packing per Section 3 of this manual. Packing replacement is recommended every 2 or 3 years depending on usage.
<b>REMOTE CONTROL DIFFICULT TO OPERATE</b>	Lack of lubrication	Lubricate the remote control linkages and collar with oil.
<b>ENGINE SPEEDS TOO HIGH FOR REQUIRED CAPACITY OR PRESSURE</b>	<p>Truck transmission in wrong range or gear</p> <p>Lift too high, suction hose too small</p> <p>Defective suction hose</p> <p>Blockage of suction hose entry</p> <p>Worn pump impeller(s) and clearance rings</p> <p>Impeller blockage</p>	<p>Check recommended procedures for correct transmission selection; see Section 3 and truck manual.</p> <p>Higher than normal lift (10 feet) will cause higher engine speeds, high vacuum and rough operation. Use larger suction hose.</p> <p>Inner line of suction hose may collapse when drafting and is usually undetectable. Try a different suction hose on same pump; test for comparison against original hose.</p> <p>Clean suction hose strainer of obstruction and follow recommended practices for laying suction hose. Keep off the bottom of the water supply but at least 2 feet below the surface of the water.</p> <p>Installation of new parts required.</p> <p>Blockage in the impeller can prevent loss of both capacity and pressure. Back flushing of pumps from discharge to suction may free blockage. Removal of one half of the pump body may be required (this is considered a major repair).</p>
<b>RELIEF VALVE DOES NOT RELIEVE PRESSURE WHEN VALVES ARE CLOSED</b>	<p>Incorrect setting of Control (Pilot) Valve</p> <p>Relief Valve inoperative</p>	<p>Check and repeat proper procedures for setting relief valve system. (see Section 3)</p> <p>Possibly in need of lubrication. Remove relief valve from pump; dismantle; clean and lubricate. Weekly use of the Relief Valve is recommended.</p>



CONDITION	POSSIBLE CAUSE	SUGGESTED CORRECTION
<b>RELIEF VALVE DOES NOT RECOVER AND RETURN TO ORIGINAL PRESSURE SETTING AFTER OPENING VALVES</b>	Dirt in system causing sticky or slow reaction	Relief valve dirty or sticky. Follow instructions for disassembling, cleaning, and lubricating.  Blocked relief valve. Clean the valve with a small wire or straightened paper clip.
<b>RELIEF VALVE OPENS WHEN CONTROL VALVE IS LOCKED OUT</b>	Drain hole in housing, piston, or sensing valve blocked	Clean the hole with a small wire or straightened paper clip.  Dismantle and clean the sensing valve.
<b>UNABLE TO OBTAIN PROPER SETTING ON RELIEF VALVE</b>	Wrong procedure  Blocked strainer  Foreign matter in the Control Valve  Hunting condition	Check instruction for setting the relief valve and reset.  Check and clean the strainer in the supply line from the pump discharge to the control valve. Check the truck manual for the exact location. Check and clean tubing lines related to the relief valve and control valve.  Remove the control valve and clean.  Insufficient water supply coming from the pump to the control valve. Check the strainer in the Relief Valve system.  Remove the control valve and clean.
<b>WATER IN PUMP GEARBOX</b>	Leak coming from above pump	Check all piping connections and tank overflow for possible spillage falling directly on the pump gearbox.  Follow the procedures in Section 3 of this manual for adjustment or replacement of packing. Excess packing leakage permits the flushing of water over the gearbox casing to the input shaft area. Induction of this excessive water may occur through the oil seal or speedometer connection.  If mechanical seal is installed, there should be no leaks. Inspect the oil seal and replace if necessary.
<b>DISCHARGE VALVES DIFFICULT TO OPERATE</b>	Lack of lubrication  Valve in need of more clearance	Recommended weekly lubrication of discharge and suction valve, use a good grade of petroleum base or silicone grease.  Add gasket to the valve cover per the truck manual. Multi-gasket design allows additional gaskets for more clearance and free operation. NOTE: Addition of too many gaskets to the valve will permit leakage.



## 5. CORRECTIVE MAINTENANCE

### A. Midship Pump

#### Tools Required

- Lifting gear-Lever hoist or chain hoist, and short chokers.
- Ball peen hammer
- Center punch
- Allen Wrenches
- Pry bars (2)
- Ratchets and wrenches for disassembly
- Torque wrench, with sockets for cap screws, capable of 40, 65, and 135 ft-lb (54, 88, and 183 N-m)
- Pan (to catch drip oil).
- Disposable-rags and oil dry.

**NOTE:** Due to the nature of a Hale Midship pump most service can be performed without removing the pump assembly from the apparatus.

If a catastrophic failure to the pump (cracked pump body) requires removal of the entire pump assembly from the apparatus use the following procedure.



THE MIDSHIP PUMP AND GEARBOX ASSEMBLY WITH ASSOCIATED COMPONENTS WEIGHS 1,500 LBS. (680 KG) TO 2,000 LBS. (909 KG). MAKE SURE PROPER CAPACITY LIFTING APPARATUS IS PROVIDED TO REMOVE PUMP AND GEARBOX FROM APPARATUS.

#### 1. Removal

- a. Place apparatus out of service in accordance with department procedures.
- b. Remove body panels and framework to gain access to the pump compartment and pump. Make sure there is sufficient clearance above the apparatus to lift the pump and gearbox assembly out of the apparatus.

- c. Remove valve operators, discharge piping suction piping and valves that would interfere with pump removal.
- d. Disconnect drive shafts, airlines, electrical wiring and cooling lines as necessary from the gearbox.
- e. Install 1/2-13UNC eyebolts into lifting holes on the pump body (see figure 5-1). Attach proper lifting gear to these eyebolts.
- f. Locate and remove fasteners that hold the pump to the apparatus chassis frame.
- g. Carefully lift pump and gearbox assembly from apparatus. Place the entire assembly on a work stand of suitable capacity.

**NOTE:** Before beginning removal, you may want to make a sketch of plumbing and component configuration to aid in assembly.

#### 2. Installation

- a. Make sure the chassis mounting point and area around the apparatus is clean and free of obstructions.
- b. Attach suitable lifting device to the pump and gearbox assembly.
- c. Lift pump and gearbox assembly and guide onto apparatus at proper mounting point.
- d. Install and tighten fasteners that secure pump assembly to chassis frame.
- e. Once pump is secure remove lifting device and eyebolts.
- f. Connect all components to gearbox.
- g. Attach valves, suction piping, discharge piping and valve operators.
- h. Reinstall apparatus frame work and body panels.

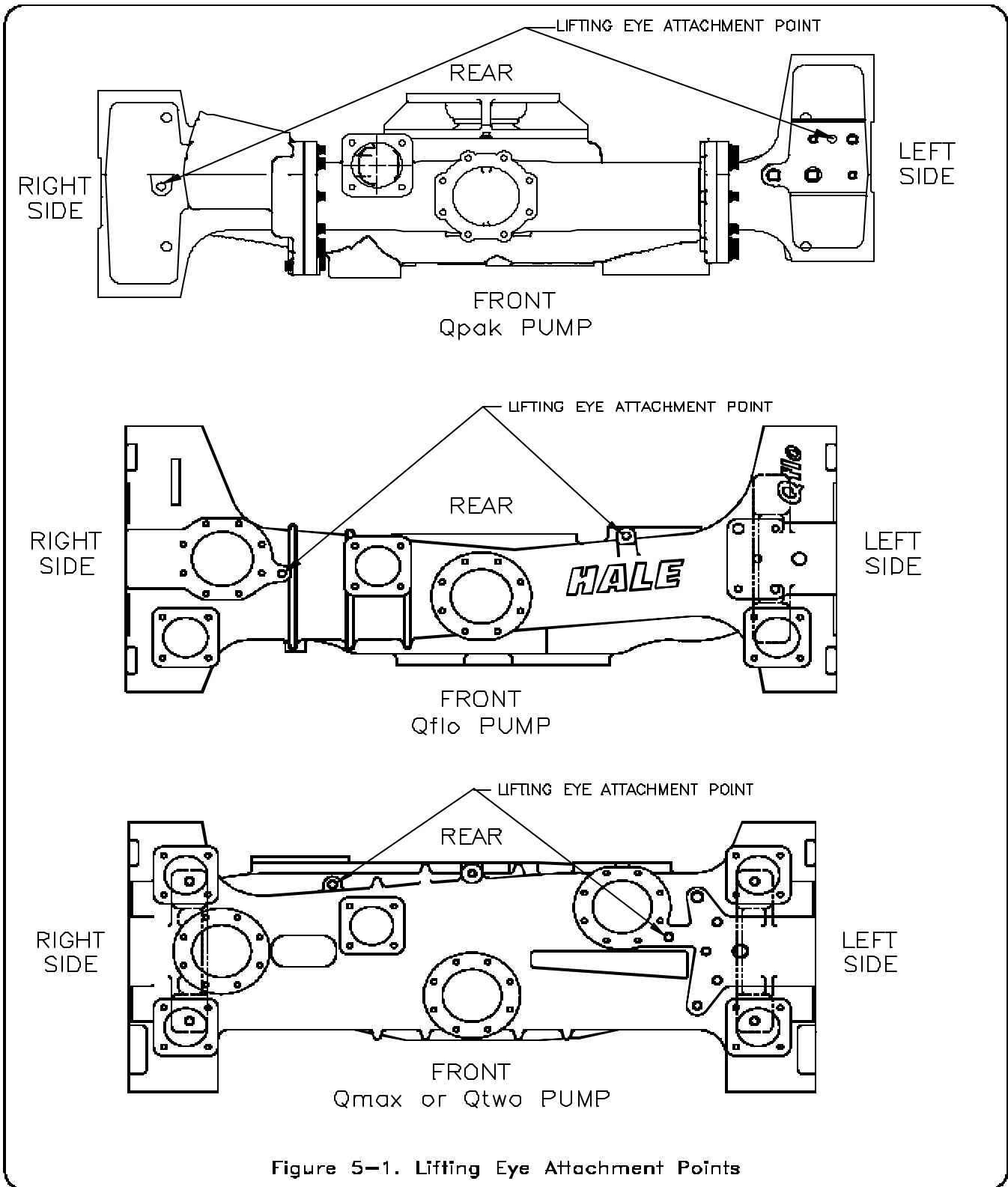

Figure 5-1. Lifting Eye Attachment Points

- i. Test operate apparatus and certify pump performance as required.
- j. Return apparatus to service.

## B. Gearbox

### G-Series

(Refer to figures 5-2 and 5-3)

#### 1. Removal

- a. Place apparatus out of service in accordance with department procedures.
- b. Drain oil, disconnect drive shafts, shift switches, air connection, cooling lines, and tachometer from gearbox as necessary. Make sure to mark connections for reassembly.

 **WARNING**

THE GEARBOX WEIGHT IS ABOUT 500 LBS (228 KG) BEFORE BEGINNING DISASSEMBLY PROPERLY SUPPORT GEARBOX WITH LIFTING GEAR TO AID IN LOWERING GEARBOX AND TO PREVENT PERSONNEL INJURY.

- c. Remove six 1/2-13 x 1-1/2 inch long cap screws on the cover of the gearbox, remove the spacer plate if installed.

**NOTE:** The number of cap screws that hold the rear bearing housing to the gearbox depends on the model gearbox. The short gearbox uses seven cap screws and the long gearbox uses eight cap screws.

- d. Remove 7/16-14 x 1-1/4 inch long cap screws that hold the rear bearing housing to the gearbox. Remove the gearbox cover.
- e. Carefully lower the gearbox from the apparatus. Place a temporary cover over the gearbox to prevent dirt and debris from entering the gearbox. Move gearbox to suitable work area.

- f. After the gearbox is removed, carefully inspect bearings and other parts for excessive wear or damage

Order new components from Hale if replacement is required.

#### 2. Installation

- a. Install a new gasket onto the gearbox seating surface of the rear bearing housing. Apply a light coat of grease to the gasket to hold it on place.
- b. Place a new gasket on the seating surface of the gearbox and gearbox cover. Check the fit of the gasket and carefully trim the gasket to match the contour of the gearbox.
- c. Carefully lift the gearbox into place around the rear bearing housing. Insert two or three 7/16-14 x 1-1/4 inch long cap screws through the rear bearing housing to help hold the gearbox in place.
- d. Position the gearbox cover and insert six 1/2-13 x 1-1/2 inch long cap screws. Tighten cap screws hand tight.
- e. Insert the remainder of the 7/16-14 x 1-1/4 inch long cap screws through the rear bearing housing and gasket into the gearbox and cover. Tighten the 7/16-14 x 1-1/4 inch long cap screws. Torque the 7/16-14 x 1-1/4 inch long cap screws to 40 ft-lb (54 N-m). Tighten the 1/2-13 x 1-1/2 inch long cap screws to 65 ft-lb (88 N-m).
- f. Connect drive shafts, cooling lines, air hoses, and electrical connections to gearbox.
- g. Fill gearbox with oil.
- h. Test operate apparatus observing packing or mechanical seal, oil seal, and gaskets for leaks.

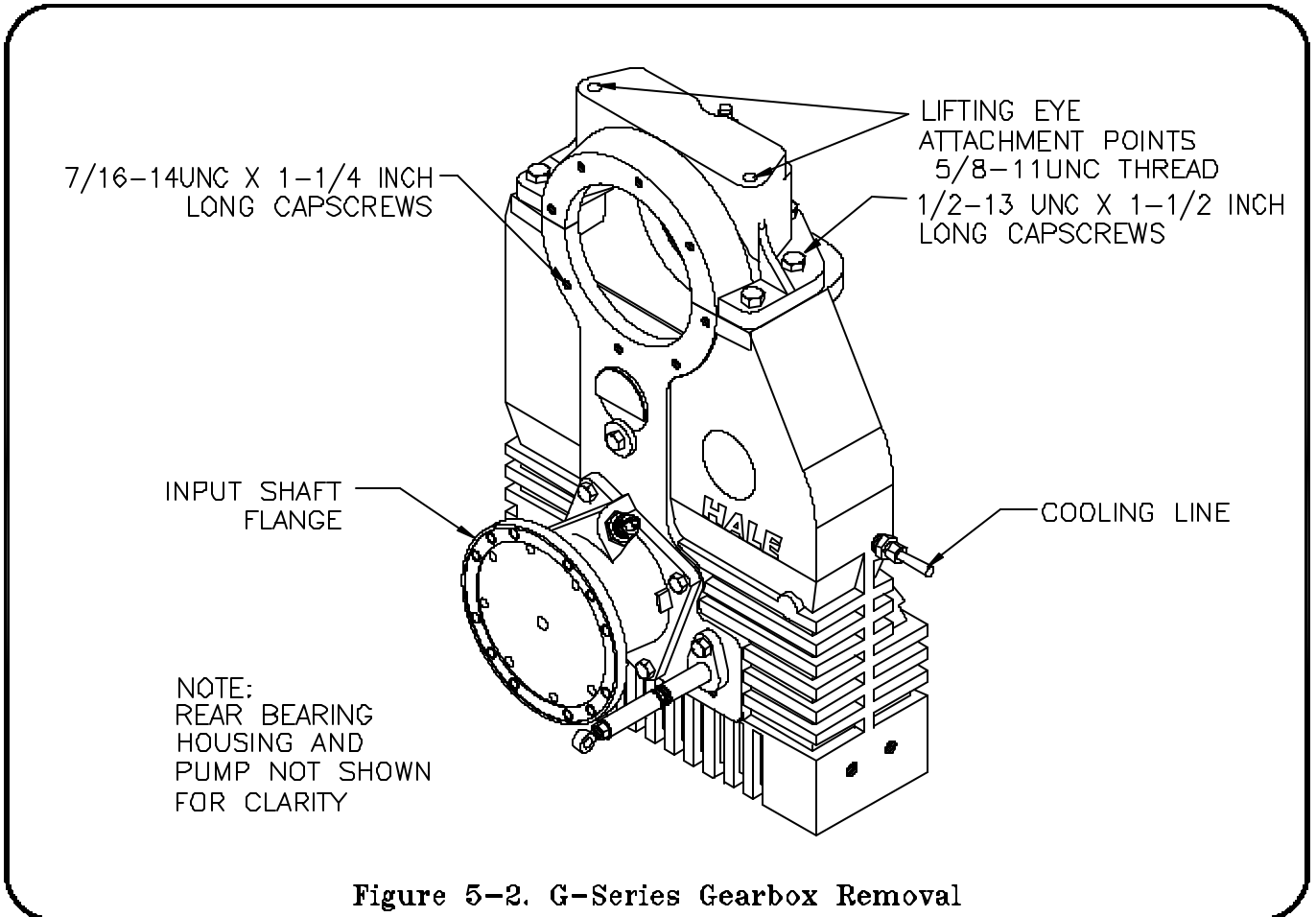

Figure 5-2. G-Series Gearbox Removal



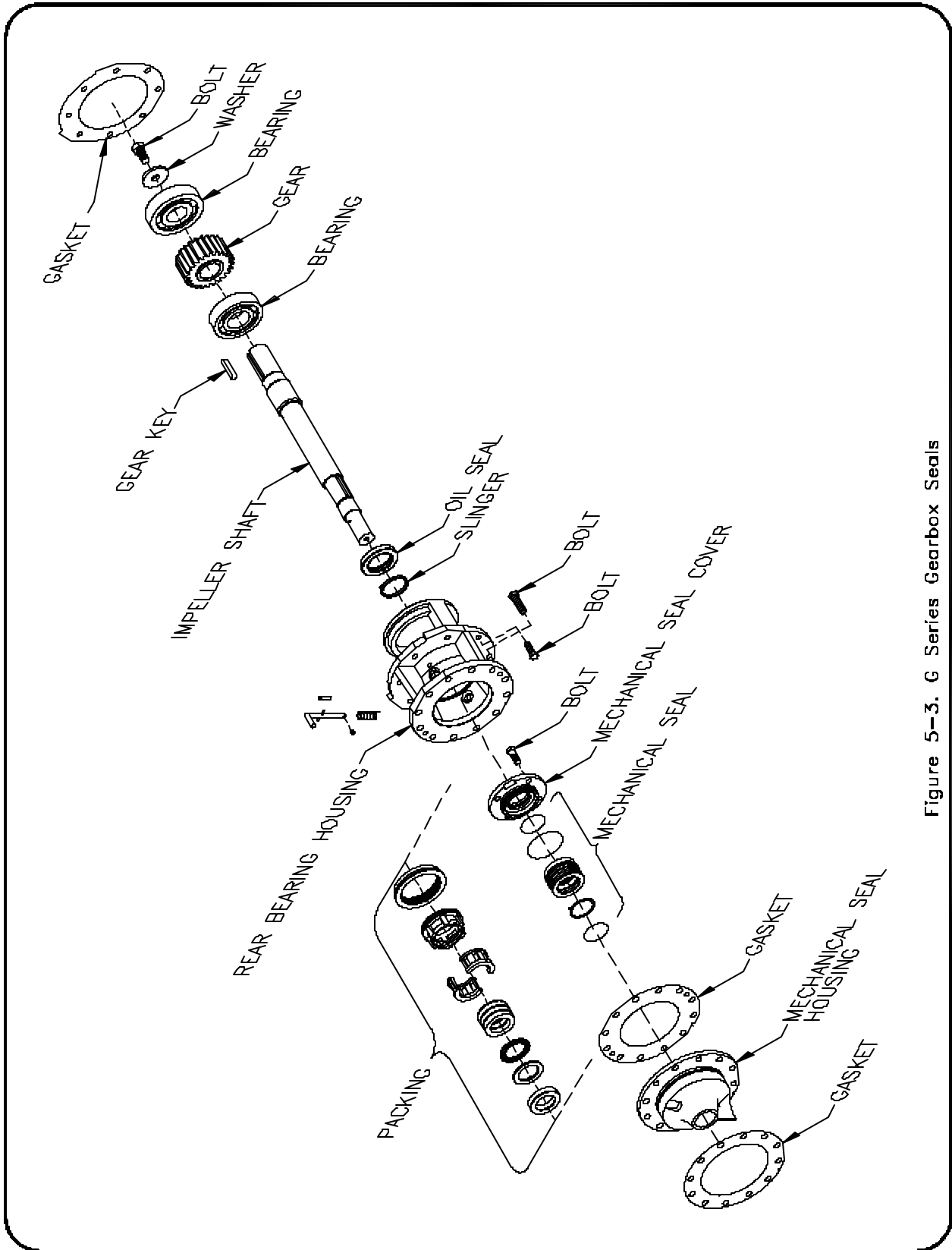

Figure 5-3. G Series Gearbox Seals

## J-Series Gearbox

(Refer to figure 6-6)

### 1. Removal

- a. Place apparatus out of service in accordance with department procedures.
- b. Drain oil, disconnect drive shaft. Make sure to mark connections for reassembly.

### **WARNING**

THE J-SERIES GEARBOX WEIGHS 350 LBS (159 KG). BEFORE BEGINNING DISASSEMBLY, PROPERLY SUPPORT GEARBOX WITH LIFTING GEAR TO AID IN LOWERING GEARBOX AND TO PREVENT PERSONNEL INJURY.

- c. Note the locations and remove eight 1/2-13 cap screws which hold the upper housing and lower housing together.
- d. Carefully lower the lower gearbox housing from the apparatus making sure the spacer (if installed) does not get damaged. Place a temporary cover over the gearbox to prevent dirt and debris from entering the gearbox. Move gearbox to suitable work area.
- e. After the gearbox is removed, carefully inspect dowel pins, bearings and other parts for visible signs of excessive wear or damage. Order new components from Hale if replacement is required.

### 2. Installation

- a. Make sure the dowel pins are properly seated and install new ones if necessary.
- b. Install new gaskets onto the seating surface of the lower gearbox housing. Apply a light coat of grease to the gasket to hold it in place.
- c. Install the spacer, if required, and install a new gasket on the seating surface of the spacer.
- d. Carefully lift the gearbox into place aligning the dowel pins with the holes in the upper gearbox housing.
- e. Insert the eight 1/2-13 cap screws. Tighten cap screws to 65 ft-lb (88 N-m).
- f. Connect drive shaft to gearbox.
- g. Fill gearbox to proper level with oil.
- h. Test operate apparatus observing mechanical seal, oil seal, and gaskets for leaks.

## C. Packing Replacement

When the packing adjustment has been taken up, a single ring of packing can be added. However, it is usually more satisfactory to repack the pump. Refer to figures 1-9 and 5-3 for a cross-section showing the packing arrangement and number of packing rings. The three rings adjacent to the packing gland can be replaced without disassembling the pump. The ring in front of the lantern does not need to be replaced. Repack the pump as follows.

### **WARNING**

**DO NOT RUN ENGINE WHILE MAKING PACKING ADJUSTMENT**

1. Loosen the packing nut lock.
2. Loosen the packing nut. If necessary, soak the threads with penetrating oil and work the nut back and fourth to loosen it. Loosen the adjusting nut just enough to remove the split glands. If the front part of the gland is of the split type, remove the two halves.
3. Remove the old packing rings with a packing hook or blow the packing out. The hook can be made from a bent piece of stiff wire or small pointed rod. Another type of packing hook consists of a corkscrew on the end of a flexible shaft. Be sure to remove all shreds of old packing, and clean out the packing housing as much as possible.
4. Remove all old packing, dirt, and foreign matter from the bearing housing under the packing gland.
5. Repack using the Hale packing kit recommended for your particular pump. For most pumps, the packing is 7/16-inch square cut to the proper length. Wrap one length of packing around the shaft to form a ring, and push the ring into the packing housing. Install the second ring the same way, but stagger the joint one-third of the way around from the first joint. Put foil

separators between each packing ring. The foil separators must be cut to fit the shaft. Install the other rings, again staggering the joints.

6. Replace the gland and adjust it according to the Packing Gland Adjustment procedure in this section.
7. Operate the pump normally for about 15 minutes, and check the packing gland. If necessary, adjust the packing nut according to the Packing Gland Adjustment procedure in Section 3.

## D. Mechanical Seal Replacement

**NOTE:** Before starting disassembly matchmark with a center punch the rear bearing housing, mechanical seal housing, and pump body for proper alignment during reassembly.

### Qmax and Qtwo Pump Mechanical Seal

1. **Removal** (Refer to figure 5-4)
  - a. Remove gearbox in accordance with paragraph B.1, this section.
  - b. Remove the 5/8-11 x 1-1/4 inch long cap screw and bearing retainer washer from the end of the impeller shaft.
  - c. Remove twelve 1/2-13 x 1-3/4 inch long cap screws that hold the rear bearing housing to the pump body.
  - d. Install two 1/2-13 x 2-1/2 inch long cap screws into the 1/2-13UNC threaded holes on the rear bearing housing to use as jacking screws. Install a 1/2-13 x 2-1/2 inch long cap screw into one of the holes on the rear bearing housing into the pump body to keep the mechanical seal housing from rotating while removing rear bearing housing.

**NOTE:** It may be necessary to use prybars to loosen the back bearing and gear before attempting to remove the rear bearing housing.

- e. Slowly and evenly turn the jacking screws clockwise to move the rear bearing housing away from the pump body.
- f. As the rear bearing housing moves back remove the gear and gear key from the impeller shaft and bearing housing as they clear the shaft. Do not allow the weight of the rear bearing housing to rest on the oil seal.
- g. After the gear and key are removed, carefully remove the rear bearing housing from the impeller shaft being careful not to damage the oil seal.
- h. Remove the slinger from the impeller shaft.
- i. Using a center punch, matchmark the mechanical seal cover and mechanical seal housing. Remove four 7/16-14 x 1-1/4 inch long cap screws that secure the mechanical seal cover to the mechanical seal housing.
- j. If necessary, use pry bars in the slots provided to loosen the mechanical seal cover from the mechanical seal housing. Remove the mechanical seal cover from the impeller shaft.
- k. Remove the old mechanical seal from the mechanical seal housing and impeller shaft. Two small hooks will aid in removal of these components.
- l. After all components are removed, carefully inspect bearings and other parts for excessive wear or damage. Order new components from Hale if replacement is required.

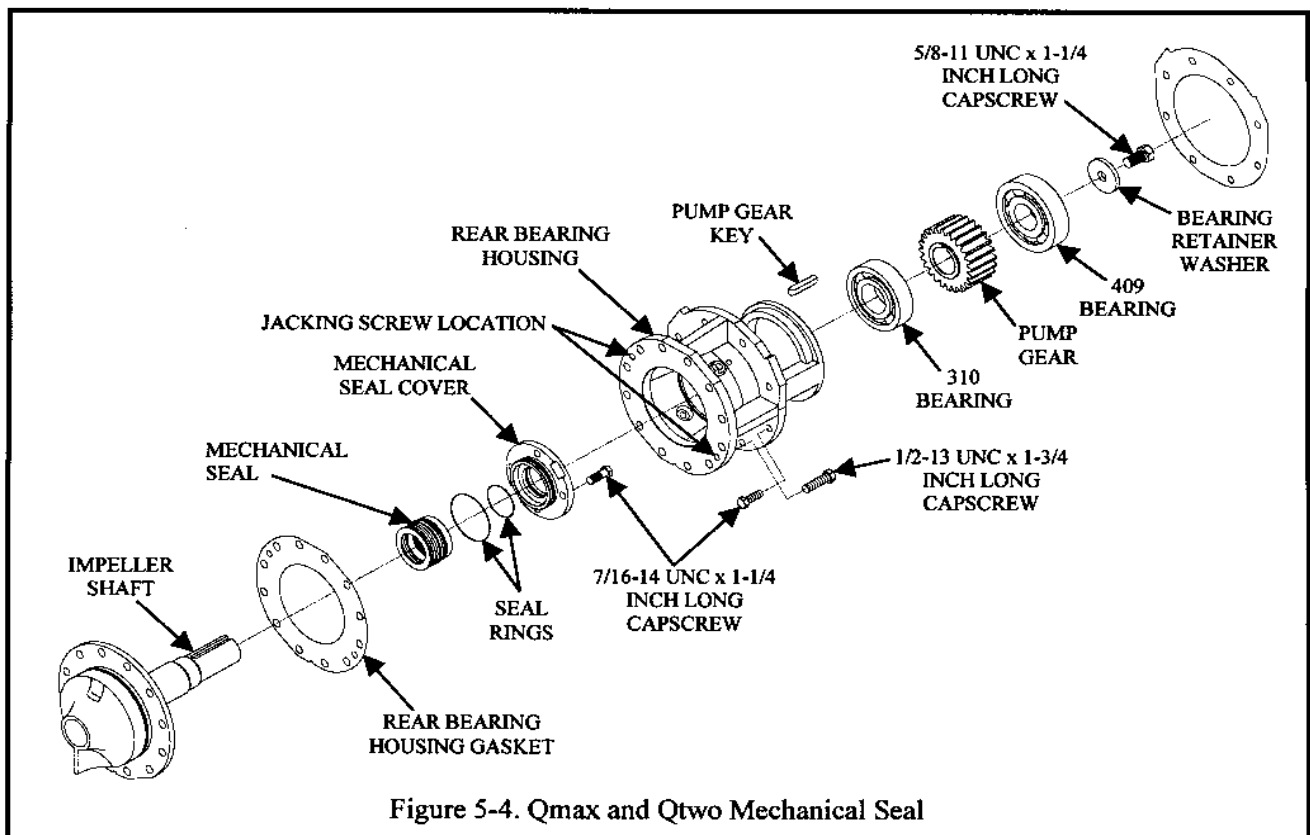

## 1. Installation

### INSTALLATION NOTES:

- ❑ Apply a light coat of grease to the gaskets to hold them in place during assembly. Use only lithium based grease with 1 to % molybdenum disulfide. Some examples of correct greases are: Dow Corning BR2-PLUS, Lubriplate-Fiske #3000, Shell Super Duty Grease, Imperial #777, Mobil - Mobil Grease Special and Sun Oil - Sunoco MOLY #2EP.
- ❑ Apply a light coat of grease to the seal rings before assembly.
- ❑ When installing the cap screws make sure they are locked in place using a suitable thread locking compound such as Loctite #242 or equal.
- ❑ If cap screws require replacement they shall be replaced with grade 5, zinc plated steel, nylon locking type.
- ❑ Oil and grease will damage the Ethylene-Propylene (EPT) bellows on the mechanical seal. Use only Ethylene-Glycol (anti-freeze) or soapy water to lubricate the impeller shaft and bellows during assembly.
- ❑ Do not touch the sealing face of the carbon seal ring or seat while handling or installing the mechanical seal.
  - a. Clean all oil, dirt, and grease from the end of the impeller shaft. Make sure the impeller shaft is smooth and free of burrs at the gear key slot and bearing journals.



OIL AND GREASE WILL DAMAGE THE ETHYLENE-PROPYLENE (EPT) BELLOWS ON THE MECHANICAL SEAL. USE ONLY ETHYLENE-GLYCOL (ANTI-FREEZE) OR SOAPY WATER TO LUBRICATE THE IMPELLER SHAFT AND BELLOWS DURING ASSEMBLY.



DO NOT TOUCH THE SEALING SURFACE OF THE CARBON SEAL RING OR THE METAL SEAT WHILE HANDLING OR INSTALLING THE MECHANICAL SEAL.

**IMPORTANT:** Always replace the entire mechanical seal with a complete new Hale mechanical seal assembly.

- b. Lubricate the inside of the mechanical seal bellows and impeller shaft using Ethylene-Glycol (anti-freeze) or soapy water solution.
- c. Slide new mechanical seal bellows end over the impeller shaft making sure the spring is oriented towards the impeller. Using a soft pusher tube (2 inch PVC pipe) and keeping fingers away from carbon seal ring, carefully push the mechanical seal assembly into the mechanical seal housing. If binding occurs apply more lubricant to the impeller shaft and bellows.
- d. Being careful not to touch the face of the seat, install the cup and seat into the mechanical seal cover. Lubricate the cup and mechanical seal cover with Ethylene-Glycol or soapy water solution.
- e. Replace the seal rings in the grooves on the mechanical seal cover. Apply a light coat of grease to the seal rings being careful not to get grease on the impeller shaft. Slide the mechanical seal cover over the impeller shaft making sure the mechanical seal remains seated in the bore of the cover. Make sure there is no oil or grease on the faces of the mechanical seal.
- f. Screw a 7/16-14UNC stud into one of the holes in the mechanical seal housing to aid in bolt hole alignment.

- g. Insert the mechanical seal cover in mechanical seal housing making sure to line up the bolt holes and center punch marks.
- h. Install four 7/16-14 x 1-1/4 inch long cap screws into the holes. Tighten cap screws evenly and torque to 40 ft-lb (54 N-m). When installing the cap screws make sure they are locked in place using a suitable thread locking compound such as Loctite #242 or equal. If cap screws require replacement they shall be replaced with grade 5, zinc plated steel, nylon locking type.
- i. Slide the slinger onto the impeller shaft.
- j. Install new oil seal into the rear bearing housing.
- k. Place a new gasket over the mating surface of the mechanical seal housing and rear bearing housing. Apply a light coating of grease to the gaskets to hold them in place during assembly. Use only lithium based grease with 1 to 3% molybdenum disulfide. Some examples of correct greases are: Mobile Grease Special and Sun Oil – Sunoco MOLY #2EP.
- l. Install two 1/2-13UNC studs into mechanical seal housing in pump body to aid in alignment of the rear bearing housing. Slide the rear bearing housing over the impeller shaft making sure the oil seal aligns properly. Do not allow the weight of the rear bearing housing to rest on the oil seal. Align the bolt holes and center punch marks.
- m. Insert twelve 1/2-13 x 1-3/4 inch long cap screws into the holes. Evenly tighten the cap screws to 65 ft-lb (88 N-m).
- n. Install 310 bearing onto the impeller shaft and properly seat into bearing housing.
- o. Place the gear key into slot on impeller shaft then install the gear onto the impeller shaft making sure the key lines up with the key way in the gear.
- p. Install 409 bearing over the impeller shaft and properly seat in bearing housing.
- q. Install bearing retainer washer on impeller shaft end and secure using 5/8-11 x 1-1/4 inch long cap screw. Tighten cap screw and torque to 135 ft-lb (183 N-m).
- r. Install gearbox in accordance with paragraph B.2, this section.

### Qflo and Qpak Pump Mechanical Seal and Clearance Rings

#### 1. Removal (Refer to figure 5-5)

- a. Place apparatus out of service in accordance with department procedures.
- b. Open drains and drain pump body.
- c. Drain gearbox oil.
- d. Tag and disconnect air lines and electrical connections.
- e. Disconnect drive shafts.

 **WARNING**

GEARBOX AND IMPELLER ASSEMBLY WEIGHS ABOUT 500 LBS (228 KG). MAKE SURE PROPER LIFTING DEVICES ARE USED FOR REMOVAL AND INSTALLATION OF GEARBOX.

- f. Attach proper lifting device to gearbox.
- g. Remove the twelve 7/16-14UNC X 1-1/4 inch long screws from the bearing housing and pump body.

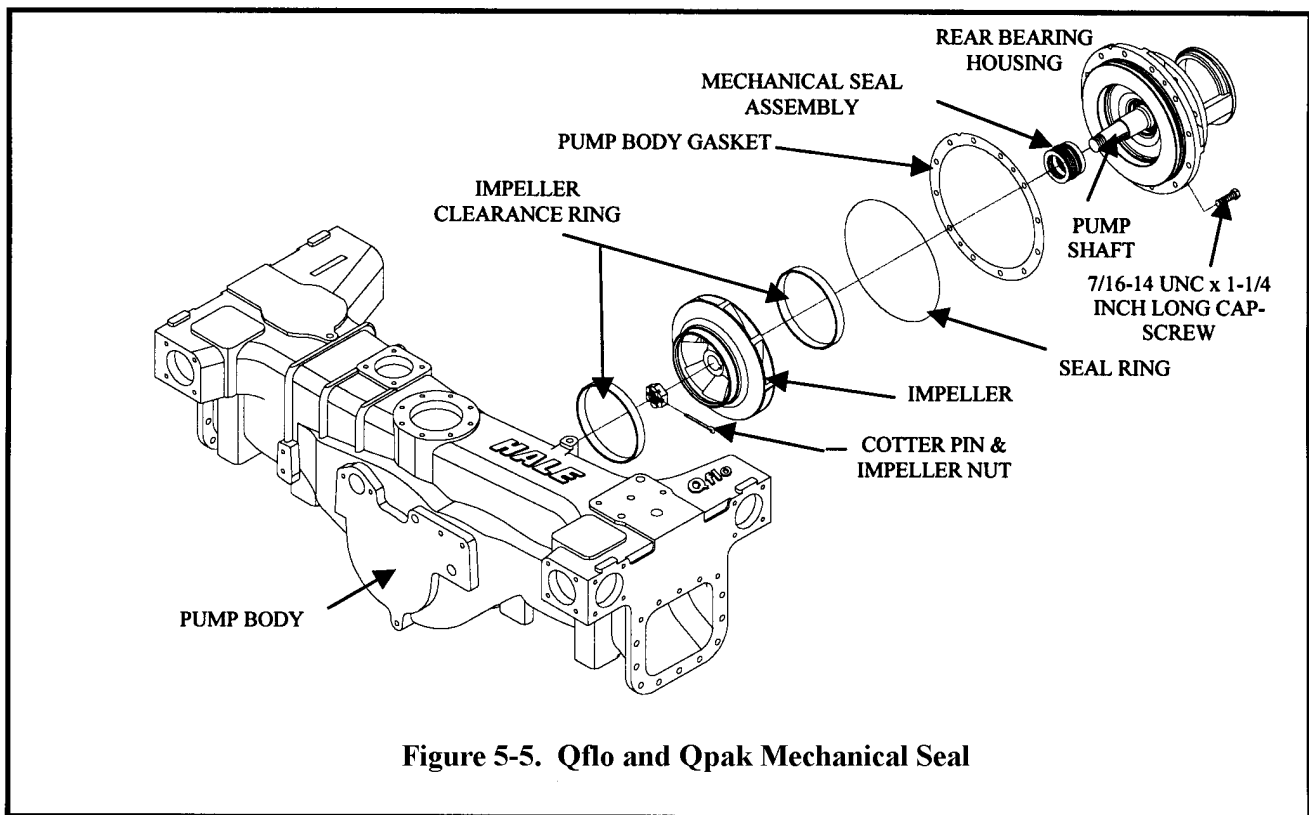

**Figure 5-5. Qflo and Qpak Mechanical Seal**

- h. Install 7/16-14UNC screws into threaded holes on bearing housing to use as jacking screws.
- i. Turn the jacking screws clockwise evenly to back the bearing housing out of the pump body. Make sure the gearbox and bearing housing stay straight as the assembly is backed out.
- j. Remove the gearbox and impeller assembly to a suitable work area.
- k. Remove cotter pin and nut from impeller shaft.
- l. Using a suitable puller remove the impeller and impeller key from the shaft.
- m. Use hooks that fit around the shaft and seal then remove the spring and spring retainer then the remainder of the mechanical seal assembly.
- n. Remove the cup and seat from the bearing housing.
- o. Clean impeller shaft and all components.
- p. Measure the impeller wear surfaces and the wear rings. The wear rings should be replaced if the radial clearance is 0.015 to 0.020 inch per side or overall.
- q. If necessary, remove and replace the wear rings in the pump body and rear bearing housing.
- r. Inspect the oil seal in the rear bearing housing and replace if necessary.





## 2. Installation

### NOTICE

WHEN APPLYING THE ETHYLENE GLYCOL OR SOAP AND WATER SOLUTION, MAKE SURE ALL SHAFT SURFACES AND THE INSIDE OF THE SEALING BOOT ARE COATED.

- a. Being careful not to touch the sealing surface of the mechanical seal seat, apply a solution of ethylene glycol (anti-freeze) or soap and water to lubricate the pump shaft and inside of the seat assembly. Slide the cup and seat assembly over the impeller shaft. Using a soft clean pusher tube (a short length of 2 inch PVC pipe) make sure the cup and seat assembly are seated squarely in the rear bearing housing.
- b. Keeping fingers away from the carbon seal ring apply a solution of ethylene glycol (anti-freeze) or soap and water to lubricate the shaft and inside of the seal bellows. Orient the carbon seal ring towards the seal and slide the bellows and spring over the impeller shaft. Use the pusher tube to make sure the assembly is pushed all the way in. If resistance is felt, add more ethylene glycol (anti-freeze) or soap and water to keep the shaft and bellows lubricated.
- c. Insert impeller key in the impeller shaft and install the impeller on the shaft.
- d. Install impeller nut and tighten to 135 ft-lb (183 N-m) Lock the impeller nut in place using a cotter pin.
- e. Apply a light coating of grease to the seal ring groove and install a new seal ring on the rear bearing housing.
- f. Install a new gasket on the rear bearing housing, holding it in place with a light coating of grease.
- g. Thread two 7/16-14UNC studs in the pump body to help guide the rear bearing housing onto the pump body.
- h. Using proper lifting device lift gearbox and impeller assembly into place. Use studs to guide the rear bearing housing into the pump body.
- i. Insert the 7/16 –14UNC X 1-1/4 inch long cap screws into the rear bearing housing. Tighten screws to 40 ft-lb (58 N-m) torque.
- j. Reconnect drive shafts, electrical, and air lines to gearbox.
- k. Refill the gearbox with oil.
- l. Test operate apparatus and watch for leaks.

## E. AutoLube® Service (Qmax/Qtwo)

1. Park the vehicle on a level surface. Shut down the engine. Set the parking brake and chock the front and rear wheels.
2. Drain water from the pump.
3. Remove the fill and drain plugs from the AutoLube® reservoir and drain oil.
4. Use a center punch to mark the AutoLube® cover and the front bearing cover housing (for proper alignment during assembly).

## CAUTION

DO NOT USE A CHISEL TO SEPARATE THE AUTOLUBE® FROM THE PUMP BODY BECAUSE THE MATING SURFACES MAY BE SCRATCHED OR GOUGED, WHICH COULD RESULT IN A LEAK. ALSO, THE AUTOLUBE® IS MANUFACTURED FROM CAST METAL, BODY, PRY BETWEEN THE AUTOLUBE® AND THE PUMP BODY OR AT THE AND IF IT BECOMES NECESSARY TO PRY THE AUTOLUBE® APART FROM THE PUMP AUTOLUBE® "NOTCHES"

5. Remove the cap screws attaching the AutoLube®, figure 5-6, to the pump body and gently pry AutoLube® from the pump body and impeller shaft.

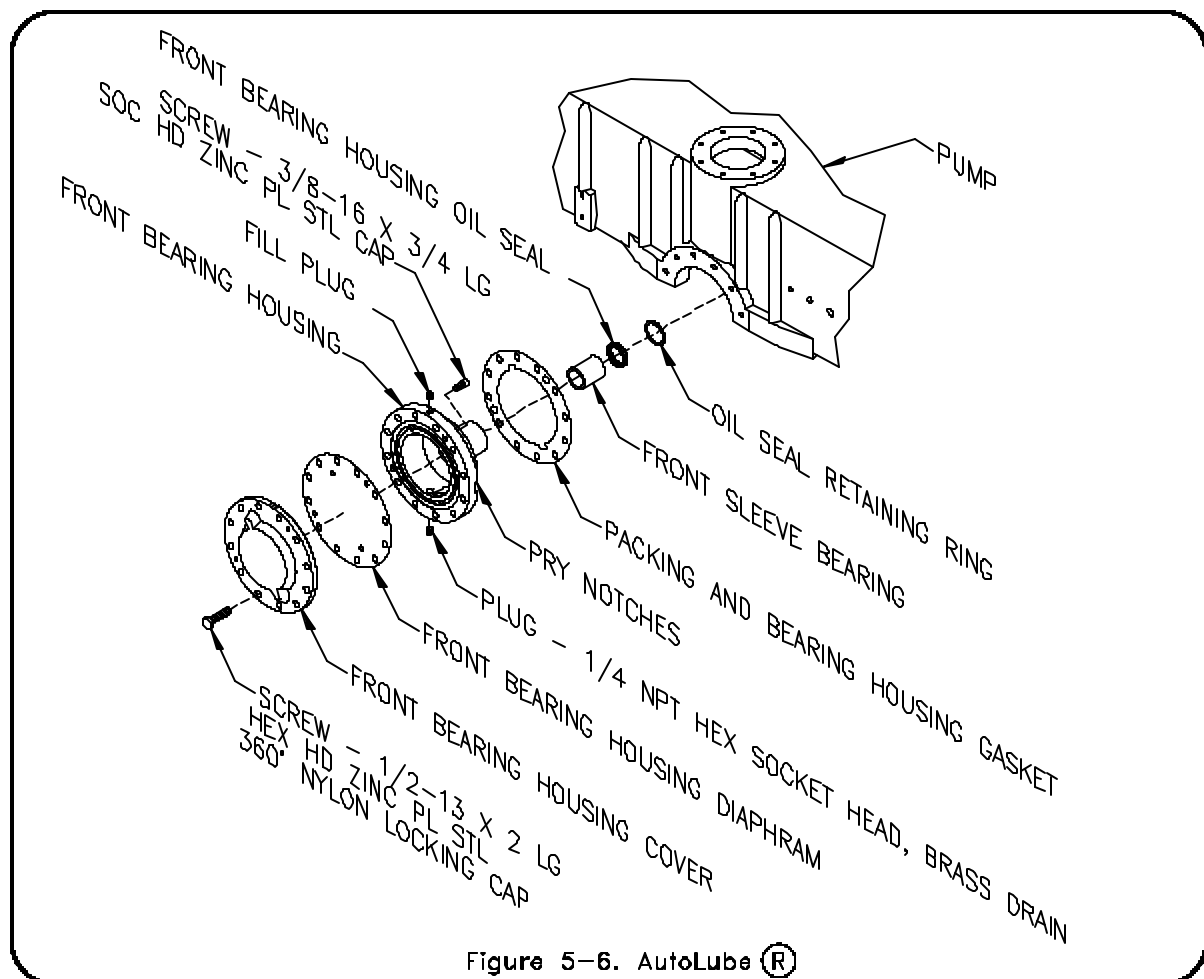

Figure 5-6. AutoLube®

6. Place the AutoLube® face down on a work bench and remove the two allen-head cap screws from the impeller side. Separate the two halves and remove the diaphragm.
7. Remove the oil seal lock ring.
8. Remove the oil seal from the inner half of the AutoLube®.
9. Check the impeller shaft bushing for wear.
10. Clean the inner and outer halves of the AutoLube®.
11. Clean the gasket surfaces of the AutoLube® and pump body.
12. Check for restrictions in the water passages to the rear half of the AutoLube®.
13. If it is necessary to replace the impeller shaft bushing, press the bushing from the inner side of the inner half of the AutoLube® (on the side opposite of the impeller). Install the bushing from the impeller side of the inner half of the AutoLube®. See figure 5-6.

 **CAUTION**

THE IMPELLER SHAFT BUSHING SEATS AGAINST A SHOULDER IN THE INNER HALF OF THE AUTOLUBE® AND CAN ONLY BE REMOVED AND INSTALLED AS DIRECTED OR THE AUTOLUBE® MAY BE DAMAGED.

14. Install the new oil seal in the inner half of the AutoLube®.
15. Install the seal lock ring.
16. Position the diaphragm on the inner half of the AutoLube®.
17. Line up the marks, and place the outer half of the AutoLube® onto the inner half. Apply Loctite® 242 to the two allen-head cap screws. Tighten to 26 ft-lb (35 N-m).

18. Install the new gasket on the AutoLube®, and position the assembly (with the top up) onto the impeller shaft. Attach the AutoLube® with cap screws and tighten to 64 ft-lb (87 N-m).

 **CAUTION**

DO NOT DAMAGE THE OIL SEAL. A DAMAGED OIL SEAL COULD RESULT IN DAMAGE TO THE AUTOLUBE® ASSEMBLY, AS WELL AS THE PUMP.

 **CAUTION**

PURGE THE AIR FROM THE AUTOLUBE® WHILE FILLING IT WITH OIL OR A “FALSE-FILL” SITUATION WILL DEVELOP, WHICH COULD CAUSE DAMAGE TO THE AUTOLUBE® AND OTHER COMPONENTS

19. To fill the AutoLube® with 90w oil, pump the oil in from the bottom plug opening until the oil spills from the top opening. This eliminates air pockets and false readings.
20. Add water to the pump.
21. Operate the fire pump and check the AutoLube® for water or oil leaks.
22. Remove the tire chocks.
23. Return apparatus to service.

## F. Impeller Assembly

### 1. Impeller and Clearance Rings Removal

(Qmax (refer to Figure 6-3 and Qtwo Pumps (Refer to Figure 6-4)

- a. Park the vehicle on a level surface. Shut down the engine. Set the parking brake and chock the front and rear wheels.
- b. Drain the water from the pump.

#### **WARNING**

THE GEARBOX ASSEMBLY WEIGHS 500 LBS (228 KG). SUPPORT THE LOWER GEARBOX ASSEMBLY WITH A LIFTING DEVICE. FAILURE TO DO SO COULD RESULT IN THE ASSEMBLY FALLING, WHICH COULD RESULT IN PERSONAL INJURY OR PROPERTY DAMAGE.

- c. Remove the gearbox, refer to paragraph B.1, this section.

#### **WARNING**

THE LOWER PUMP BODY WEIGHS 100 LBS (46 KG). SUPPORT THE LOWER PUMP BODY AND IMPELLER ASSEMBLY WITH A LIFTING DEVICE. FAILURE TO DO SO COULD RESULT IN THE LOWER PUMP BODY AND IMPELLER ASSEMBLY FALLING, WHICH COULD RESULT IN PERSONAL INJURY, OR PROPERTY DAMAGE.

- d. Remove the drain lines from the lower pump body.
- e. Mark lower pump body, Autolube® housing, and rear bearing housing for reassembly.
- f. Drain the oil from the AutoLube®, and remove the 1/2-13UNC X2 inch long cap screws from the upper half of the AutoLube® and pump body.

- g. Remove the 1/2-13UNC X 1-3/4 inch long cap screws from the upper half of the rear bearing housing and pump body.
- h. Remove the 1/2-13UNC X 1-1/4 inch long cap screws, from the lower pump body.

#### **WARNING**

DO NOT REMOVE THE FOUR CAP SCREWS, ONE IN EACH CORNER OF THE LOWER PUMP BODY, UNTIL THE LIFTING DEVICE IS IN POSITION. FAILURE TO DO SO COULD RESULT IN THE LOWER PUMP BODY AND IMPELLER ASSEMBLY FALLING, WHICH COULD RESULT IN PERSONNEL INJURY OR PROPERTY DAMAGE.

- i. Position the lifting device into place with the lower pump body-lifting adapter between the lifting device and the lower pump body.
- j. Remove the 5/8-11UNC X5 inch long cap screws in each corner of the lower pump body.
- k. Lower the lower pump body and impeller assembly so that it does not tip from the lifting device. Remove the assembly to a suitable work area.
- l. Remove the remaining cap screws from the lower half of the AutoLube®, the rear bearing housing, and the lower pump body.

#### **WARNING**

THE IMPELLER ASSEMBLY IS HEAVY. DO NOT ATTEMPT TO LIFT THE ASSEMBLY WITHOUT THE AID OF ANOTHER PERSON OR PERSONS. FAILURE TO DO SO COULD RESULT IN THE IMPELLER ASSEMBLY FALLING, WHICH COULD RESULT IN PERSONNEL INJURY OR PROPERTY DAMAGES.

- m. Remove the remaining screws from the rear bearing housing, and the lower pump body.
- n. Lift the impeller assembly from the lower pump housing. Set the assembly aside.
- o. Clean the gasket surfaces of the upper and lower pump bodies, as well as those on the AutoLube® and the rear bearing housing face.
- p. Clean the clearance ring and clearance ring seats in both the upper and lower pump body halves to remove all the “build up” material so that the new clearance ring will seat properly.

**NOTE:** Pitting of the clearance rings may occur from the “build up” of material and the effects of corrosion. Once the seats are cleaned, any pitting on the clearance rings is considered normal.

## 2. Disassembly (Single-Stage Pump)

- a. Place the impeller shaft assembly on a workbench. Note the orientation of impeller vanes and clearance rings.
- b. Carefully remove the AutoLube® assembly from pump shaft end.
- c. Remove the outer retaining ring and outer clearance ring.

**NOTE:** Before removing impeller, note the orientation of vanes for proper reassembly. The vanes will turn in a clockwise manner when viewed from the front.

 **WARNING**

WEAR PROTECTIVE, HEAT-RESISTANT GLOVES WHILE HEATING THE IMPELLER TO REMOVE OR INSTALL IT INTO THE IMPELLER SHAFT. HEATED METAL CAN CAUSE INJURY TO YOUR HANDS.

 **CAUTION**

DO NOT OVER HEAT THE IMPELLER. THE IMPELLER IS CONSTRUCTED OF BRONZE. IF THE IMPELLER IS OVERHEATED (AND TURNS RED OR BLUE DURING REMOVAL FROM THE SHAFT), IT HAS BEEN WEAKENED AND MUST BE REPLACED.

- d. Using an acetylene torch, carefully heat the “eye” and hub of the impeller in an even fashion for approximately two minutes.
- e. When heated properly, the impeller should be removed from the shaft using a gear puller. If the impeller moves but does not slide free, do not immediately reheat. Allow the complete assembly to cool to room temperature, then reheat and continue removing the impeller.
- f. Allow the components to cool to room temperature.
- g. Remove the inner clearance ring.
- h. Remove the impeller key.

## 3. Assembly (Single-Stage Pump)

- a. Clean the impeller shaft and the keyway.
- b. Check the water way in the seal housing for restrictions.
- c. Install the inner retaining ring.
- d. Install the new gasket on the seal housing face.
- e. Verify the key is free to slide in the impeller keyway, then install the key into the keyway.

 **CAUTION**

IF THE IMPELLER OR CLEARANCE RINGS ARE DROPPED, DAMAGED OR DEFORMED, THEY WILL NEED TO BE REPLACED.

- f. Install the inner clearance ring over the impeller shaft with proper orientation.

 **WARNING**

WEAR PROTECTIVE, HEAT-RESISTANT GLOVES WHILE HEATING THE IMPELLER TO INSTALL IT INTO THE IMPELLER SHAFT. HEATED METAL CAN CAUSE INJURY TO YOUR HANDS.

- g. Using the torch, heat the “eye” and hub of the new impeller in an even fashion for approximately two minutes. Then, slide the impeller onto the shaft with vanes in proper orientation. (Note: vanes will turn in clockwise direction when viewed from the front of the impeller assembly). If the impeller does not fully slide onto the shaft allow the assembly to cool to room temperature before re-heating.
- h. Install the outer retaining ring.
- i. Install the outer clearance ring in the proper orientation.
- j. Carefully slide the AutoLube® assembly over pump shaft.
- k. Install the impeller shaft assembly on the pump.

**4. Disassembly (Two-Stage Pump)**

- a. Remove AutoLube® assembly from front of impeller shaft.

**IMPORTANT:** Mark the impellers as to whether they are the primary or secondary impeller in relation to the AutoLube®. Improper or backward installation of the impellers affects pump performance.

- b. Place the impeller shaft assembly on a workbench. Note position of impellers and mark for reassembly.
- c. Remove impeller retaining rings.

 **WARNING**

WEAR PROTECTIVE, HEAT-RESISTANT GLOVES WHILE HEATING THE IMPELLER TO REMOVE OR INSTALL IT INTO THE IMPELLER SHAFT. HEATED METAL CAN CAUSE INJURY TO YOUR HANDS.

 **CAUTION**

DO NOT OVER HEAT THE IMPELLER. THE IMPELLER IS CONSTRUCTED OF BRONZE. IF THE IMPELLER IS OVERHEATED (AND TURNS RED OR BLUE DURING REMOVAL FROM THE SHAFT), IT HAS BEEN WEAKENED AND MUST BE REPLACED.

- d. With an acetylene torch, carefully heat the “eye” and hub of the first impeller in an even fashion for approximately two minutes.
- e. When heated properly, remove impeller from shaft using a gear puller. If the impeller moves but fails to slide free, do not immediately reheat. Allow the complete assembly to cool to room temperature, then reheat and continue removing the impeller.
- f. Remove the center support bearing. Then rotate the impeller shaft assembly end for end and heat and remove the second impeller.
- g. Remove the impeller key.

## 5. Assembly (Two-Stage Pump)

- a. Clean the impeller shaft, the keyway, and the seal housing and face.
- b. Check the waterway in the seal housing for restrictions.
- c. Install the new gasket on the seal housing face.
- d. Install the key into the keyway.

### CAUTION

IF THE IMPELLERS OR THE CLEARANCE RINGS ARE DROPPED, DAMAGED OR DEFORMED, THEY WILL NEED TO BE REPLACED.

- e. Install the inner clearance ring with proper orientation.

### WARNING

WEAR PROTECTIVE, HEAT-RESISTANT GLOVES WHILE HEATING THE IMPELLER TO INSTALL IT INTO THE IMPELLER SHAFT. HEATED METAL CAN CAUSE INJURY TO YOUR HANDS.

- f. Using the torch, heat the “eye” and hub of each impeller for approximately two minutes. Then, slide the individual impellers onto the shaft making sure they are in the correct orientation. Make sure the center support bearing is installed between impellers. If an impeller does not fully slide onto the shaft allow the assembly to cool to room temperature before reheating.
- g. Install the outer retaining ring.
- h. Install the outer clearance ring with proper orientation.
- i. Slide AutoLube® assembly over pump shaft.

## 6. Installation (Impeller and Clearance Rings)

- a. Install the pump body gaskets to the lower pump body, trimming as necessary to fit.

### CAUTION

FAILURE TO LINE UP THE CLEARANCE RING LOCK NOTCHES WITH THE PUMP BODY TABS (AS DESCRIBED IN THE NEXT STEP) MAY RESULT IN PUMP DAMAGE AND PUMP FAILURE.

- b. Install the impeller assembly into the lower pump housing, carefully aligning the clearance ring lock notches with the clearance ring lock tabs in the lower pump body. Then, rotate the clearance rings to one side to open up lock notches to line up with the lock tabs in the upper pump body.
- c. through the rear bearing housing and the seal housing. Do not tighten.
- d. Install the 1/2-13UNC X2 inch long cap screws into the AutoLube® housing and lower pump body.
- e. Make sure the dowel pins are in the upper pump body to assist in aligning the lower pump body with the upper pump body.
- f. Using a lifting device, slowly raise the lower pump body and the impeller assembly into place, making sure that the lower pump body aligns with the dowel pins and the clearance ring notches align with the clearance ring lock tabs in upper pump body.
- g. Rotate the impeller shaft and check for freedom of movement when the lower pump body and the impeller assembly is in place.



- h. Apply Loctite 242 and install the four 5/8-11UNC X5 inch long cap screws (one in each corner of the lower pump body). Tighten snug but do not fully torque.
- i. Install the 1/2-13UNC X 1-3/4 inch long screws in the rear bearing housing and mechanical seal housing, also install the 1/2-13UNC X2 inch long cap screws into the AutoLube®. Tighten to 53 ft-lb (72 Nm).
- j. Remove the lifting device.
- k. Apply Loctite 242 to the 1/2-13UNC X 1-3/4 inch long screws, lower pump body cap screws and install them. Tighten snug but do not fully torque.
- l. Torque the 5/8-11UNC X5 inch long cap screws to 150 ft-lb (203 Nm), then, starting from the center and moving outward tighten the lower pump body cap screws to 65 ft-lb (88 Nm).

 **WARNING**

THE GEARBOX ASSEMBLY WEIGHS OVER 500 LBS (228 KG). SUPPORT THE LOWER GEARBOX ASSEMBLY WITH A LIFTING DEVICE. FAILURE TO DO SO COULD RESULT IN THE ASSEMBLY FALLING, WHICH COULD RESULT IN PERSONAL INJURY OR PROPERTY DAMAGE.

- m. Install the gearbox, refer to paragraph B.1, this section.
- n. Operate the pump and check for leaks.

## G. Relief Valve Systems

### 1. PM/PMD Control Valve (Refer to figure 6-14)

- a. Park the vehicle on a level surface. Shut down the engine. Set the parking brake and chock the front and rear tires.
- b. Drain the fire pump. Tag and disconnect wires to indicator light.
- c. Rotate the adjustment handwheel counterclockwise to remove the spring tension.
- d. Remove the cap screw and nut attaching the adjustment handwheel to the adjustment shaft. Then, remove the handwheel.

### CAUTION

IDENTIFY AND MARK THE LINE CONNECTIONS ON THE CONTROL BODY BEFORE REMOVING IMPROPER CONNECTION OF LINES MAY RESULT IN THE FAILURE OF THE PILOT VALVE, WHICH COULD CAUSE DAMAGE TO THE FIRE PUMP.

- e. Remove the pump discharge pressure line and the relief valve line from the control body of the pilot valve.
- f. While holding the pilot valve, remove the four 1/4-20UNC X5/8 inch long machine screws attaching the valve and cover plate to the Pump Operator's Panel, and separate the valve, plate, and the relief valve setting indicator (if equipped with PMD) from the panel.
- g. Disassemble the Control Valve.
  - 1) Remove the four 5/16-18UNC X 1 inch long allen-head cap screws securing the control body to the rear of the spring housing. Then, remove the control body.

### CAUTION

DO NOT USE PLIERS TO UNSCREW THE CONTROL VALVE FROM THE DIAPHRAGM CLAMP. DAMAGE TO THE CONTROL VALVE WILL RENDER THE PILOT VALVE INOPERATIVE.

- 2) Unscrew the control valve from the diaphragm clamp. Remove the diaphragm washer and the diaphragm.
- 3) Remove the retaining ring, the seal and the bearing.

### WARNING

USE A SPRING COMPRESSOR TO REMOVE THE CONTROL SPRING. THE SPRING IS UNDER COMPRESSION, AND COULD BECOME UNCOMPRESSED, WHICH COULD RESULT IN PERSONNEL INJURY.

- 4) Turn the adjustment handwheel clockwise to unscrew the adjustment shaft from the adjustment nut. From the handwheel end, remove the adjustment shaft from the spring housing.
- 5) Remove springs, the adjustment nut, and diaphragm clamp as an assembly from the spring housing, and then separate.
- h. Clean all the control components. Inspect and lubricate with grease the threads on the adjustment shaft.
- i. Assemble the control valve.

**⚠ WARNING**

USE A SPRING COMPRESSOR TO INSTALL THE PILOT VALVE SPRING. COMPRESSION, AND COULD BECOME UNCOMPRESSED, WHICH COULD RESULT IN PERSONAL INJURY.

**⚠ CAUTION**

ALWAYS REMOVE THE PILOT VALVE DISCHARGE PRESSURE STRAINER, WHICH IS LOCATED IN THE TOP OF THE DISCHARGE SIDE OF THE PUMP. CLEAN OR REPLACE, AS NECESSARY. FAILURE TO DO SO COULD RENDER THE PILOT VALVE INOPERATIVE.

- 1) Combine both springs, the adjustment nut, and the discharge clamp as an assembly and install into the spring housing. Align the guide pin adjustment nut with the slot in the spring housing.
  - 2) Slide the adjustment shaft into the spring housing from the handwheel end. Turn the adjustment handwheel counterclockwise in order to screw the adjustment shaft into the adjustment nut until it bottoms in the diaphragm clamp. Do not put the springs under tension.
  - 3) Lubricate the new bearing, and slide the new bearing and bearing washer over the adjustment shaft into the spring body housing. Install the retaining ring. Then, install the new seal washer and rotate the adjustment shaft in both directions to check for freedom of movement.
  - 4) Install the new diaphragm washer and diaphragm. Screw the control valve into the diaphragm clamp.
  - 5) Install the control body. Apply Loctite 242 to the four 5/16-18UNC X 1 inch long allen-head cap screws attaching the control body to the rear of the spring housing.
  - j. Holding the pilot valve, and PMD indicator assembly if installed, align the cover plate and install the four 1/4-20UNC X 1 inch long allen-head cap screws attaching the spring housing to the pump panel.
  - k. Install the pump discharge pressure line and relief valve line to control body of the pilot valve, attach electrical wires to the indicator light.
  - l. Slide the adjustment handwheel onto the adjustment shaft, and then install the retaining cap screw and nut.
  - m. Fill the pump and test the valve for proper operation and leaks.
- 2. QD Relief Valve**  
(Refer to figure 6-15)
- a. Drain the pump.
  - b. Note the location of the wires and disconnect the indicator light switch.
  - c. Disconnect the relief valve supply line from the pilot valve and drain the line.
  - d. Remove the two 7/16-14UNC X 1-1/4 inch long cap screws attaching the relief valve indicator light switch and the mounting bracket assembly to the relief valve cover. Remove the light switch and the bracket.
  - e. Compress the relief valve return spring (by hand), and remove the E-clip and washer. Then, remove the return spring.

- f. Remove the two remaining 7/16-14UNC X 1-1/4 inch long cap screws retaining the relief valve cover to the pump body. Using a twisting motion, carefully remove the relief valve cover

 **CAUTION**

DO NOT PUSH THE RELIEF VALVE TOO FAR INTO THE PUMP BODY AS IT MAY FALL INTO THE PUMP BODY AND BECOME LODGED OR DAMAGED. THE RELIEF VALVE IS MADE OF BRASS AND IS EASILY DAMAGED BY PRYING OR HAMMERING. DAMAGED VALVES MUST BE REPLACED.

- g. Remove the retaining ring securing the relief valve piston to the relief valve. Gently push the relief valve into the pump body approximately 1 inch (25 mm), and then pull it back out in a snap motion. This should pop the relief valve piston out of the relief valve body. Repeat if necessary.

**NOTE:** It is not necessary to remove the relief valve unless it is damaged. To remove the relief valve, the relief valve body will have to be removed and the complete relief valve assembly will need to be replaced (as it will be necessary to pry the relief valve body from the pump body, which will likely damage it).

- h. Clean and inspect all of the relief valve assembly components.
- i. Clean all sealing surfaces and install new O-rings and quad ring seals.
- j. Install the relief valve piston in the stem of the relief valve. Do not push the relief valve into the pump body. As it is necessary to start the piston onto the relief valve stem, push the piston until you can grasp the relief stem. Then, pull the relief valve stem outward while pushing on the relief valve piston. Once the relief valve piston is seated against the shoulder of

the relief valve stem, install the retaining ring.

- k. Operate the relief valve by hand to check freedom of movement.
- l. Slide the relief valve cover gasket and cover over the top of the relief valve stem to align the relief valve supply line from the pilot valve in the original position. Then, apply Loctite 242 to two 7/16-14UNC X 1-1/4 inch long cap screws and install opposite of each other. Tighten, but do not torque.
- m. Compress and install the return spring, and secure it with a washer and E-clip.
- n. Align the indicator light switch bracket with the two empty holes in the relief valve cover. Install the two remaining 7/16-14UNC X 1-1/4 inch long cap screws. Tighten all cap screws to 53 ft-lb (72 Nm).
- o. Connect the relief valve supply line from the pilot valve. Also, connect the drain line.
- p. Assemble indicator light switch and the switch strap. Securely tighten the two screws.
- q. Install the switch strap and light switch in the switch bracket. Leave the two screws attaching the switch strap to the switch bracket slightly loose to allow the switch to move in and out for adjustment.
- r. Connect the panel mounted indicator light or a suitable test light to the switch terminals. With the light switch plunger not in contact with the end of the poppet, the light should be lit.
- s. With the pump not running and the relief valve fully closed, push the light switch in until the switch plunger makes contact with the end of the



poppet and the light goes out. The switch is now in the proper position. Tighten the screws holding the switch strap to the bracket.

- t. Fill the pump and test the valve for proper operation and leaks.

**3. QG Relief Valve**  
(Refer to figure 6-16)

- a. Before removal match mark the relief valve housing and pump body for proper assembly.
- b. Disconnect the line to the sensing valve and drain valve. Make note of the wire connections.
- c. Disconnect the indicator light switch.
- d. Remove the four 7/16-14UNC X 1-1/4 inch long cap screws attaching the relief valve assembly to the pump body.
- e. Using a twisting motion, remove the relief valve assembly.
- f. To disassemble the valve, remove the indicator light switch, remove the cover-retaining ring and slide the cover out of the relief valve body.
- g. Apply a small amount of pressure to the relief valve piston and remove the piston-retaining ring. Carefully release the pressure held to the piston by the spring.
- h. Remove the relief valve stem from the opposite end, sliding the relief valve stem out of the piston.
- i. Reach through the center hole of the piston and pull the piston out of the indicator switch end of the relief valve body. Then, remove the piston spring.
- j. To assemble and install the valve, first clean and inspect all components.

- k. Clean all sealing surfaces and install new O-ring seals.
- l. Install the relief valve into the relief valve body.
- m. Install the piston spring by sliding the piston into the relief valve body while at the same time sliding the piston onto the relief valve stem.
- n. Apply light pressure to the piston to compress the piston spring and install the piston-retaining ring.
- o. Slide the cover into the relief valve body. Then, install the cover-retaining ring.
- p. Slide the relief valve assembly into the pump body with the side marked "top" up, being careful not to damage the O-rings.
- q. Apply Loctite 242 to the four 7/16-14UNC X 1-1/4 inch long cap screws and install the assembly in the pump body. Tighten to 53 ft-lb (72 Nm).
- r. Install collet fitting tight into the valve cover. Back off 1 to 1-1/2 turns.
- s. Install the light switch in the collet fitting. Leave the collet holding the light switch slightly loose to allow the switch to move in and out for adjustment.
- t. Connect the panel mounted indicator light or a suitable test light to the switch terminals. With the light switch pulled nearly all the way out, the light should be lit.
- u. With the pump not running and the relief valve fully closed, push the light switch in until the light goes out. Hold the collet fitting with a wrench to prevent it from turning, and tighten the collet.



- v. Disconnect the electrical connector. Tighten the entire collet fitting 1 to 1-1/2 turns. The switch is now in the proper position. Reconnect the electrical connector.
  - w. Fill the pump and test the valve for proper operation and leaks.
- 4. PG30 Relief Valve**  
(Refer to figure 6-12)
- a. Drain the pump.
  - b. Disconnect the indicator light switch.
  - c. Disconnect the line to the sensing valve.
  - d. Remove the 7/16-14UNC X2 inch long sensing valve mounting cap screw.
  - e. Remove the four 7/16-14UNC X 1-3/4 inch long cap screws retaining the relief valve assembly to the atmosphere dump.
  - f. Remove the four 7/16-14UNC X 1-1/2 inch long relief valve mounting cap screws to remove the relief valve from the pump body.
  - g. Remove the relief valve assembly.
  - h. Remove the four 7/16-14UNC X 1-3/4 inch long cap screws retaining the relief valve cover to the relief valve body.
  - i. Remove the indicator light switch assembly.
  - j. Apply a small amount of pressure to the relief valve spring, and remove the spring retaining ring and washer. Carefully release the pressure held on the spring and then remove the spring.
  - k. Remove the relief valve cover.
  - l. Remove the piston-retaining ring.
  - m. Remove the relief valve from the opposite end, sliding the relief valve stem out of the piston.
  - n. Reaching through the center hole of the piston, gently pull the piston from the indicator switch end of the relief valve body.
  - o. Before assembling and installing the valve, clean and inspect all components of the relief valve assembly.
  - p. Clean all sealing gasket surfaces and install new O-rings and gaskets.
  - q. Install the relief valve into the relief valve body.
  - r. Slide the piston into the relief valve body while at the same time sliding the piston onto the relief valve stem. Then, install the piston-retaining ring.
  - s. Install the new gasket, and then install the cover onto the relief valve body.
  - t. Install two 7/16-14UNC X 1-3/4 inch long cap screws finger-tight (to keep the relief valve cover aligned with the valve body).
  - u. Install the valve spring over the relief valve stem. Then, apply pressure to the valve spring to compress the spring.
  - v. Install the spring washer and the retaining ring.
  - w. Remove the two 7/16-14UNC X 1-3/4 inch long cap screws installed to keep the relief valve cover aligned with the valve body. Place the indicator switch bracket into position on the relief valve cover. Apply Loctite 242 to the four cap screws, install, and tighten to 53 ft-lb (72 Nm).
  - x. Apply Loctite 242 to the four 7/16 x 1-1/2 inch long cap screws and install the new gasket and the relief valve to the pump surface.

- y. Apply Loctite 242 to the four 7/16-14UNC X 1-1/2 inch long cap screws and install the new gasket and relief valve assembly to the atmosphere dump. Tighten to 53 ft-lb (72 Nm).
- z. Apply Loctite 242 to the 7/16-14UNC X2 inch long cap screw, install the sensing valve and tighten. Make sure the arrow on the sensing valve points upward.
- aa. Assemble indicator light switch and the switch strap and securely tighten the two screws.
- bb. Install the switch strap and light switch assembly in the switch bracket. Attach flasher assembly to bracket. Leave the two screws attaching the switch strap to the switch bracket slightly loose to allow the switch to move in and out for adjustment.
- cc. Connect the panel mounted indicator light or a suitable test light to the switch terminals. With the light switch plunger not in contact with the end of the poppet, the light should be lit.
- dd. With the pump not running and the relief valve fully closed, push the light switch in until the switch plunger makes contact with the end of the poppet and the light goes out. The switch is now in the proper position. Tighten the screws holding the switch strap to the bracket.
- ee. Connect the line to the sensing valve.
- ff. Fill the pump and test the valve for proper operation and leaks.

## 5. Sensing Valve

(Refer to figure 6-13)

- a. Disconnect the following lines at the sensing valve:
  - Pilot valve discharge line
  - QG relief valve line
  - PG relief valve line
  - Sensing valve pump suction line
  - Drain lines
- b. Remove the 7/16-14UNC X2 inch long sensing valve mounting cap screw.
- c. Remove the four 5/16-18UNC X 1 inch long cap screws attaching the control body to the rear of the spring housing. Remove the control body, being careful not to lose the sensing valve spring.
- d. Remove the control valve from the sensing valve body.
- e. Unscrew the sensing valve from the diaphragm, being careful not to damage the control valve. Remove the diaphragm.
- f. Before installing the sensing valve, clean all components.

### CAUTION

ALWAYS REMOVE THE SENSING VALVE SUCTION INLET SCREEN. CLEAN OR REPLACE AS NECESSARY. THE SCREEN IS LOCATED IN THE SUCTION SIDE OF THE PUMP. FAILURE TO DO SO MAY RENDER COMPONENTS INOPERATIVE.

- g. Install a new diaphragm on the diaphragm clamp. Apply Loctite to the threads on the control valve and install the control valve into the sensing valve body.
- h. Install the sensing valve spring into the valve body cover.





- i. Apply Loctite 242 to the four 5/16-18UNC X 1 inch long cap screws and attach the control body to the rear of the spring housing. Make sure that the sensing valve spring properly aligns with the diaphragm clamp.
  - j. Make sure the “up” arrow is aligned properly.
  - k. Apply Loctite 242 to the 7/16-14UNC X2 inch long sensing valve mounting cap screw. Tighten to 40 ft-lb (51 Nm).
  - l. Connect the lines.
  - m. Fill the pump and test the valve for proper operation and leaks.
- b. Install elbow into fitting and tighten so elbow outlet is positioned in the up position.
  - c. Install pressure switch in elbow outlet.
- 7. Reconnect drain tubing, discharge line, and electrical wiring.
  - 8. Fill the pump and test the valve for proper operation and leaks.

## H. TRV Service

(Refer to figure 6-11)

- 1. Disconnect electrical wiring, discharge line and drain tubing.
- 2. If TRV-L kit is installed.
  - a. Unscrew pressure switch from fitting.
  - b. Remove elbow.
  - c. Remove 1/8 MNPT x 1/8 FNPT fitting.
- 3. Unthread thermal relief valve from attachment flange.
- 4. Check inlet strainer for blockage. This should be accomplished once a year or more frequently in pumping water with impurities.
- 5. Apply coating of Loctite PST (or equal thread sealer) rethread thermal relief valve into attachment flange.
- 6. If TRV-L kit is installed, apply coating of Loctite PST to threads of fitting before assembly of parts.
  - a. Install 1/8 MNPT x 1/8 FNPT fitting into TRV body.

## I. Anode Replacement

(Refer to figure 6-17)

- 1. Consumable zinc anodes should be inspected at least every 12 months.
- 2. A minimum of two anodes per pump is recommended.
- 3. One anode should be installed on the suction side and the other on the discharge side of the pump.
- 4. To inspect the anodes, drain the pump.
- 5. Remove four 7/16-14UNC X 1-1/4 inch long cap screws and remove the anode and flange assembly.
- 6. Inspect the consumable zinc anode and replace when over 75% of zinc has been consumed (the original anode is 1.25 inches diameter by 2.125 inches long).
- 7. Clean all gasket surfaces.
- 8. Replace all gaskets, replace anode assembly if required, apply Loctite 242 to the four 7/16-14UNC X 1-1/4 inch long cap screws, install, and tighten to 40 ft-lb (54 Nm).
- 9. Fill the pump and test for leaks.



## J. Qtwo Transfer Valve

### 1. Drain the pump

**IMPORTANT:** The transfer valve is a timed device. It is therefore important during disassembly to note the location of the transfer bracket locating pin, the transfer drum stop pin, the transfer drum sleeve-locating pin, and the transfer drum stem key. It is not necessary to remove the transfer bracket locating pin, the transfer drum sleeve locating pin, or the transfer drum stop pin during disassembly.

2. Turn the adjustment handwheel clockwise until it stops. The transfer indicator should be at the top of the slotted guide in the cover plate.

3. Remove the two allen-head setscrews from the transfer indicator guide. Slide the transfer indicator guide (on an adjustment stem) towards the transfer valve.

4. Remove the stem drive gear lock pin. Slide the adjustment stem from the stem drive, the support, and the transfer indicator guide, being careful not to drop or damage the transfer indicator guide and transfer indicator.

5. Remove the four 7/16-14UNC X 1-1/4 inch long cap screws retaining the transfer bracket assembly to the pump body. Carefully remove the transfer bracket and the transfer valve drum.

6. Disassemble the valve.

- a. Remove the locating pin that secures the countershaft in place.
- b. Remove the countershaft from the countershaft gear.
- c. Remove the countershaft gear and the countershaft gear spring from the transfer bracket assembly.
- d. Remove the allen-head setscrew from the transfer drum gear. Slide the transfer drum gear from the drum

stem. Remove the woodruff key from the transfer drum stem.

- e. Separate the transfer bracket from the transfer drum by sliding it from the transfer drum stem.
- f. Slide the transfer drum from the transfer sleeve.

### 7. Assemble the Valve

a. Clean and inspect all sealing surfaces and the mating surfaces of the transfer valve drum and sleeve. Clean and inspect the transfer bracket bushings and bushing surface on the transfer valve stem and the transfer valve adjustment stem.

b. Install new O-ring seals on the transfer valve drum stem and the transfer valve bracket.

c. Slide the transfer drum into the transfer bracket, being careful not to damage the bearing surfaces. Then, rotate the transfer drum until the drum stop pin is in the correct position.

d. Install the woodruff key into the transfer drum stem. Install the transfer drum gear onto the transfer drum stem. Apply Loctite 242 to the allen-head set screw and install the transfer drum gear.

e. Assemble the countershaft gear spring in the countershaft gear, and position the assembly into place in the transfer bracket. Then, install the countershaft and the countershaft-locating pin to lock the countershaft in place.

### 8. Install the Transfer Valve

a. Align the transfer drum stop pin, the transfer bracket-locating pin, and the transfer drum sleeve locating pin into proper position.



- b. Install the transfer valve drum and bracket assembly into the pump body.
- c. Apply Loctite 242 to the four 7/16-14UNC X 1-1/4 inch long transfer bracket cap screws, and install and tighten to 53 ft-lb (72 Nm).
- d. Slide the adjustment stem through the cover plate, the transfer indicator guide, and the support and transfer bracket.
- e. Insert the stem drive gear into place in the transfer bracket, and then slide the adjustment stem through the stem drive gear.
- f. Insert the stem drive gear lock pin into place, locking the stem drive gear onto the adjustment stem.
- g. Apply Loctite 242 to the transfer indicator guide set screws and install. Do not tighten.
- h. Turn the adjustment handwheel counter clockwise until it stops. Make sure the transfer indicator is at the top of the slotted guide toward the transfer indicator, making certain that the transfer indicator engages the transfer indicator guide in the top groove. Then, tighten the inside setscrew in the transfer guide indicator.
- i. Rotate the adjustment handwheel from stop to stop. The transfer indicator should move freely from the top to the bottom of the slotted guide in the cover plate.
- j. Tighten the outside setscrew in the operation indicator guide, and recheck the movement of the transfer indicator.
- k. Fill the pump and test the valve for proper operation and leaks.

## K. Qtwo Check Valves (two-stage only)

(Refer to figure 6-4)

1. Drain the pump.

**NOTE:** there are two check valves (one on each side) in the suction side on the front of the Qtwo pump body. The following procedure is used for both check valves.

2. Remove the four 1/2-13UNC X 1-1/4 inch long cap screws from the check valve cover on the front side of the pump body. Note position of check valve for reassembly.
3. Remove the check valve.
4. Clean the gasket surfaces, and inspect the check valve pivots and pivot sockets.
5. Install the check valve.
6. Install the new gasket in the pump body.
7. Apply Loctite to the four cap screws and secure the check valve cover to the pump body with the cap screws, being careful to align the check valve pivot with the pivot socket in the check valve cover. Tighten to 53 ft-lb (75 Nm).
8. Fill the pump and test the valve for proper operation and leaks.



## L. Tank to Pump Check Valve

1. Drain the water tank and the pump.
2. Disconnect the control linkage at the Tank-to-Pump Valve.
3. Disconnect both ends of the flexible hose connecting the water tank to the Tank-to-Pump valve. Then, slide the flexible hose toward the water tank outlet or the Tank-to-Pump valve plumbing.

**NOTE:** If the tank-to-pump valve is air-operated, drain the vehicle's air system and disconnect the supply and the return line on the valve actuator, but do not remove the actuator from the valve. Also, the tank-to-pump valve may be connected to the pump body by cap screws or studs with nuts. If studs are used, it may be necessary to remove some or all of the studs to remove the valve. If so, remove only the studs necessary to remove the valve, as any studs left will assist in realigning the valve during installation.

4. Remove the eight 7/16-14UNC X 1-1/2 inch long cap screws retaining the tank-to-pump valve to the pump body.
5. Remove the tank-to-pump valve and associated plumbing.

**NOTE:** The back flow valve is a flat butterfly plate with two pivots attached at the top. These pivots fit into two open pivot sockets in the pump body. When the gasket is removed, the back flow valve may fall out.

6. Remove the old gasket from the pump body.
7. Remove the back flow valve.
8. To install the back flow valve, first clean all of the gasket surfaces on the pump body and the tank-to-pump flange.
9. Install the back flow valve. Using two fingers, hold the pivots in the pivot sockets and check the valve for freedom of movement.

10. Install a new gasket.
11. Apply Loctite 242 to the eight 7/16-14UNC X 1-1/2 inch long cap screws and attach the tank-to-pump valve to the pump body. Tighten to 53 ft-lb (72 Nm).
12. Slide the flexible connection hose so it is evenly spaced and secured on the water tank outlet and the tank-to-pump valve plumbing.
13. Attach the tank-to-pump valve controls and linkage.
14. Fill the pump and test the valve for proper operation and leaks.

## M. Suction Extension and Suction Tube

1. Place apparatus out of service.
2. Open and drain pump body.
3. Remove twelve 7/16-14UNC X 1-1/4 inch long cap screws from suction tube flange.
4. Clean suction tube and all components.
5. Remove fourteen 1/2-13UNC X 1-1/4 inch long cap screws from the suction tube extension.
6. Clean the suction tube extension and all components.
7. Clean seating surfaces of pump body, housing, suction tube extension and suction tube.
8. Place a new gasket on the seating surface of the pump body. Apply a light coat of grease to the gasket to hold it in place.
9. Reinstall suction tube extension, insert fourteen 1/2-13UNC X 1-1/4 inch cap long screws, torque to 65 ft-lb (88N-m).

10. Place a new gasket on the seating surface of the suction tube extension. Apply a light coat of grease to the gasket to hold it in place.
11. Reinstall the suction tube, insert twelve 7/16-14UNC X 1-1/4 inch long cap screws. Using a criss-cross pattern, torque to 40 ft-lb (54 N-m).
12. Fill the pump and test for leaks.

- e. Disconnect the pump gearbox cooling lines.
- f. Disconnect the electrical switches and the airlines.
- g. Remove the fire pump gearbox. See paragraph B.1, this section.
- h. Secure the pump gearbox into a holding fixture.
- i. Remove and disassemble the intermediate shaft assembly (refer to figure 5-7).

## N. Gearbox Disassembly and Assembly

### G-Series

#### 1. Removal and Disassembly

- a. Park the vehicle on a level surface. Shut down the engine. Set the parking brake and chock the front and rear tires.
- b. Drain the water from the pump.
- c. Drain the gearbox lubricant.
- d. Disconnect the drive shafts from the gearbox.

- 1) Remove the 7/16-14UNC X 1 inch long cap screw holding the intermediate shaft washer, remove the washer.
- 2) Carefully press the intermediate gear shaft out of the gearbox housing from the rear to the front.
- 3) Reach into the top of the gearbox housing and remove the intermediate gear spacer and the intermediate gear.

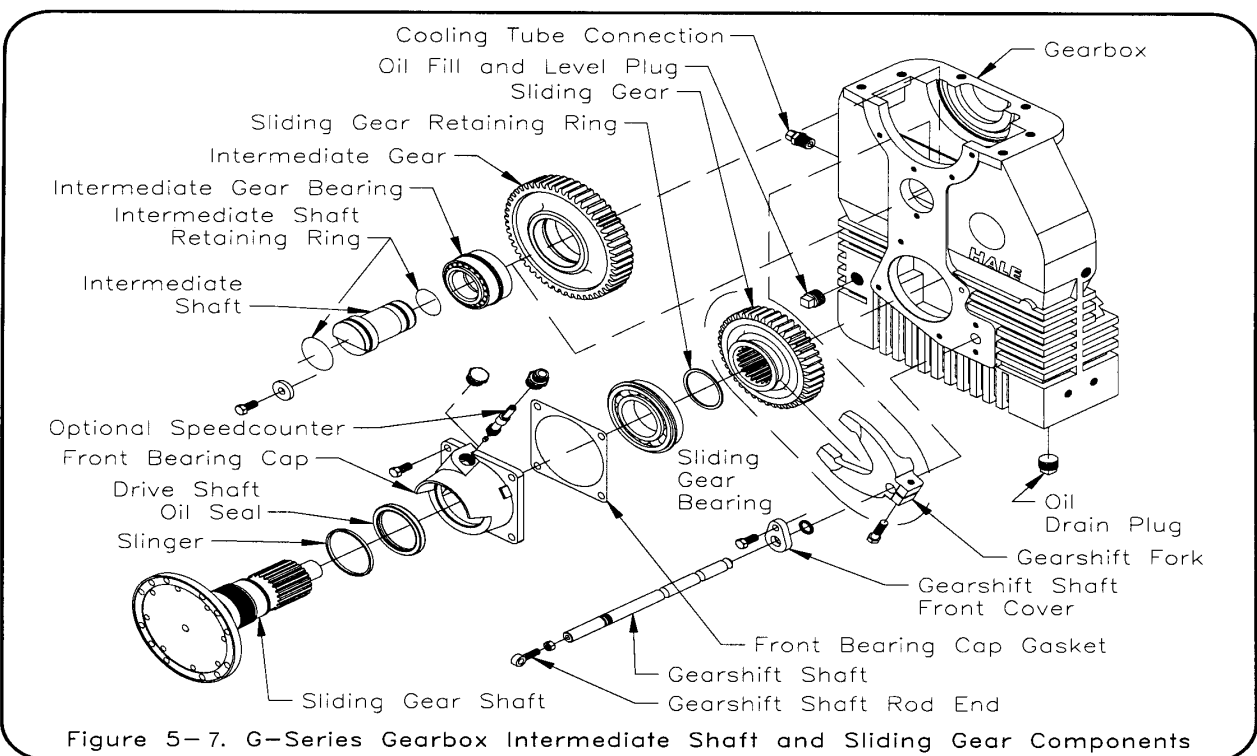

- 4) Remove the intermediate gear bearing from the intermediate gear.
  - 5) Remove the two different size intermediate shaft seal rings from the intermediate gear shaft.
  - 6) Clean and inspect each component of the intermediate shaft assembly. Inspect bearings for wear, pitting, and damage. Inspect the gear tooth surface for wear damage and pitting, replace all components that are worn, damaged, or pitted.
- j. Remove and disassemble the tail shaft assembly (refer to figure 5-8).

**NOTE:** If the tail shaft and sliding gear shaft require service it is not necessary to remove the gearbox from the apparatus.

**NOTE:** If only the tail shaft assembly needs to be removed, set the gearshift mechanism to engage the sliding gear with the sliding gear shaft (pump position).

- 1) Loosen the 3/8-16UNC inch hex nut locking the gearshift rod end to the gear shaft. Remove the gearshift rod end with the hex nut.
- 2) Remove the 1/2-20 UNF X 1/2 inch long nylon locking set screw, gearshift lock spring and gearshift ball from the gearshift shaft cap.
- 3) Remove two 5/16-18 hex nuts and two 5/16-18UNC X 1 inch long cap screws and remove the cylinder cover.
- 4) Remove the outer retaining ring locking the cylinder piston to the gearshift shaft
- 5) Remove the cylinder piston, then remove the inner retaining ring.
- 6) Remove two 7/16-14UNC X 1 inch long nylon locking cap screws and remove the shifting cylinder.

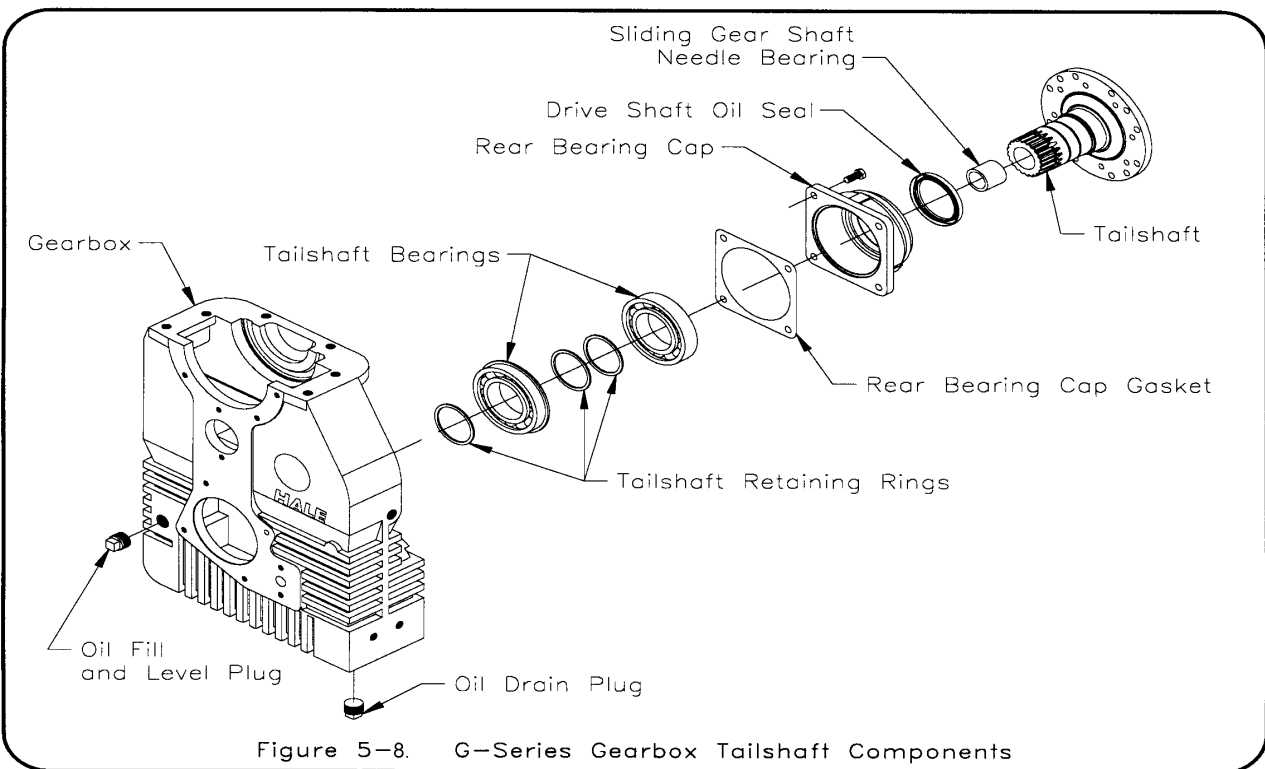

Figure 5-8. G-Series Gearbox Tailshaft Components





**NOTE:** The gearshift fork cannot be removed from the sliding gear shaft until the sliding gear is removed.

- 7) Remove four 7/16-14UNC X 1 inch long nylon locking cap screws securing the rear bearing cap to the gearbox housing.
- 8) Remove the tail shaft assembly from the gearbox housing.
- 9) Remove the inner tail shaft bearing retaining ring from the tail shaft.
- 10) Remove the inner tail shaft bearing from the shaft and rear bearing cap.
- 11) Remove the inner tail shaft outer retaining ring from the tail shaft.
- 12) Remove the outer tail shaft bearing retaining ring.
- 13) Remove the tail shaft from the rear bearing cap.
- 14) Remove the outer tail shaft bearing from the rear bearing cap.
- 15) Remove the drive shaft oil seal from the rear bearing cap.
- 16) Clean and inspect each component of the tail shaft assembly. Inspect bearings for wear, pitting, and damage. Inspect gear tooth surface for wear, damage, and pitting. Replace all components that are worn, damaged, or pitted.

- k. Remove and disassemble the sliding gear assembly (refer to figure 5-7).

**NOTE:** If the tail shaft and sliding gear shaft require service it is not necessary to remove the gearbox from the apparatus.

**NOTE:** If only the sliding gear assembly needs to be removed, set the gearshift mechanism to engage the sliding gear with the tail shaft (road position).

- 1) Remove four 7/16-14UNC X 1 inch long nylon locking cap screws securing the front bearing cap to the gearbox housing.
- 2) Remove the sliding gear assembly from the gearbox housing.
- 3) Remove the sliding gear bearing retaining ring from the sliding gear shaft.
- 4) Remove the sliding gear bearing from the sliding gear shaft and front bearing cap.
- 5) Remove the sliding gear shaft from the front bearing cap.
- 6) Remove the drive shaft oil seal from the front bearing cap.
- 7) Reaching through the top of the gearbox housing, carefully remove the sliding gear.

**NOTE:** Make a note of the location of the gearshift fork in relation to the gearshift shaft before removing.

- 8) Loosen the 7/16-14UNC X 1-3/4 inch long cap screw attaching the gearshift fork to the gearshift shaft, and then pull the shaft from out of the gearbox housing.
- 9) Reaching through the top of the gearbox housing, carefully remove the gearshift fork with the cap screw attached.
- 10) Clean and inspect each component of the sliding gear assembly, inspect bearing for wear, pitting, and damage, inspect gear tooth surface for wear, damage, and pitting, replace all components that are worn, damaged, or pitted.





- l. Inspect the Cooling Tube for Damage and Leaks.
- m. Remove and disassemble the remainder of the gearshift shaft cap.
  - 1) Remove two 7/16-14UNC cap screws, then remove the gearshift shaft cap. See figure 6-5.
  - 2) Remove the gearshift switches from the gearshift shaft cap..
  - 3) Clean and inspect each component of the gearshift shaft cap assembly. Replace all components that are worn, damaged or pitted.
- 2) Apply Loctite 242 to the 7/16-14UNC X 1-3/4 inch long cap screw that attaches the gearshift fork onto the gearshift shaft. Tighten to 25 ft-lb (34 Nm).
- 3) Reaching through the top of the gearbox housing, place the sliding gear into the shift fork. Make sure the shift fork groove on the sliding gear is oriented towards the front of the gearbox.
- 4) Install a new drive shaft oil seal in the front bearing cap.
- 5) Using a brass drift or a bearing installation tool, install the sliding gear bearing allowing the retaining ring to contact the surface of the front bearing cap.

## 2. Assembly and Installation

- a. Assemble and install the gearshift cap.
  - 1) Install new switch seal ring on the gearshift switches. Thread gearshift switch into the gear shift shaft cap.
  - 2) Install a new gearshift cap gasket on the gearbox housing.
  - 3) Apply Loctite 242 to the two 7/16-14UNC cap screws and install the gearshift shaft cap to the gearbox housing. Secure cap with two 7/16-14UNC cap screws.
- b. Assemble and install the sliding gear assembly.
  - 1) Reaching through the top of the gearbox housing, hold the gearshift fork in place, slide the gearshift shaft through the opening in the front of the gearbox housing, through the gearshift fork. Insure fork is in the proper position.
  - 6) Install the slinger on the sliding gear shaft.
  - 7) Insert the sliding gear shaft into the front bearing cap by sliding it from the front to the rear. Be sure to be careful when sliding shaft through the drive shaft oil seal and bearing.
  - 8) Install bearing retaining ring.
  - 9) Install a new front bearing cap gasket onto the front bearing cap (hold gasket in place using a general purpose grease).
  - 10) Apply Loctite 242 to the four 7/16-14UNC X 1 inch long cap screws. Then install the sliding gear shaft and front bearing cap and tighten to 40 ft-lb (54 Nm).
  - 11) The sliding gear shaft will mesh with the sliding gear. Insure the gearshift fork is in its proper position.



c. Assemble and install the tail shaft assembly.

- 1) Using a brass drift or a bearing installation tool, install the outer tail shaft bearing in the rear bearing cap.
- 2) Install a new drive shaft oil seal in the rear bearing cap.
- 3) Insert the tail shaft into the rear bearing housing, be careful when sliding the shaft through the drive shaft oil seal and tail shaft outer bearing.
- 4) Install the tail shaft retaining ring to secure the outer tail shaft bearing in its proper position on the tail shaft.
- 5) Install the inner tail shaft retaining ring.
- 6) Using a brass drift or a bearing installation tool, install the inner tail shaft bearing from the outside until the retaining ring contacts the surface of the tail shaft housing.
- 7) Install the tail shaft inner bearing inner retaining ring.
- 8) Install the sliding gear shaft needle bearing in the front end of the tail shaft.
- 9) Apply a light coating of grease and apply new gasket to tail shaft housing.
- 10) Install the tail shaft and rear bearing cap. Be careful when sliding the tail shaft with the sliding gear needle bearing will slide over the male end of the sliding gear shaft.

- 11) Apply Loctite 242 to the four 7/16-14UNC X 1 inch long cap screws. Then install the rear bearing cap and tighten the cap screw to 40 ft-lb (54 Nm).
- 12) Install a new shifting cylinder gasket.
- 13) Install a new gearshift shaft seal ring in the shifting cylinder.
- 14) Install the shifting cylinder by sliding it over the gearshift shaft until it contacts the gearbox housing. Apply Loctite 242 to the two 7/16-14UNC X 1 inch long nylon locking cap screws and tighten.

**NOTE:** Install piston retaining rings with flat side (square corners) facing away from piston.

- 15) Install the inner piston-retaining ring on the gearshift.
- 16) Install a new piston inner seal ring on the gearshift shaft.
- 17) Install a new piston outer seal ring on the cylinder piston.
- 18) Install the cylinder piston on the gearshift with the flat side of the piston facing the interior of the cylinder.
- 19) Install the outer piston-retaining ring on the gearshift shaft.
- 20) Install a new gearshift shaft seal on the cylinder cover.
- 21) Install cylinder cover by sliding over the gearshift shaft. Apply Loctite 242 to the two 5/16-18UNC X 1 inch long hex head screws and two 5/16-18UNC studs and tighten.

- 22) Install the gearshift rod end on the end of the gearshift shaft. Tighten the 3/8-16UNC locking hex nut.
- d. Assemble and install the intermediate shaft assembly.
  - 1) Press a new intermediate gear bearing into the intermediate gear.
  - 2) Install new intermediate shaft seal rings on the ends of the intermediate shaft.
  - 3) Reaching through the top of the gearbox place the intermediate gear in position towards the front of gearbox housing.
  - 4) On the XG gearbox, hold the intermediate gear spacer in position towards the rear of the gearbox housing. Install the intermediate shaft (front cutout facing down) through the front opening in the gearbox housing.
  - 5) Press the intermediate shaft through the intermediate gear and the intermediate gear spacer until the cut out on the front of the shaft is flush with the surface of the gearbox housing.
  - 6) Apply Loctite to the 7/16-14UNC X 1 inch long cap screw, install the intermediate shaft washer and tighten cap screw.
  - 7) Rotate the sliding gear shaft and manually shift the gearshift shaft to check for proper operation.
  - 8) Using a lifting device remove the gearbox from the holding fixture.
  - 9) Install the fire pump gearbox; see paragraph B.2, this section.

## J-Series

(Refer to figure 6-6)

### 1. Removal and Disassembly

- a. Park the vehicle on a level surface. Shut down the engine. Set the parking brake and chock the front and rear tires.
- b. Drain the water from the pump.
- c. Drain the gearbox lubricant. Remove magnetic plug, level plug and sight gauge plug.
- d. Disconnect the drive shaft from the gearbox.
- e. Remove the fire pump gearbox. See paragraph B.1, this section.
- f. Secure the pump gearbox into a holding fixture.
- g. Remove and disassemble the idler shaft assembly (refer to figure 6-6).
  - 1) Remove the locknut and washer from the idler shaft.
  - 2) Carefully press the idler shaft out of the gearbox housing.
  - 3) Reach into the top of the gearbox housing and remove the idler gear.
  - 4) Remove the idler gear bearing from the gear.
  - 5) Remove the two different size idler shaft seal rings from the idler gear shaft.
  - 6) Clean and inspect each component of the idler shaft assembly. Inspect bearings for wear, pitting and damage. Inspect the gear tooth surface for wear, damage and



pitting, replace all components that are worn, damaged or pitted.

h. Remove and disassemble the input shaft assembly.

- 1) Remove the 1/2-13UNC X 1-1/4 inches long cap screw and washer.
- 2) Using an appropriate puller, remove the companion flange from the input shaft.
- 3) Remove the .375x1.563 long square key from the input shaft.
- 4) Remove the oil seal from the companion flange end of the drive shaft, then remove the bearing retaining ring.
- 5) Remove oil seal from other sides of gearbox and remove the bearing retainer ring.
- 6) Using proper press, carefully press input shaft from gearbox housing.
- 7) Remove bearings and .500 x 2.063 long square key from input shaft.
- 8) Note orientation of gear, then reach into top of gearbox housing and remove input gear from gearbox housing.
- 9) Using bearing puller, remove bearing from gearbox housing if necessary.

**2. Assembly and Installation**

a. Assemble and install the input shaft.

- 1) Obtain a new 309 bearing and install in non-drive side of gearbox housing.
- 2) Install new split ring in non-drive side of housing.

3) Place input gear into gearbox housing in proper orientation.

4) Install .500 x 2.063 long key in the input shaft. Holding input gear in place, start to insert input shaft. Make sure key in shaft aligns with slot in gear. Make sure shaft aligns with bearing.

5) Install a new spherical roller bearing over input shaft. Align the shaft and bearing with housing and carefully press bearing into place.

6) Install new split ring into gearbox housing.

7) Press new oil seals into both sides of gearbox housing.

8) Install .375 x 1.563 key on input shaft, then install companion flange.

9) Apply Loctite 242 to 1/2-13UNC X 1-1/2 inches long cap screws, then install washer and cap screw.

b. Assemble and install the intermediate shaft assembly.

1) Press new idler gear bearings into the idler gear.

2) Install new shaft seal rings on the ends of the intermediate shaft.

3) Reaching through the top of the gearbox, place the intermediate gear in position towards the front of the gearbox housing.

4) Press the idler shaft through the idler gear until the shaft is seated in the gearbox housing.

5) Apply Loctite to the idler shaft threads, install the idler shaft washer and locknut. Tighten lock nut.



- 6) Rotate the input gear shaft to check for proper operation.
- 7) Using a lifting device, remove the gearbox from the holding fixture.
- 8) Install the gearbox; see paragraph B.2 this section.

## O. Primers

### 1. ESP Priming Pump (Refer to figure 6-7)

The hale ESP primer is relatively maintenance free. If after testing of the priming system the primer fails to pull the required vacuum the primer vanes may be worn and require replacement.

The following procedures should be used to replace the primer vanes.

- a. Place apparatus out of service in accordance with departmental procedures.
- b. De-energize apparatus electrical system.

**NOTE:** Before beginning disassembly make note of the position and locations of components to ensure correct re-assembly.

- c. Tag and disconnect wires from battery connection, solenoid connection and ground connection point.
- d. Tag and disconnect hose from suction connection.
- e. Loosen nuts on studs or bolts that hold primer assembly to mounting pad. Remove primer to suitable work area.
- f. Remove the 3/8-16 UNC X2-1/2 inch long cap screw and remove the 3/8-16 UNC nut from stud. Carefully separate pump assembly from motor.

- g. Using a non-marring mallet carefully separate the pump head from the pump body.
- h. Remove the shaft and rotor assembly, and the vanes from the pump body.
- i. Remove the seal from the pump head assembly.
- j. Inspect all components for corrosion and abnormal wear. Clean all components. Obtain new components as necessary.
- k. Carefully press new seal into the pump head assembly.
- l. Insert rotor and shaft assembly into pump body assembly. Slide new vanes into the slots in the rotor. Rotate the rotor and shaft making sure the vanes move freely in the slots.
- m. If necessary install new pins into the pump head assembly. Align the pins with the holes in the pump body assembly and slide pump head over rotor shaft. Once head is seated against the pump body make sure the rotor assembly turns freely in the pump assembly.
- n. Install motor on pump assembly and secure in place using 3/8-16 UNC X2-1/2 inch long cap screw and 3/8-16 UNC nut on the stud. Tighten the nut and cap screw.
- o. Place primer assembly on the mounting point and tighten cap screws or nuts.
- p. Reconnect suction hose making sure the connection is tight.
- q. Reconnect ground wire, battery connection and solenoid connection.
- r. Energize apparatus electrical system.



- s. Tests operate the primer to ensure it is working correctly.
- t. Return apparatus to normal operation.

**2. SPV Priming Valve**  
(Refer to figure 6-8)

- a. Drain the pump.
- b. Disconnect the 3/4 inch (19 mm) vacuum hose connecting the priming valve to the primer. Remove two 7/16-14UNC nuts attaching the priming valve to the studs in the pump body or universal adapter if mounted.

**NOTE:** If the strainer and O-ring seal remains on the pump body, remove it carefully for cleaning and installation. If the valve strainer is removed as part of the priming valve, remove it from the body and set it aside. Use care as the valve strainer is easily damaged.

- c. Note the location of the drain hole in the diaphragm cover, and then remove the eight 5/16-18UNC X3/4 inch long cap screws securing the diaphragm cover to the valve body. Remove the diaphragm cover and the diaphragm.
- d. Hold pressure on the diaphragm washer to compress the valve spring, then remove the diaphragm washer retaining screw. Remove the diaphragm washer and valve spring. From the opposite side of the valve body, remove the valve.
- e. Clean all components of the priming valve and mating surfaces. Inspect the valve seat, and replace, if worn or damaged.
- f. Install the valve into the valve body from the pump side of the body.

- g. Install the valve spring and diaphragm washer onto the valve. Apply Loctite 242 to the diaphragm washer retaining screw, compress the valve spring with the diaphragm washer and install the valve.
- h. Align the diaphragm holes with the cap screw holes in the diaphragm cover. Apply Loctite 242 to the eight 5/16-18UNC X3/4 inch long cap screws and install the diaphragm cover and diaphragm valve body. Tighten to 17 ft-lb (23 Nm).
- i. Install the valve strainer and O-ring seal onto the pump side of the priming valve.
- j. Apply Loctite 242 on the two 7/16-14UNC priming valve-mounting nuts and install the priming valve into the pump body. Tighten to 40 ft-lb (54 Nm).
- k. Connect the vacuum hose to the primer.
- l. Fill the pump and test the valve for proper operation and leaks.

**3. PVG Priming Valve.**  
(Refer to figure 6-9)

- a. Drain the pump.
- b. Disconnect the 3/4 inch flexible hose to the ESP priming pump and the electrical connections.
- c. Remove two 7/16-14UNC X 1-1/4 inch cap screws retaining the PVG priming valve to the pump body.
- d. Remove the PVG priming valve and discard.
- e. Remove the old gasket from the pump body.



- f. Remove, clean and inspect the priming valve strainer, replace if required.
- g. Clean the pump body gasket surface.
- h. Reinstall the priming valve strainer.
- i. Install a new gasket.
- j. Apply Loctite 242 to the two 7/16-14UNC X 1-1/4 inch long cap screws and install a new PVG priming valve.
- k. Reinstall the 3/4 inch flexible hose from the ESP priming pump and reconnect the electrical connections.
- l. Fill the pump and test the valve for proper operation and leaks.

b. Service

- 1) If the valve leaks, it is probably due to the O-ring seal not pressing tightly enough against the seal. To ensure the pressure of the O-ring against the valve ball:

- a) Remove the valve cover.

**NOTE:** The valve is usually assembled with two or three gaskets. Do not remove too many gaskets. The valve should turn easily yet hold a vacuum and pressure. Never remove the last gasket.

- b) Remove one valve cover gasket.

- c) Reassemble and check for leaks.

- d) If leaks persist, repeat steps A through C.

- e) If valve still leaks, remove the cover and turn the O-ring around and put the new side against the ball. Reassemble and test.

- f) If this fails, install a new O-ring.

**NOTE:** If the valve has high usage and wear, it might be necessary to install a new ball, pivot or stem.

- g) If valve leaks up through the stem, install a new stem O-ring.

c. Disassembly and Assembly

To disassemble valve, refer to procedures below. When disassembled, clean and inspect all components for excessive wear and damage. Replace O-rings and gaskets. Reassemble, install and test for proper operation and leaks.

## P. Accessories

### 1. Valves (General Procedure for maintenance of valves).

a. Lubrication

- 1) On a Hale ball valve, using a brush, lubricate the face of the ball with waterproof grease once a week.
- 2) On a suction valve, squirt some oil in the space next to the rubber washer to lubricate the swivel balls. The remote control linkage connecting the valves should be lubricated monthly.
- 3) If a drain valve is installed on a discharge valve, insert an oil can tip in the open end of the discharge valve and allow some oil to run down the connecting pipe to the closed drain valve.
- 4) If the discharge valve has a built-in drain valve, oil the passageway that the drain valve piston slides in then move the piston back and fourth to lubricate the seal rings.



## 2. 40BD Series Valve Maintenance

(Refer to figures 6-19 and 6-20)

The Hale 40BD series valve requires a minimum amount of maintenance. Most maintenance can be performed with the valve in place on the apparatus. The only time the valve must be removed is when there is not access to the valve or the valve requires rebuilding.

- a. To remove the valve from the apparatus do the following:
  - 1) Place apparatus out of service in accordance with departmental procedures.
  - 2) Open all drains and release pressure from pump system.
  - 3) Tag and disconnect electrical wires from valve.
  - 4) Disconnect valve operator reach rods and remove panel interference.
  - 5) Disconnect drain lines from valve

**CAUTION**

VALVE BODY IS HEAVY. MAKE SURE THE VALVE BODY IS PROPERLY SUPPORTED BEFORE REMOVING FASTENING DEVICES.

- 6) Remove thread cap from T-bolt on V-clamps.
- 7) Remove jam nuts from clamps then loosen T-bolt nuts.
- 8) Slide the clamps towards the connectors to clear valve.
- 9) Slide valve body from between both connectors.
- 10) Take valve to suitable work area for disassembly and repair.

- b. To install the valve in the apparatus do the following:

- 1) Make sure the connector mating surfaces are clean and free from debris and dirt.
- 2) Make sure the V-clamps are on the connectors and there is clearance to allow insertion of the valve body between the connectors.
- 3) Apply a small amount of grease to the O-ring grooves on the valve body to hold the O-rings in place and install new O-rings in both grooves.
- 4) Making sure the O-rings do not get pinched slide the valve body between the connectors.
- 5) Once valve is in place and oriented slide the V-clamps into place over the valve body groove and connectors.
- 6) Tighten the T-bolt nut to 20 ft-lb (27 Nm) on each clamp. Install jam nuts then install thread caps.
- 7) Reconnect drain lines, operator reach rods and electrical connections.

- 8) Test apparatus and check valve for leaks.
- 9) Return apparatus to normal operation.

- c. To lubricate valve ball and seat do the following:

- 1) Place apparatus out of service in accordance with departmental procedures.
- 2) Open all drains and release pressure from pump system.



d. On valves with 5 inch NST discharge fittings

- 1) Remove cap from discharge connection
- 2) Reaching into discharge tube apply a coating of grease to the valve ball surface.
- 3) Making sure hands and fingers are clear manually operate valve through a couple of complete cycles to spread grease.
- 4) On valves mounted in line or tank suction valves do the following:
  - a) Gain access to the outlet side of valve.
  - b) Remove piping from discharge connection.
  - c) Remove thread cap from T-bolt on V-clamp.
  - d) Remove jam nut from clamp then loosen T-bolt nut.
  - e) Slide the clamp towards the connectors to clear valve then remove the connector and O-ring.
  - f) Apply a coat of grease to the valve ball.
  - g) Make sure fingers are clear of valve and manually operate valve through a few complete cycles.
  - h) Apply a light coat of grease to the O-ring groove and insert a new O-ring into groove.
  - i) Install discharge connector and secure in place by tightening T-bolt nuts to 20 ft-lb.
  - j) Install jam nut and thread cap.

k) Reconnect discharge piping.

- 5) Test operate apparatus and check for leaks.
- 6) Return apparatus to service.

**3. 40BD Valve Seat Replacement**

- a. Place apparatus out of service in accordance with departmental procedures.
- b. Open all drains and release pressure from pump system.
- c. Gain access to the outlet side of valve.
- d. Remove piping from discharge connection.
- e. Remove thread cap from T-bolt on V-clamp.
- f. Remove jam nut from clamp then loosen T-bolt nut.
- g. Slide the clamp towards the connectors to clear valve then remove the connector and O-ring.
- h. Carefully pry the seat housing out of the valve using the ridge provided.
- i. Push seat assembly out of housing.
- j. Clean and inspect all parts and mating surfaces.
- k. Install new valve seat seal on seat then push seat and seal assembly into housing.
- l. Apply a light coat of grease and install new seal in groove of seal housing.
- m. With the seat oriented towards the valve ball push seat and housing assembly into discharge side of valve body.



- n. Apply a light coat of grease to the O-ring groove and insert a new O-ring into groove.
- o. Install discharge connector and secure in place by tightening T-bolt nuts to 20 ft-lb (27 Nm).
- p. Install jam nut and thread cap.
- q. Reconnect discharge piping.
- r. Test operate apparatus and check for leaks.
- s. Return apparatus to service.

#### 4. Valve Stem Seal Replacement

- a. Place apparatus out of service in accordance with departmental procedures.
- b. Open all drains and release pressure from pump system.
- c. Gain access to the valve.
- d. Remove the 7/16-14 UNC X 1 inch long hex head cap screws that secure the top collar or bottom collar assembly to the pump body.
- e. Remove collar assembly from valve body.
- f. Remove old seal ring from stem. Make sure stem and seal ring groove are clean then install new seal ring on stem.
- g. Install new collar seal ring on collar assembly then install collar assembly in valve.
- h. Install the 7/16-14 UNC X 1 inch long hex head cap screws.
- i. Tighten screws to 40 ft-lb.

- j. Reattach any items that were removed from valve to gain access to the top and bottom collars.
- k. Test operate pump and check for leaks.
- l. Return apparatus to service.

#### 5. Drain Valve Repair Procedures

- a. Type HD Drain Valve:  
(Refer to figure 6-21)

If the type HD drain valve is leaking the seals must be replaced. Replace the seals using the following procedures:

- 1) Place apparatus out of service in accordance with department procedures.
- 2) Open all drain valves to make sure all pressure is relieved from the pump.
- 3) Gain access to inlet fitting on the valve and disconnect the hose or tube from the valve.
- 4) Holding stem with a pair of pliers if necessary and remove the knob from the valve stem.
- 5) Loosen or remove screws that hold valve body to the operator panel and remove valve assembly to suitable work area.
- 6) Remove the piston-retaining ring from the valve body.
- 7) Slide the piston assembly out of the valve body.
- 8) Remove the old seal rings from the valve piston.
- 9) Clean all parts and check for excessive wear or pitting.

- 10) Apply a light coat of general-purpose grease to the new seal rings and install in grooves on valve piston.
  - 11) Slide piston and seal ring assembly into the valve body being careful that the seal rings do not bind or get cut.
  - 12) Install piston-retaining ring into groove in valve body.
  - 13) Make sure the piston moves freely back and forth in the valve body.
  - 14) Install valve assembly into operator panel and tighten mounting screws.
  - 15) Screw operating knob onto valve stem.
  - 16) Attach hose or tubing to inlet fitting of the drain valve.
  - 17) Test operate apparatus and check drain valve for leaks.
  - 18) Return apparatus to normal operation.
- b. Type DV5 Drain Valve:  
(Refer to figure 6-22)

If the type DV5 drain valve is leaking the seals must be replaced. Replace the seals using the following procedures:

- 1) Place apparatus out of service in accordance with department procedures.
- 2) Open all drain valves to make sure all pressure is relieved from the pump.
- 3) Gain access to inlet fittings on the valve and disconnect the hoses or tubes from the valve.
- 4) Holding stem with a pair of pliers, if necessary, and remove the knob from the valve stem
- 5) Loosen or remove screws that hold valve body to the operator panel and remove valve assembly to suitable work area.
- 6) Remove the piston stop plate from the valve body.
- 7) Slide the piston assembly out of the valve body.
- 8) Remove the old seal ring from the valve piston. Also remove the seal ring that is cemented into the valve body.
- 9) Clean all parts and check for excessive wear or pitting.
- 10) Apply a light coat of general-purpose grease to the new seal ring and install in groove on valve piston
- 11) Apply a light coating of 3M EC847 (or equal) adhesive to the seal ring groove in the valve body and install the seal ring into the groove. Make sure the adhesive is dry before continuing installation.
- 12) Slide piston and seal ring assembly into the valve body being careful that the seal rings do not bind or get cut.
- 13) Install piston stop plate on valve body.
- 14) Make sure the piston moves freely back and forth in the valve body.
- 15) Install valve assembly into operator panel and tighten mounting screws.
- 16) Screw operating knob onto valve stem.



- 17) Attach hoses or tubing to inlet fittings of the drain valve.
  - 18) Test operate apparatus and check drain valve for leaks.
  - 19) Return apparatus to normal operation.
- c. Type DV7 Drain Valve:  
(Refer to figure 6-23)
- If the type DV7 drain valve is leaking the seals must be replaced. Replace the seals using the following procedures:
- 1) Place apparatus out of service in accordance with department procedures.
  - 2) Open all drain valves to make sure all pressure is relieved from the pump.
  - 3) Gain access to the backside of the valve body where the grease fitting is located. Remove any tubing or hoses that interfere with valve disassembly. Remove the retaining ring from the valve stem.
  - 4) Unscrew the valve stem completely from the valve body.
  - 5) Remove the retaining ring that holds the seat and seat retaining washer on the valve stem.
  - 6) Remove the seat retaining washer from the stem with the thrust washers.
  - 7) Remove the seat from the seat retaining washer.
  - 8) Remove the knob from the stem by loosening the set screw in the knob.
  - 9) Clean all parts and check for excessive wear or pitting. Check to make sure the sealing surfaces of the inlet fittings are clean and not pitted.
  - 10) Install a new seat in the seat retaining washer.
  - 11) Install a thrust washer on the stem then install the seat retaining washer and the other thrust washer. Secure these parts to the stem using the retaining ring.
  - 12) Install the operating knob on the stem and secure in place with the setscrew.
  - 13) Carefully thread the stem assembly into the valve body.
  - 14) Lock the stem assembly in the body using the retaining ring.
  - 15) Attach hoses or tubing to inlet fittings of the drain valve.
  - 16) Test operate apparatus and check drain valve for leaks.
  - 17) Return apparatus to normal operation.



**PARTS LIST HALE QPAK SERIES PUMPS  
FIGURE 6-1**

ITEM NO.	PART NO.	QTY.	DESCRIPTION
1	001-0920-00-0	1	Body - Center Pump
	001-0920-10-0	1	Body - Center Pump (Special Machining)
2	001-1920-01-0	1	Body - Left Side Pump
	001-1920-11-0	1	Body - Left Side Pump (Special Machining)
3	001-1920-02-0	1	Body - Right Side Pump
	001-1920-12-0	1	Body - Right Side Pump (Special Machining)
4	018-2016-02-0	34	Screw - 1/2 - 13 UNC X 1-3/4 in. Lg.
5	046-1670-00-0	1	Gasket - Left Side Pump Body
6	046-1680-00-0	1	Gasket - Right Side Pump Body
7	217-0201-00-0	4	Plug - 1/4 NPT Black MI
8	217-0301-00-0	2	Plug - 3/8 NPT Black MI
9	217-0401-00-0	2	Plug - 1/2 NPT Black MI
10	217-0501-00-0	2	Plug - 3/4 NPT Black MI
11	008-0010-00-0	2	Cap - 4-1/2 in. Suction Tube
	008-0020-00-0	2	Cap - 5 in. Suction Tube
	008-0030-00-0	2	Cap - 6 in. Suction Tube
12	097-0030-00-0	2	Washer - 4-1/2 in. Suction Tube Cap
	097-0040-00-0	2	Washer - 5 in. Suction Tube Cap
	097-0050-00-0	2	Washer - 6 in. Suction Tube Cap
13	010-0010-00-0	2	Strainer - 4-1/2 in. Suction Tube
	010-0020-00-0	2	Strainer - 5 in. Suction Tube
	010-0030-00-0	2	Strainer - 6 in. Suction Tube
14	018-1812-12-0	30	Screw - 7/16 - 14 UNC X1-1/4 in. Lg. Zinc Pl. Stl. Cap
15	007-0030-06-0	2	Tube - 4 in. Lg. 6 in. Suction
	007-0010-00-0	2	Tube - 6 in. in. Lg. 4-1/2 in. Suction
	007-0020-00-0	2	Tube - 6 in. Lg. 5 in. Suction
	007-0030-00-0	2	Tube - 6 in. Lg. 6 in. Suction
	007-0030-10-0	2	Tube - 7 in. Lg. 6 in. Suction
	007-0110-00-0	2	Tube - 9 in. Lg. 4-1/2 in. Suction
	007-0120-00-0	2	Tube - 9 in. Lg. 5 in. Suction
	007-0130-00-0	2	Tube - 9 in. Lg. 6 in. Suction
16	046-0040-00-0	2	Gasket - Suction Tube
17	005-0010-00-0	1	Plate - Priming Valve
18	040-2260-00-0	1	Seal Ring - Priming Valve Plate
19	010-0040-00-0	1	Strainer - Priming Valve
20	217-3001-00-0		Plug - Relief Valve (When Pump is furnished without Relief Valve)
21	040-2420-00-0	1	Seal Ring - Relief Valve Plug
22	046-0080-00-0	1	Gasket - Relief Valve Plug
23	046-0060-00-0	1	Gasket - Tank Suction Connection Flange
24	064-5070-01-0	1	Pin - Cotter (5/32 x 2 in. Lg.)
25	110-7040-00-0	1	Nut - Impeller
26	016-1060-00-0	1	Impeller
27	321-0440-00-0	2	Ring - Impeller Clearance



**PARTS LIST HALE QPAK SERIES PUMPS  
FIGURE 6-1 (CONT'D)**

ITEM NO.	PART NO.	QTY.	DESCRIPTION
28	296-5210-05-0	1	Seal - Mechanical
29	040-4490-00-0	1	Seal Ring - Head
30	046-1640-00-0	1	Gasket - Pump Body
31	017-0110-00-0	1	Key - Impeller
<b>G-SERIES IMPELLER ASSY</b>			
32	018-1812-07-0	20	Screw - 7/16-14 UNC X 1-1/4 in. Lg. Zinc Pl. Stl. 360° Nylon Locking Cap
33	046-6020-00-0	1	Gasket - Rear Bearing Housing
34	018-2412-07-0	1	Screw - 5/8-11 UNC X 1-1/4 in. Lg. Zinc Pl. Stl. 360° Nylon Locking Cap
35	097-0830-01-0	1	Washer - Rear Bearing
36	250-0409-00-0	1	Bearing - Pump Shaft Rear
37	031-0920-00-0	1	Gear - Pump Shaft (18 Teeth) (QPAK-23L, QPAK-28X Pumps)
	031-0930-00-0	1	Gear - Pump Shaft (20 Teeth) (QPAK-21L, QPAK-25X Pumps)
	031-0940-00-0	1	Gear - Pump Shaft (22 Teeth) (QPAK-19L, QPAK-23X Pumps)
	031-0950-00-0	1	Gear - Pump Shaft (24 Teeth) (QPAK-17L, QPAK-21X Pumps)
	031-0960-00-0	1	Gear - Pump Shaft (26 Teeth) (QPAK-15L, QPAK-19X Pumps)
38	017-0300-00-0	1	Key - Pump Shaft Gear
39	037-5140-00-0	1	Shaft - Pump
40	250-0211-20-0	2	Bearing - Pump Shaft
41	048-0150-00-0	1	Shim - Bearing
42	296-2090-00-0	1	Seal - Rear Bearing Housing Oil
43	077-2120-01-0	1	Ring - Pump Shaft Retaining
44	062-0770-00-0	1	Housing - Rear Bearing (QPAK-23L, QPAK-15L, QPAK-19X and QPAK-28X Pumps)
	062-0770-01-0	1	Housing - Rear Bearing (QPAK-21L, QPAK-17L, QPAK-25X and QPAK-21X Pumps)
	062-0770-02-0	1	Housing - Rear Bearing (QPAK-19L and QPAK-23X Pumps)
<b>J-SERIES IMPELLER ASSY</b>			
45	018-1812-07-0	12	Screw - 7/16-14 UNC X 1-1/4 in. Lg. Zinc Pl. Stl. 360° Nylon Locking Cap
46	018-2012-02-0	6	Screw - 1/2-13UNC X 1-1/4 in.Lg. Zinc Pl. Stl. Cap





---

**PARTS LIST HALE QPAK SERIES PUMPS  
FIGURE 6-1 (CONT'D)**

<b>ITEM NO.</b>	<b>PART NO.</b>	<b>QTY.</b>	<b>DESCRIPTION</b>
47	018-2620-02-0	1	Screw - 3/4-10 UNC X 2 in.Lg.
48	097-2160-00-0	1	Washer - Roller Bearing
49	250-8210-00-0	1	Bearing - Spherical Roller
50	159-1600-04-0	2	Spacer
51	031-1550-00-0	1	Gear - Pump Shaft (21 Teeth) (QPAK-25J Pump)
	031-1560-00-0	1	Gear - Pump Shaft (23 Teeth) (QPAK-23J Pump)
	031-1570-00-0	1	Gear - Pump Shaft (26 Teeth) (QPAK-21J Pump)
	031-1580-00-0	1	Gear - Pump Shaft (30 Teeth) (QPAK-18J Pump)
	031-1590-00-0	1	Gear - Pump Shaft (33 Teeth) (QPAK-16J Pump)
52	017-0650-02-0	1	Key - Pump Shaft Gear
53	077-9170-01-0	1	Ring - Split
54	250-8150-00-0	1	Bearing - Cylindrical Roller
55	296-2790-00-0	1	Seal - Pump Shaft
56	040-2360-00-0	1	O-Ring - Pump Head
57	037-2260-00-0	1	Shaft - Pump
58	062-0820-00-0	1	Head - Pump

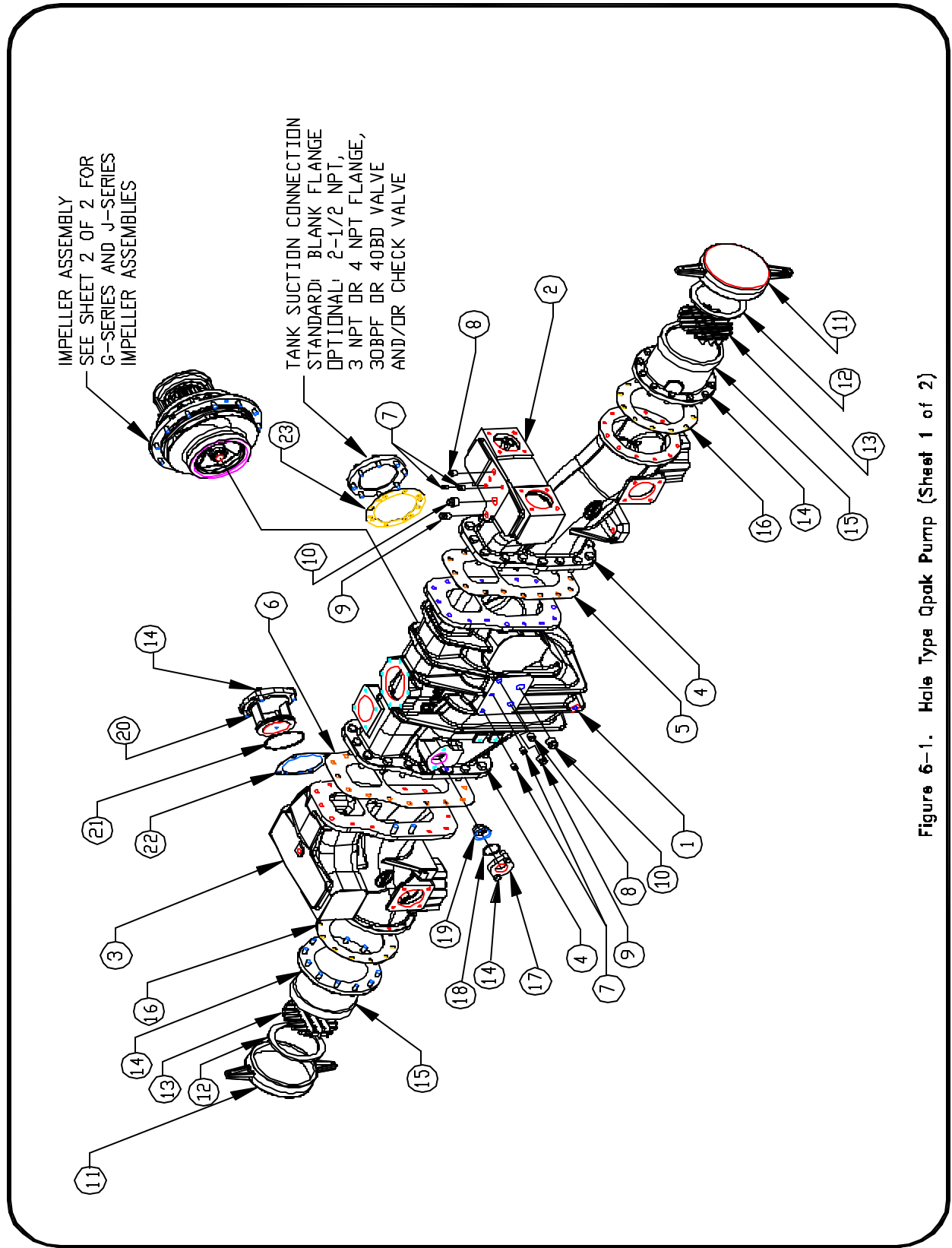

Figure 6-1. Hale Type Qpak Pump (Sheet 1 of 2)

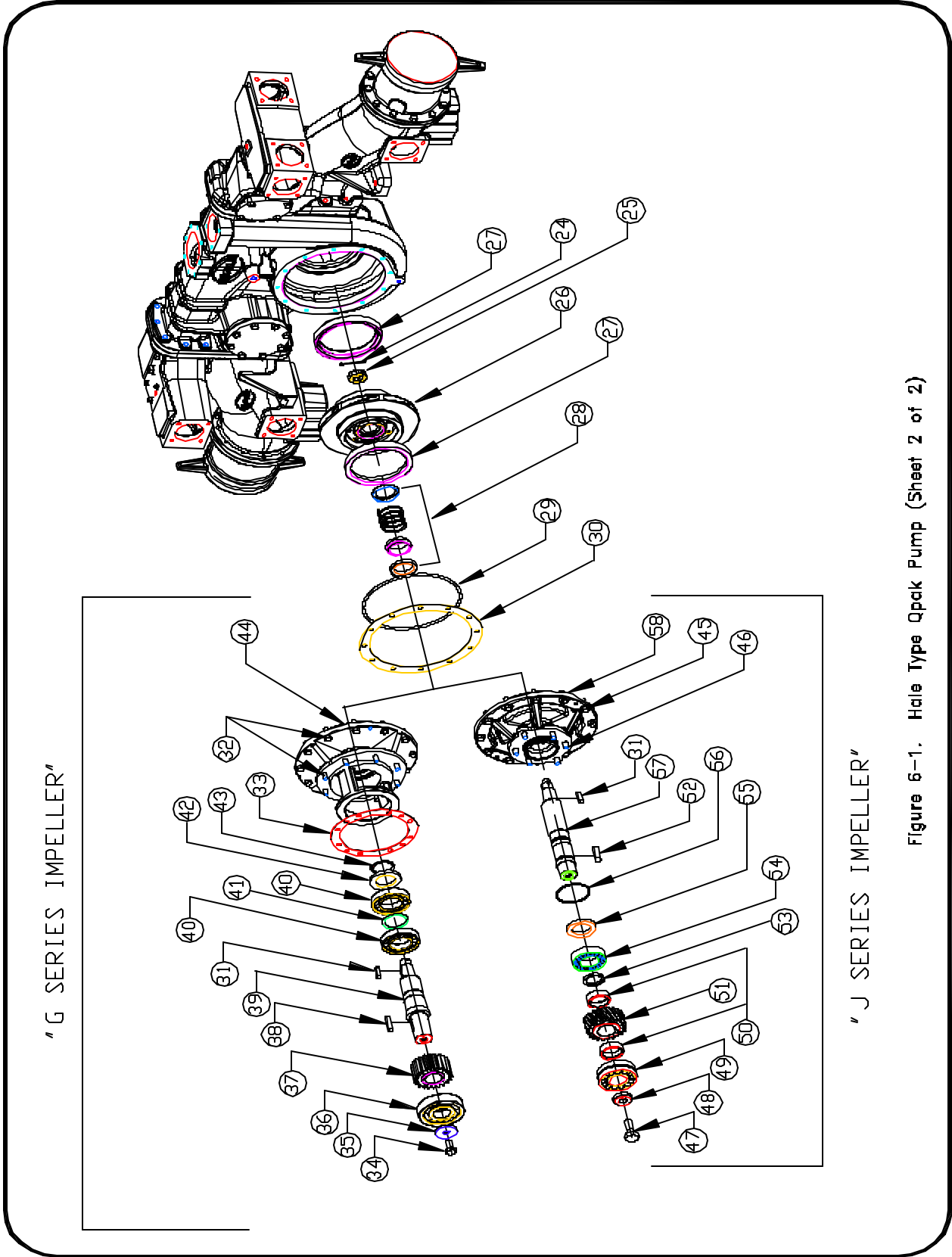

Figure 6-1. Hale Type Qpak Pump (Sheet 2 of 2)



**PARTS LIST HALE QFLO SERIES PUMPS  
FIGURE 6-2**

ITEM NO.	PART NO	QTY	DESCRIPTION
1	001-0890-00-0	1	Body-Pump
2	007-0010-00-0	2	Tube-4-1/2 Suction
	007-0010-00-0	2	Tube-5 Suction
	007-0020-00-0	2	Tube-6 Suction
3	008-0010-00-0	2	Cap-4-1/2 Suction Tube
	008-0020-00-0	2	Cap-5 Suction Tube
	008-0030-00-0	2	Cap-6 Suction Tube
4	010-0010-00-0	2	Strainer-4-1/2 Suction Tube
	010-0020-00-0	2	Strainer-5 Suction Tube
	010-0030-00-0	2	Strainer-6 Suction Tube
5	016-1050-00-0	1	Impeller
6	017-0110-00-0	1	Key-Impeller
7	017-0300-00-0	1	Key-Pump Shaft Gear
8	018-1812-02-0	78	Screw-7/16-14 x 1-1/4 Lg. Zinc Pl. Stl. Cap
	018-1812-02-0	4	Screw-7/16-14 x 1-1/4 Lg. Zinc Pl. Stl. Cap (Used when R.V. is omitted)
9	018-1812-07-0	20	Screw-7/16-14 x 1-1/4 Lg. Zinc Pl. Stl. 360° Nylon Locking Cap
10	018-2012-02-0	20	Screw-1/2-13 x 1-1/4 Lg. Zinc Pl. Stl. Cap
11	018-2012-07-0	8	Screw-1/2-13 x 1-1/4 Lg. Zinc Pl. Stl. 360° Nylon Locking Cap
12	018-2016-07-0	12	Screw-1/2-13 x 1-3/4 Lg. Zinc Pl. Stl. 360° Nylon Locking Cap
13	018-2412-07-0	1	Screw-5/8-11 x 1-1/4 Lg. Zinc Pl. Stl. 360° Nylon Locking Cap
14	031-0920-00-0	1	Gear-Pump Shaft (18 Teeth) (QFLO-23L, QFLO-28X Pumps)
	031-0930-00-0	1	Gear-Pump Shaft (20 Teeth) (QFLO-21L, QFLO-25X Pumps)
	031-0940-00-0	1	Gear-Pump Shaft (22 Teeth) (QFLO-19L, QFLO-23X Pumps)
	031-0950-00-0	1	Gear-Pump Shaft (24 Teeth) (QFLO-17L, QFLO-21X Pumps)
	031-0960-00-0	1	Gear-Pump Shaft (26 Teeth) (QFLO-15L, QFLO-19X Pumps)
15	037-5140-00-0	1	Shaft-Pump
◆◆ 16	040-4490-00-0	1	Seal Ring-Head
◆◆ 17	046-0030-00-0	2	Gasket-Suction Tube Extension
◆◆ 18	046-0040-00-0	2	Gasket-Suction Tube
◆◆ 19	046-0220-00-0	1	Gasket-Optional Inspection Port Cover
◆◆ 20	046-1640-00-0	1	Gasket-Pump Body
• 21	046-6020-00-0	1	Gasket-Rear Bearing Housing
22	048-0150-00-0	1	Shim-Bearing
23	062-0110-05-0	1	Cover-Optional Inspection Port
24	062-0770-00-0	1	Housing-Rear Bearing (QFLO-23L, QFLO-15L, QFLO-28X, & QFLO-19X Pumps)
	062-0770-01-0	1	Housing-Rear Bearing (QFLO-21L, QFLO-17L, QFLO-25X, & QFLO-21X Pumps)
	062-0770-02-0	1	Housing-Rear Bearing (QFLO-19L, QFLO-23X Pumps)
• 25	064-5070-01-0	1	Pin-Cotter (5/32 x 2" Lg.)
• 26	077-2120-01-0	1	Ring-Pump Shaft Retaining



**PARTS LIST HALE QFLO SERIES PUMPS  
FIGURE 6-2 (CONTINUED)**

ITEM NO.	PART NO	QTY	DESCRIPTION
27	097-0030-00-0	2	Washer-4-1/2 Suction Tube Cap
	097-0040-00-0	2	Washer-5 Suction Tube Cap
	097-0050-00-0	2	Washer-6 Suction Tube Cap
28	097-0830-01-0	1	Washer-Rear Bearing
29	110-7040-00-0	1	Nut-Impeller
30	178-0020-00-0	2	Extension-Suction Tube
	178-0062-00-0	2	Extension-Suction Tube Long
	178-0062-01-0	2	Extension-Suction Tube Long with Bottom
	178-0063-00-0	2	Extension-Suction Tube MIV
	178-0063-01-0	2	Extension-Suction Tube MIV with Bottom
31	217-0201-00-0	4	Plug-1/4 NPT Black MI
32	217-0301-00-0	2	Plug-3/8 NPT Black MI
33	217-0401-00-0	2	Plug-1/2 NPT Black MI
34	217-0501-00-0	2	Plug-3/4 NPT Black MI
35	250-0211-20-0	2	Bearing-Pump Shaft
36	250-0409-00-0	1	Bearing-Pump Shaft Rear
• 37	296-2090-00-0	1	Seal-Rear Bearing Housing Oil
• 38	296-5210-05-0	1	Seal-Mechanical
39	321-0040-00-0	2	Ring-Impeller Clearance

**REPAIR KITS**

546-0875-50-0	1	Qflo Gasket and Seal Kit includes the above parts marked by •
546-1880-01-0	1	Qflo Pump Level 1 Basic Repair Kit includes the above parts marked by ♦, as well as, the following gearbox parts:
040-2109-00-0	1	Seal Ring-Gearshift Shaft
046-0950-00-0	2	Gasket-Shift Indicator Switch
046-5060-00-0	1	Gasket-Gearshift Cap
046-5130-00-0	2	Gasket-Front & Rear Bearing Cap
046-6370-00-0	1	Gasket-LG Gearbox Housing Cover
142-0160-00-0	1	Slinger
296-2540-00-0	2	Seal-Drive Shaft Oil

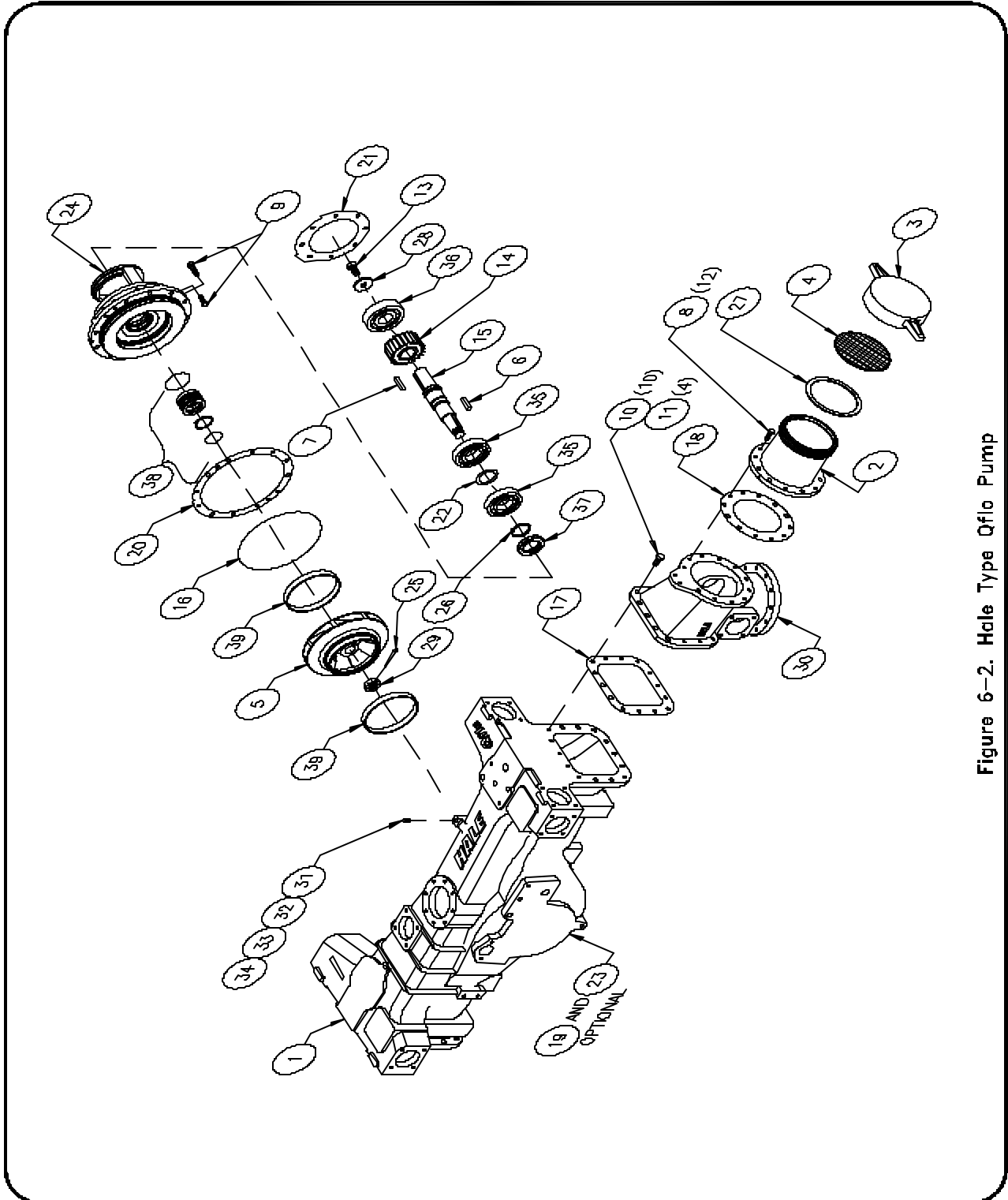

Figure 6-2. Hale Type Qf10 Pump



**PARTS LIST HALE QMAX SERIES PUMPS**  
**FIGURE 6-3**

ITEM NO.	PART NO	QTY	DESCRIPTION
1	001-0870-00-0	1	Body-Pump (Qmax Assembly)
2	018-2016-07-0	15	Screw-1/2-13 x 1-3/4 Lg. Zinc Pl. Stl. 360° Nylon Locking Cap
3	018-2450-02-0	4	Screw-5/8-11 x 5 Lg. Zinc Pl. Stl. Cap
4	046-0940-00-0	1	Gasket-Pump Body
5	064-6010-00-0	2	Pin-Dowel
6	217-0201-00-0	11	Plug-1/4 NPT Black MI
7	217-0301-00-0	3	Plug-3/8 NPT Black MI
8	217-0401-00-0	2	Plug-1/2 NPT Black MI
9	217-0501-00-0	2	Plug-3/4 NPT Black MI
10	007-0020-00-0	2	Tube-5 Suction
	007-0030-00-0	2	Tube-6 Suction
11	008-0020-00-0	2	Cap-5 Suction Tube
	008-0030-00-0	2	Cap-6 Suction Tube
12	010-0020-00-0	2	Strainer-5 Suction Tube
	010-0030-00-0	2	Strainer-6 Suction Tube
13	010-0040-00-0	1	Strainer-Priming Valve
14	012-0160-00-0	1	Handle-Priming Valve Stem
15	016-0081-00-0	1	Impeller
16	017-0120-00-0	1	Key-Impeller
17	017-0300-00-0	1	Key-Pump Shaft Gear
18	018-1606-08-0	2	Screw-3/8-16 x 3/4 Lg. Soc. Hd. Zinc Pl. Stl. Cap
19	018-1812-02-0	94	Screw-7/16-14 x 1-1/4 Lg. Zinc Pl. Stl. Cap
	018-1812-02-0	4	Screw-7/16-14 x 1-1/4 Lg. Zinc Pl. Stl. Cap (Used when R.V. is Omitted)
20	018-1812-07-0	8	Screw-7/16-14 x 1-1/4 Lg. Zinc Pl. Stl. 360° Nylon Locking Cap
21	018-2012-02-0	28	Screw-1/2-13 x 1-1/4 Lg. Zinc Pl. Stl. Cap
22	018-2012-07-0	8	Screw-1/2-13 x 1-1/4 Lg. Zinc Pl. Stl. 360° Nylon Locking Cap
23	018-2016-07-0	12	Screw-1/2-13 x 1-3/4 Lg. Zinc Pl. Stl. 360° Nylon Locking Cap
24	018-2020-07-0	12	Screw-1/2-13 x 2 Lg. Zinc Pl. Stl. 360° Nylon Locking Cap
25	018-2412-07-0	1	Screw-5/8-11 x 1-1/4 Lg. Zinc Pl. Stl. 360° Nylon Locking Cap
26	031-0920-00-0	1	Gear-Pump Shaft (18 Teeth) (QMAX-23L, QMAX-28X Pumps)
	031-0930-00-0	1	Gear-Pump Shaft (20 Teeth) (QMAX-21L, QMAX-25X Pumps)
	031-0940-00-0	1	Gear-Pump Shaft (22 Teeth) (QMAX-19L, QMAX-23X Pumps)
	031-0950-00-0	1	Gear-Pump Shaft (24 Teeth) (QMAX-17L, QMAX-21X Pumps)
	031-0960-00-0	1	Gear-Pump Shaft (26 Teeth) (QMAX-15L, QMAX-19X Pumps)
27	037-1501-00-0	1	Shaft-Pump Packing
	037-1830-00-0	1	Shaft-Pump Mechanical Seal
	040-2260-00-0	1	Seal Ring-Priming Valve Plate
	040-2420-00-0	1	Seal Ring-Relief Valve Plug (Used when R.V. is Omitted)
28	040-2550-00-0	1	Seal Ring-Packing Housing Seal
29	042-0010-00-0	1	Spring-Packing Gland Lock
30	044-0280-00-0	1	Cover-Front Bearing Housing
31	046-0030-00-0	2	Gasket-Suction Tube Extension
32	046-0040-00-0	2	Gasket-Suction Tube





**PARTS LIST HALE QMAX SERIES PUMPS  
FIGURE 6-3 (CONTINUED)**

ITEM NO.	PART NO	QTY	DESCRIPTION
	046-0050-00-0	10	Gasket-Flange
	046-0060-00-0	3	Gasket-Tank Connection Flange
	046-0080-00-0	1	Gasket-Relief Valve (Used when R.V. is Omitted)
33	046-0220-00-0	3	Gasket-Front Cover
34	046-5170-00-0	1	Diaphragm-Front Bearing Housing
35	046-6020-00-0	1	Gasket-Rear Bearing Housing Cover (LG and XG Gearbox)
	046-6460-00-0	1	Gasket-Rear Bearing Housing Cover (SG Gearbox)
36	048-0200-00-0	1	Gland-Rear Packing
37	048-0210-00-0	1	Gland-Front Packing
38	048-0220-00-1	1	Lantern Packing
39	048-0230-00-0	1	Sleeve-Packing Gland Adjusting
40	062-0120-00-0	1	Housing-Packing
	062-0680-00-0	1	Housing-Mechanical Seal
41	062-0130-00-0	1	Housing-Rear Bearing
			(QMAX-23L, QMAX-23S, QMAX-15L, QMAX-28X, QMAX-19X Pumps)
	062-0140-00-0	1	Housing-Rear Bearing
			(QMAX-21L, QMAX-21S, QMAX-17L, QMAX-25X, QMAX-21X Pumps)
	062-0150-00-0	1	Housing-Rear Bearing (QMAX-19L, QMAX-19S, QMAX-23X Pumps)
42	064-1016-01-0	1	Pin-Packing Sleeve Lock
43	064-1416-12-0	1	Pin-Cooling Line
44	077-1500-25-0	1	Ring-Impeller Retaining
45	077-1871-20-0	1	Ring-Oil Seal Retaining
46	097-0040-00-0	2	Washer-5 Suction Tube Cap
	097-0050-00-0	2	Washer-6 Suction Tube Cap
47	097-0230-00-0	6	Separators-Packing
48	097-0830-01-0	1	Washer-Rear Bearing
	101-0381-00-0	1	Plate-Operator Panel
	115-0010-00-0	3	Flange-Blank-Off & Tank Connection
	115-0050-00-0	10	Flange-Blank-Off
49	142-0010-00-0	1	Slinger-Pump Shaft
50	178-0020-00-0	2	Extension-Suction Tube
	178-0062-00-0	2	Extension-Suction Tube Long
	178-0062-01-0	2	Extension-Suction Tube Long with Bottom
	178-0063-00-0	2	Extension-Suction Tube MIV
	178-0063-01-0	2	Extension-Suction Tube MIV with Bottom
51	217-0201-00-0	2	Plug-1/4 NPT Hex Hd. Brass
	217-3001-00-0	1	Plug-Relief Valve (When Pump is furnished without Relief Valve, Use (4) 7/16-14 x 1-1/4 Lg. Zinc Pl. Stl. 360° Nylon Cap Screws – Item No. 31, Hale Part No. 018-1812-07-0)
52	250-0310-00-0	1	Bearing-Rear (Inside)
53	250-0409-00-0	1	Bearing-Rear (Outside)
54	296-0030-02-0	4	Packing-Pump Shaft
55	296-2050-00-0	1	Seal-Rear Bearing Housing Oil
56	296-2080-00-0	1	Seal-Front Bearing Housing Oil



---

**PARTS LIST HALE QMAX SERIES PUMPS  
FIGURE 6-3 (CONTINUED)**

<b>ITEM NO.</b>	<b>PART NO</b>	<b>QTY</b>	<b>DESCRIPTION</b>
57	296-5210-05-0	1	Seal-Mechanical
58	321-0371-00-0	2	Ring-Impeller Clearance
	518-0030-00-0	1	Screw Pack for Panel Plate (Item No. 85, Part No. 101-0381-00-0)
59	562-0090-00-0	1	Housing-Front Bearing (Assembly)
60	062-0110-00-0	1	Housing-Front Bearing
61	250-9100-00-0	1	Bearing-Front Sleeve
62	564-0010-00-0	1	Pin-Packing Gland Lock
63	044-1250-00-0	1	Cover-Mechanical Seal
64	040-2260-10-0	2	Seal Ring-Mechanical Seal
65	040-2340-00-0	1	Seal Ring-Mechanical Seal Cover
66	077-2000-21-0	2	Retaining Ring-Mechanical Seal Housing
67	529-0020-00-0	1	Plate-Panel Instruction (Assembly)
68	546-0720-00-0	1	Light-Throttle Indicator (Assembly)
	101-0252-00-0	1	Plate-Indicator Light
	101-0291-00-0	1	Plate-Throttle Instruction
	200-0540-00-0	3	Light Only (Green)
	200-0540-02-0	3	Bulb Only
	200-0540-12-0	3	Indicator Light Body
	200-0540-14-0	3	Green Lens

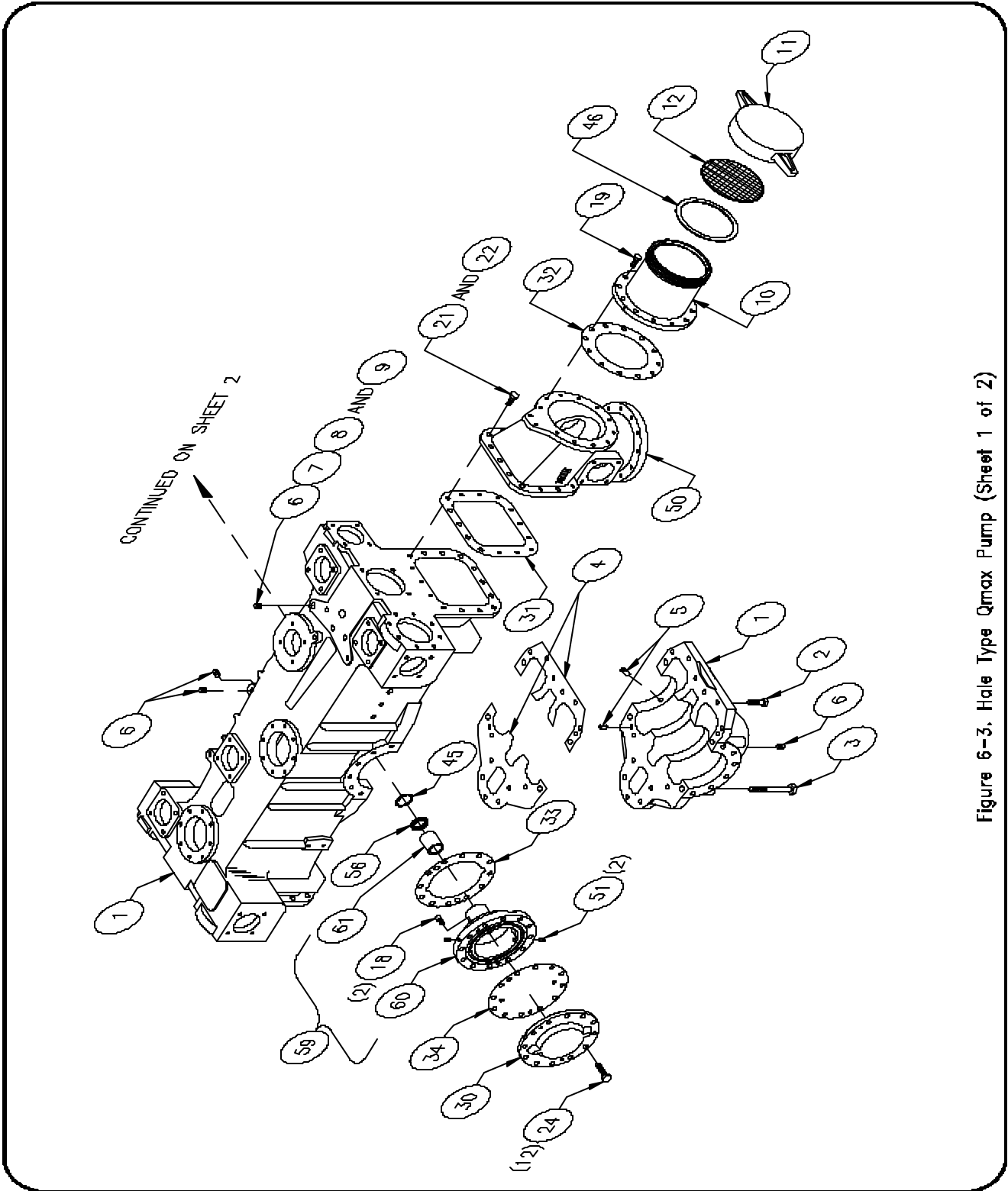

Figure 6-3. Hale Type Qmax Pump (Sheet 1 of 2)

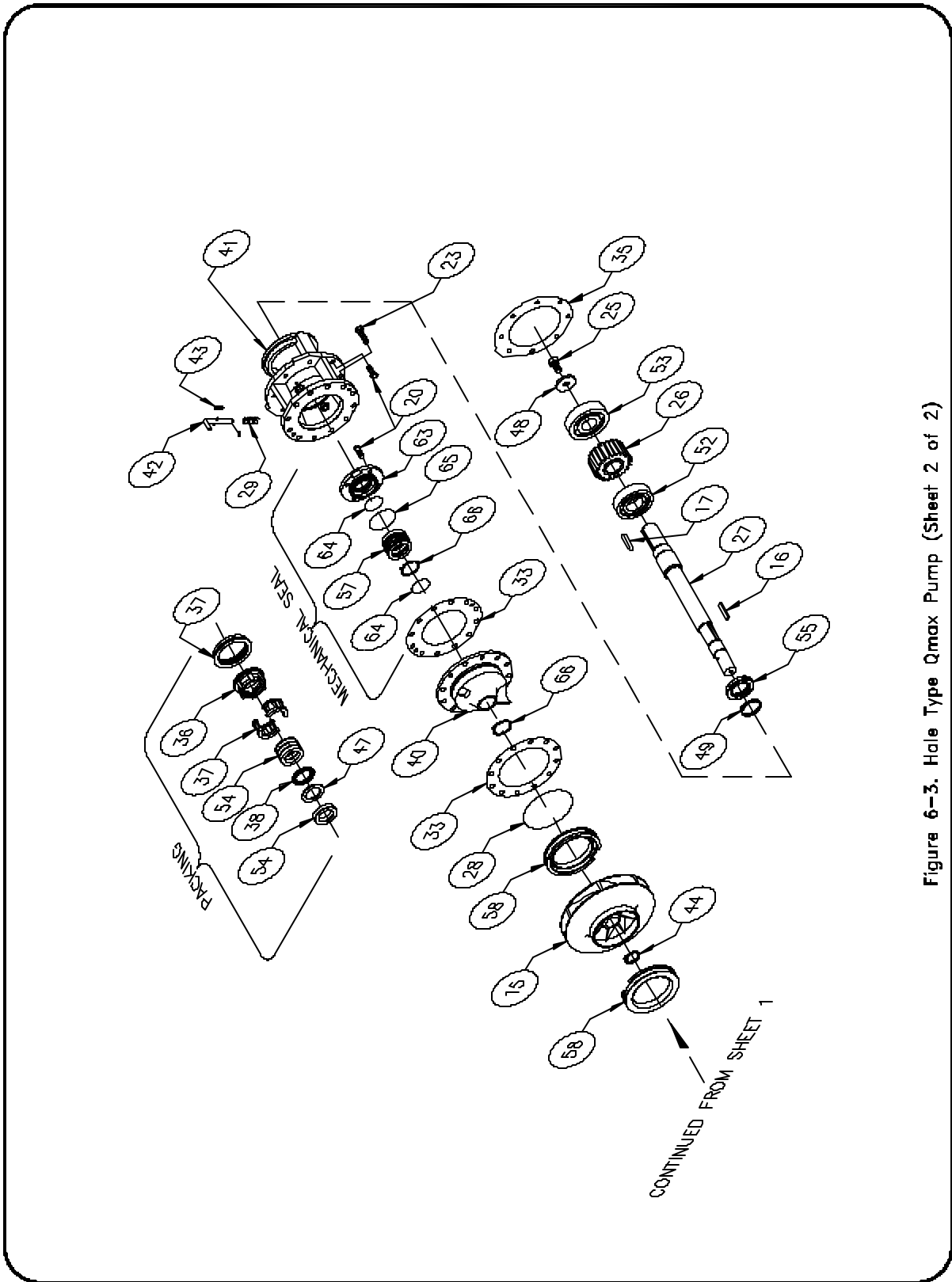

Figure 6-3. Hale Type Qmax Pump (Sheet 2 of 2)



**PARTS LIST HALE QTWO SERIES PUMPS**  
**FIGURE 6-4**

ITEM NO.	PART NO	QTY	DESCRIPTION
1	001-0880-00-0	1	Body-Pump (Qtwo Assembly)
2	018-2016-07-0	15	Screw-1/2-13 x 1-3/4 Lg. Zinc Pl. Stl. 360° Nylon Locking Cap
3	018-2450-02-0	4	Screw-5/8-11 x 5 Lg. Zinc Pl. Stl. Cap
4	046-0021-00-0	1	Gasket-Pump Body
5	064-6010-00-0	2	Pin-Dowel
6	217-0201-00-0	11	Plug-1/4 NPT Black MI
7	217-0301-00-0	3	Plug-3/8 NPT Black MI
8	217-0401-00-0	2	Plug-1/2 NPT Black MI
9	217-0501-00-0	2	Plug-3/4 NPT Black MI
10	007-0020-00-0	2	Tube-5 Suction
	007-0030-00-0	2	Tube-6 Suction
11	008-0020-00-0	2	Cap-5 Suction Tube
	008-0030-00-0	2	Cap-6 Suction Tube
12	010-0020-00-0	2	Strainer-5 Suction Tube
	010-0030-00-0	2	Strainer-6 Suction Tube
13	016-0772-00-0	1	Impeller-Front
14	016-0782-00-0	1	Impeller-Rear
15	017-0150-00-0	1	Key-Impeller
16	017-0300-00-0	1	Key-Pump Shaft Gear
17	018-1606-08-0	2	Screw-3/8-16 x 3/4 Lg. Soc. Hd. Zinc Pl. Stl. Cap
18	018-1812-02-0	90	Screw-7/16-14 x 1-1/4 Lg. Zinc Pl. Stl. Cap
19	018-1812-07-0	8	Screw-7/16-14 x 1-1/4 Lg. Zinc Pl. Stl. 360° Nylon Locking Cap
20	018-2012-02-0	28	Screw-1/2-13 x 1-1/4 Lg. Zinc Pl. Stl. Cap
21	018-2012-07-0	36	Screw-1/2-13 x 1-1/4 Lg. Zinc Pl. Stl. 360° Nylon Locking Cap
22	018-2016-07-0	12	Screw-1/2-13 x 1-3/4 Lg. Zinc Pl. Stl. 360° Nylon Locking Cap
23	018-2020-07-0	12	Screw-1/2-13 x 2 Lg. Zinc Pl. Stl. 360° Nylon Locking Cap
24	018-2412-07-0	1	Screw-5/8-11 x 1-1/4 lg. Zinc Pl. Stl. 360° Nylon Locking Cap
25	031-0920-00-0	1	Gear-Pump Shaft (18 Teeth) (QTWO-23L, QTWO-23S, QTWO-28X Pumps)
	031-0930-00-0	1	Gear-Pump Shaft (20 Teeth) (QTWO-21L, QTWO-21S, QTWO-25X Pumps)
	031-0940-00-0	1	Gear-Pump Shaft (22 Teeth) (QTWO-19L, QTWO-19S, QTWO-23X Pumps)
	031-0950-00-0	1	Gear-Pump Shaft (24 Teeth) (QTWO-17L, QTWO-17S, QTWO-21X Pumps)
	031-0960-00-0	1	Gear-Pump Shaft (26 Teeth) (QTWO-15L, QTWO-17S, QTWO-19X Pumps)
26	037-1521-00-0	1	Shaft-Pump Packing
	037-1740-00-0	1	Shaft-Pump Mechanical Seal
27	038-0080-00-0	2	Valve-Suction Check
28	040-2550-00-0	1	Seal Ring-Head
29	042-0010-00-0	1	Spring-Packing Gland Lock
30	044-0100-00-0	2	Cover-Check Valve
31	044-0280-00-0	1	Cover-Front Bearing Housing
32	046-0030-00-0	2	Gasket-Suction Tube Extension
33	046-0040-00-0	2	Gasket-Suction Tube
34	046-0220-00-0	3	Gasket-Front Cover
35	046-6020-00-0	1	Diaphragm-Front Bearing Housing
36	046-6020-00-0	1	Gasket-Rear Bearing Housing Cover (LG and XG Gearbox)



**PARTS LIST HALE QTWO SERIES PUMPS  
FIGURE 6-4 (CONTINUED)**

ITEM NO.	PART NO	QTY	DESCRIPTION
	046-6460-00-0	1	Gasket-Rear Bearing Housing Cover (SG Gearbox)
37	048-0200-00-0	1	Gland-Rear Packing
38	048-0210-00-0	2	Gland-Front Packing
39	048-0220-00-1	2	Lantern Packing
40	048-0230-00-0	1	Sleeve-Packing Gland Adjusting
41	062-0120-00-0	1	Housing-Packing
	062-0680-00-0	1	Housing-Mechanical Seal
42	062-0130-00-0	1	Housing-Rear Bearing (QTWO-23L, QTWO-23S, QTWO-15L, QTWO-28X, QTWO-19X Pumps)
	062-0140-00-0	1	Housing-Rear Bearing (QTWO-21L, QTWO-21S, QTWO-17L, QTWO-25X, QTWO-21X Pumps)
	062-0150-00-0	1	Housing-Rear Bearing (QTWO-19L, QTWO-19s, QTWO-23X Pumps)
43	062-0573-00-0	1	Housing-Center Bearing
44	064-1016-01-0	1	Pin-Packing Sleeve Lock
45	064-1416-12-0	1	Pin-Cooling Line
46	077-1500-25-0	1	Ring-Impeller Retaining
47	077-1871-20-0	1	Ring-Oil Seal Retaining
48	097-0040-00-0	2	Washer-5 Suction Tube Cap
	097-0050-00-0	2	Washer-6 Suction Tube Cap
49	097-0230-00-0	6	Separators-Packing
50	097-0830-01-0	1	Washer-Rear Bearing
51	142-0010-00-0	1	Slinger-Pump Shaft
52	142-0530-00-0	1	Ring-Check Valve Cover Seal
53	178-0020-00-0	2	Extension-Suction Tube Standard
	178-0062-00-0	2	Extension-Suction Tube Long (For use with 25BS Suction Valve)
	178-0062-01-0	2	Extension-Suction Tube Long with Bottom
	178-0063-00-0	2	Extension-Suction Tube MIV
	178-0063-01-0	2	Extension-Suction Tube MIV with Bottom
54	217-0201-00-0	2	Plug-1/4 NPT hex Hd. Brass
55	250-0310-00-0	1	Bearing-Rear (Inside)
56	250-0409-00-0	1	Bearing-Rear (Outside)
57	296-0030-02-0	4	Packing-Pump Shaft
58	296-2050-00-0	1	Seal-Rear Bearing Housing Oil
59	296-2080-00-0	1	Seal-Front Bearing Housing Oil
60	296-5210-05-0	1	Seal-Mechanical
61	321-0371-00-0	2	Ring-Impeller Clearance
62	562-0090-00-0	1	Housing-Front Bearing (Assembly)
63	062-0110-00-0	1	Housing-Front Bearing
64	250-9100-00-0	1	Bearing-Front Sleeve
65	564-0010-00-0	1	Pin-Packing Gland Lock
66	077-2000-21-0	2	Ring-Retaining
67	040-2260-10-0	2	Seal-Ring
68	044-1250-00-0	1	Cover-Mechanical Seal
69	040-2340-00-0	1	Seal Ring-Mechanical Seal Cover

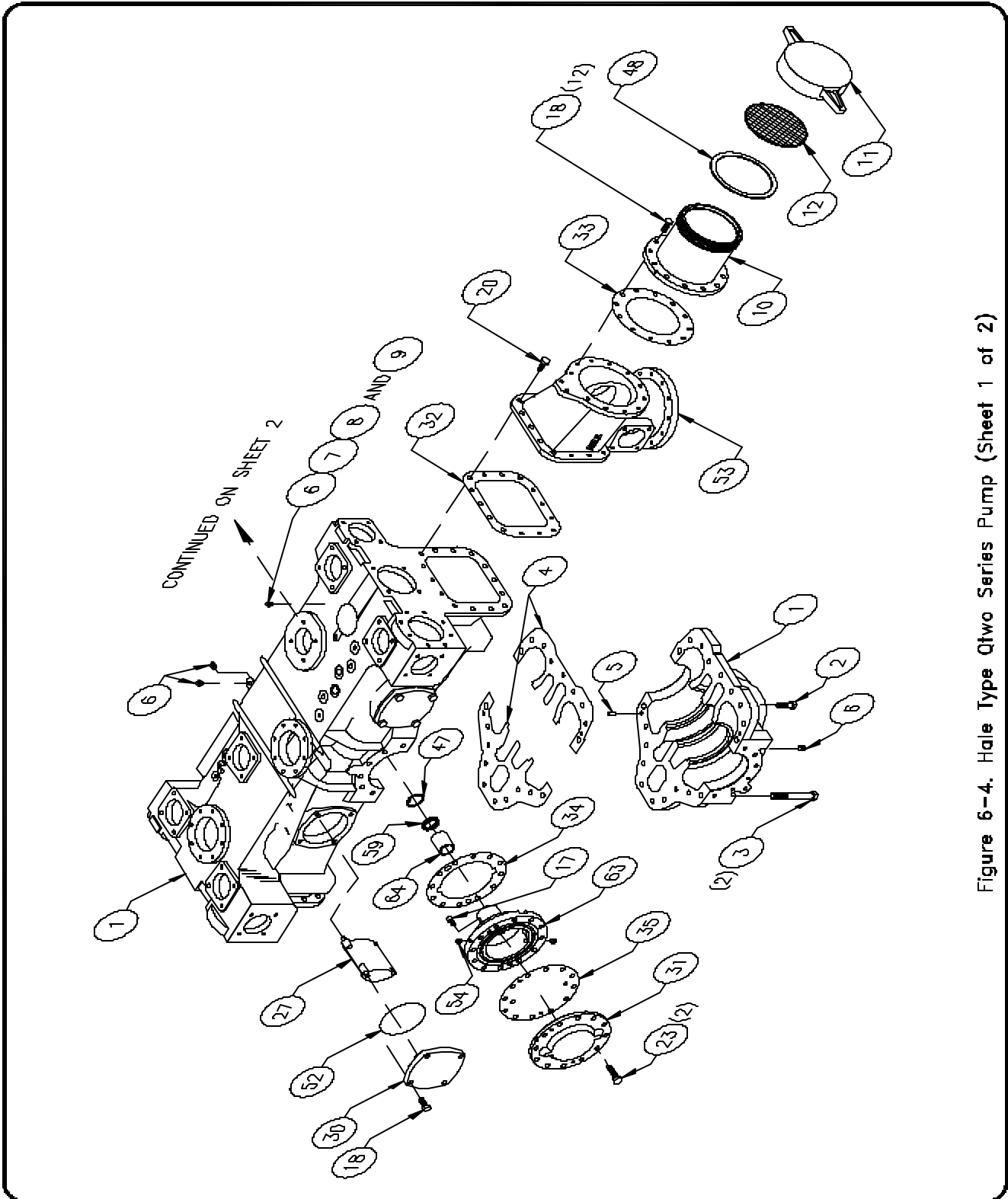

Figure 6-4. Hale Type Qtwo Series Pump (Sheet 1 of 2)



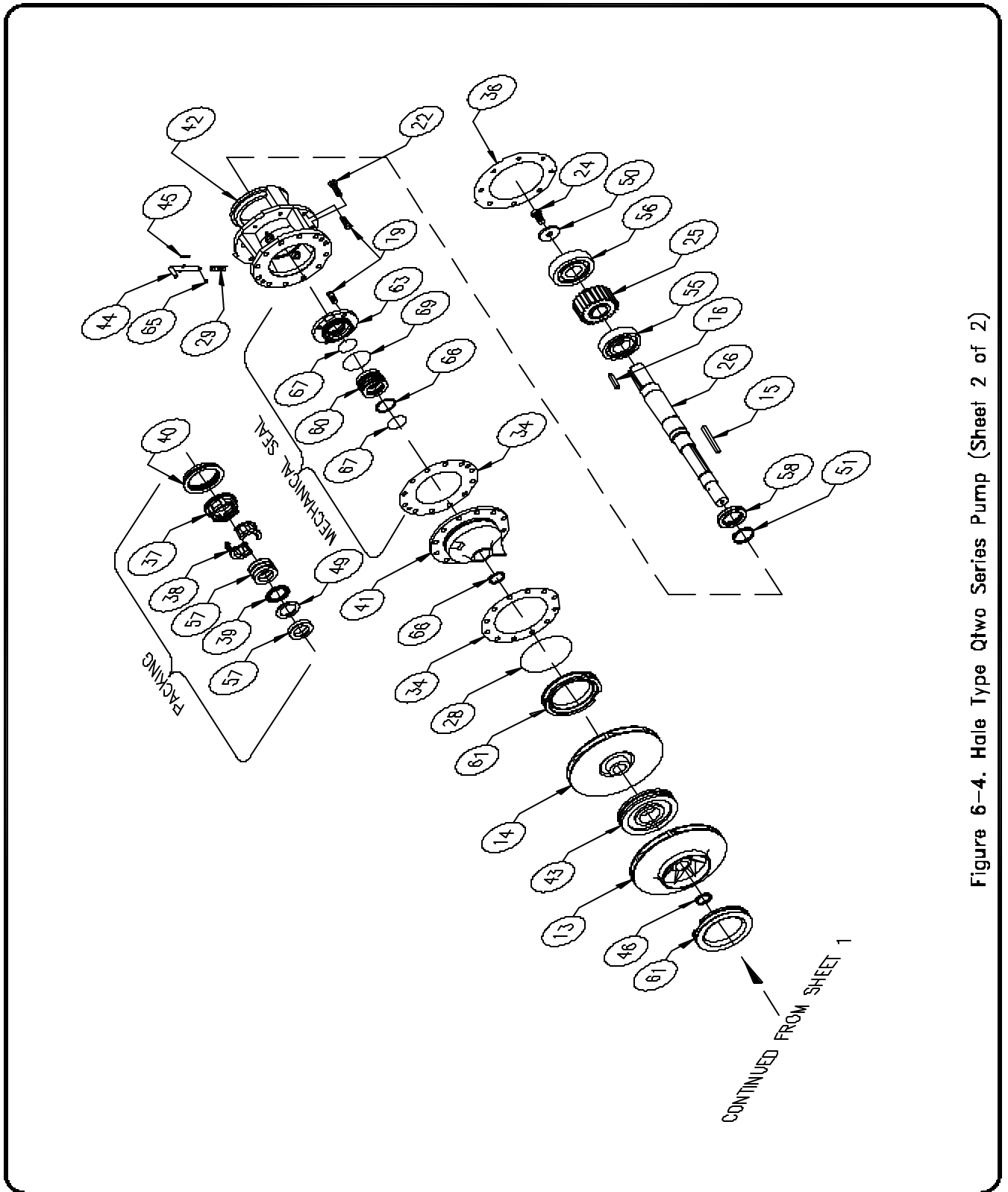

Figure 6-4. Hale Type Qtwo Series Pump (Sheet 2 of 2)



**PARTS LIST HALE TYPE "G" SERIES GEARBOX  
FIGURE 6-5**

ITEM NO.	PART NO	QTY	DESCRIPTION
1	007-0100-00-0	1	Tube-Drive Unit Cooling (LG & XG Gear Box) (Qmax/Qtwo)
	007-0170-00-0	1	Tube-Drive Unit Cooling (SG Gear Box) (Qmax/Qtwo)
2	008-0053-02-0	1	Cap-Gearshift Shaft
3	008-0560-00-0	1	Cap-Rear Bearing
4	008-0570-00-0	1	Cap-Front Bearing
5	018-1810-07-0	12	Screw-7/16-14 x 1 Lg. Hex Hd. Zinc Pl. Stl. 360° Nylon Locking Cap
6	018-1816-02-0	1	Screw-7/16-14 x 1-3/4 Lg. Hex Hd. Zinc Pl. Stl. Cap
7	018-1822-02-0	2	Screw-7/16-14 x 2-1/4 Lg. Hex Hd. Zinc Plated Stl. Cap (For Shipping Only) (Not Shown)
8	018-2104-61-0	1	Screw-1/2-20 x 1/2 Lg. Flat Point Zinc Pl. Stl. 360° Nylon Locking Cap
9	018-5002-00-0	4	Screw No. 4 x 1/4 Lg. Rd. Hd. Zinc Pl. Drive
10	018-1810-190-0	2	Screw-7/16-14, Socket Head Cap Screw
11	028-0041-02-0	1	Fork-Gearshift (LG & SG Gearbox)
	028-0400-00-0	1	Fork-Gearshift (XG Gearbox)
12	028-0050-00-0	1	Rod End-Gearshift Shaft
13	031-0970-00-0	1	Gear-Sliding (41 Teeth) (LG & SG GEARBOX)
	031-1300-00-0	1	Gear-Sliding (51 Teeth) (XG Gearbox)
14	031-1310-00-0	1	Gear-Intermediate (59 Teeth) (XG Gearbox)
	031-0980-00-0	1	Gear-Intermediate (51 Teeth) (LG Gearbox)
	031-1040-00-0	1	Gear-Intermediate (40 Teeth) (SG Gearbox)
15	037-1341-00-0	1	Shaft-Gearshift
16	037-1530-00-0	1	Shaft-Intermediate Gear
17	039-0050-00-0	1	Ball-Gearshift Shaft
18	040-0140-00-0	2	Ring-Switch Seal Ring
19	040-2109-00-0	1	Ring-Gearshift Shaft Seal
20	040-2240-00-0	1	Ring-Intermediate Shaft Seal
21	040-2280-00-0	1	Ring-Intermediate Shaft Seal
22	042-0060-00-0	1	Spring-Gearshift Shaft Lock
23	044-0260-00-0	1	Vent-Air
24	046-5060-00-0	1	Gasket-Gearshift Cap
25	046-5130-00-0	2	Gasket-Front & Rear Bearing Cap
26	048-0070-00-0	1	Bushing-Speedcounter Drive
37	077-2750-01-0	4	Ring-Tailshaft & Sliding Gear Retaining
28	077-5000-00-0	1	Ring-Tailshaft Bearing Retaining
29	088-0040-00-0	2	Connector-Cooling Tube (Qmax/Qtwo)
	217-0401-00-0	2	Plug-1/2 NPT MI (Qflo only)
30	097-1330-00-0	1	Washer-Intermediate Shaft
31	101-0082-00-0	1	Plate-Serial Number
32	101-0310-00-0	1	Tag-Oil Warning (Not Shown)
33	101-0941-00-0	1	Tag-Warning (Not Shown)
34	110-1600-02-0	1	Nut-3/8-16 Zinc Pl. Stl. Hex



**PARTS LIST HALE TYPE "G" SERIES GEARBOX  
FIGURE 6-5 (CONTINUED)**

<b>ITEM NO.</b>	<b>PART NO</b>	<b>QTY</b>	<b>DESCRIPTION</b>
35	115-0090-00-0	1	Cover-Gearshift Shaft Front
36	142-0160-00-0	1	Slinger
37	159-1460-00-0	1	Spacer-Intermediate Gear (XG Gearbox)
38	200-2450-00-0	2	Switch-Gearshift
39	217-0501-00-0	1	Plug-3/4 NPT Black MI (Oil Fill & Drain)
40	217-0501-08-0	1	Plug-3/4 NPT Magnetic (Oil Drain)
41	217-3007-00-0	1	Plug-Speedcounter
42	250-0214-00-0	1	Bearing-Tail Shaft
43	250-0214-06-0	2	Bearing-Sliding Gear & Tail Shaft
44	250-8010-00-0	1	Bearing-Sliding Gear Shaft Needle
45	250-8040-00-0	1	Bearing-Intermediate Gear
46	296-2540-00-0	2	Seal-Drive Shaft Oil
47	504-0380-00-0	1	Housing-Gearbox (Assembly)(SG Gearbox)
	504-0340-00-0	1	Housing-Gearbox (Assembly) (LG Gearbox Optional)
	504-0510-00-0	1	Housing-Gearbox (Assembly) (XG Gearbox Optional)
48	018-2014-07-0	6	Screw-1/2-13 x 1-1/2 Lg. Hex Zinc Pl. Stl. Nylon Locking Cap
49	046-6370-00-0	1	Gasket-Housing Cover (LG & SG Gearbox)
	046-6370-01-0	1	Gasket-Housing Cover (XG Gearbox)
50	537-1740-00-0	1	Shaft-Sliding Gear (Assembly)
	159-0610-00-0	8	Spacer
51	537-1750-00-0	1	Shaft-Tailshaft (Assembly)
52	101-1730-00-0	2	G-Flange Instruction Tag

**OPTIONAL SPEEDCOUNTER ATTACHMENT**

**ADD THE FOLLOWING PARTS TO THE 'G' SERIES GEARBOX**

53	007-0040-00-0	1	Adapter-Speedcounter
	008-0070-00-0	1	Cap-Speedcounter Drive Sleeve (Not Shown, Panel Mounted Component)
	013-0010-00-0	1	Shaft-Speedcounter Flexible (Not Shown, Panel Mounted Component)
54	031-0170-00-0	1	Gear-Speedcounter Driven
	048-0090-00-0	1	Sleeve-Speedcounter Drive (Not Shown, Panel Mounted Component)
55	040-0180-00-0	1	Ring-Speedcounter Adapter Seal

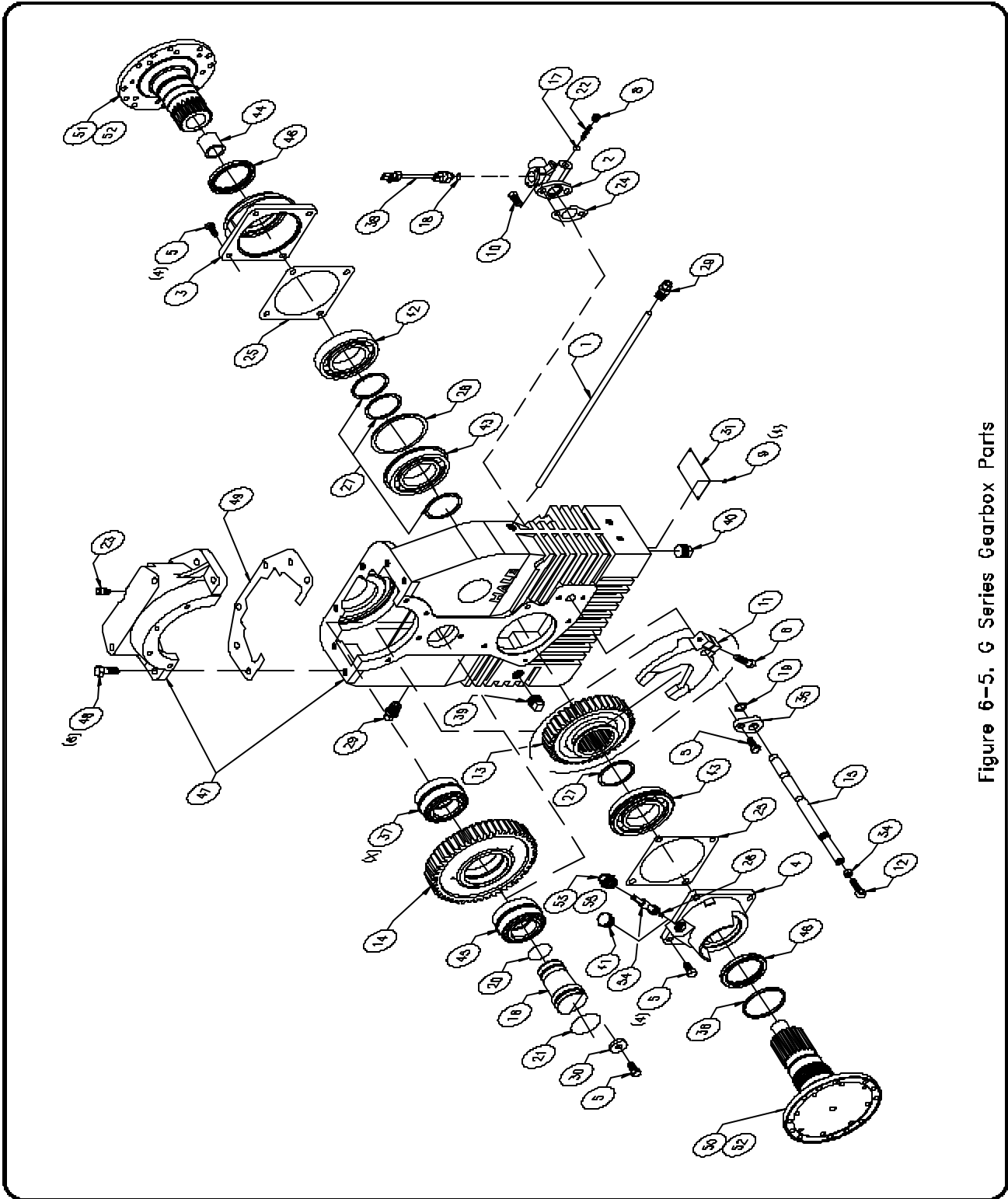

Figure 6-5. G Series Gearbox Parts



**PARTS LIST HALE TYPE "J" SERIES GEARBOX  
FIGURE 6-6**

ITEM NO.	PART NO.	QTY.	DESCRIPTION
1	004-0590-01-0	1	Housing - Lower J-Gearbox
2	004-0590-02-0	1	Housing - Upper J-Gearbox
3	018-2074-02-0	4	Screw - 1/2-13 UNC X 7.5 in. Lg. (1.63 (-16) J-Gearbox Ratio)
	018-2070-02-0	4	Screw - 1/2-13 UNC X 7.0 in. Lg. (1.80 (-18) and 2.08 (-21) J-Gearbox Ratios)
	018-2064-02-0	4	Screw - 1/2-13 UNC X 6.5 in. Lg. (2.35 (-23) and 2.57 (-25) J-Gearbox Ratios)
4	018-2036-02-0	4	Screw - 1/2-13 UNC X 3.75 in. Lg. (1.63 (-16) J-Gearbox Ratio)
	018-2034-02-0	4	Screw - 1/2-13 UNC X 3.5 in. Lg. (1.80 (-18) and 2.08 (-21) J-Gearbox Ratios)
	018-2030-02-0	4	Screw - 1/2-13 UNC X 3.0 in. Lg. (2.35 (-23) and 2.57 (-25) J-Gearbox Ratios)
5	008-0810-00-0	1	Cap - End Upper Housing
6	018-2012-02-0	4	Screw - 1/2-13 UNC X 1-1/4 in. Lg. Upper Housing End Cap
7	044-0260-00-0	1	Vent - Breather Upper Housing End Cap
8	046-1650-00-0	1	Gasket - Upper Housing End Cap
9	064-6410-00-0	2	Pin - Dowel
10	046-1690-00-0	1	Gasket - Spacer
11	159-1600-03-0	1	Spacer - Gear (1.63 (-16) J-Gearbox Ratio)
	159-1600-02-0	1	Spacer - Gear (1.80 (-18) J-Gearbox Ratio)
	159-1600-01-0	1	Spacer - Gear (2.08 (-21) J-Gearbox Ratio)
	159-1600-00-0	1	Spacer - Gear (2.35 (-23) J-Gearbox Ratio)
12	046-1690-00-0	1	Gasket - Spacer (Not used on 2.57 (-25) J-Gearbox Ratio)
13	110-3505-99-0	1	Nut - Locking, Idler Shaft
14	097-2170-00-0	1	Washer - Idler Shaft Nut
15	250-8220-00-0	2	Bearing - Tapered Roller, Idler Shaft
16	031-1600-00-0	1	Gear - Helical (57 teeth)
17	037-2250-00-0	1	Shaft - Idler
18	040-2210-00-0	1	O Ring - Idler Shaft
19	040-2280-00-0	1	O Ring - Idler Shaft
20	018-2012-02-0	1	Screw - 1/2-13 UNC X 1-1/4 in. Lg.
21	097-0890-01-0	1	Washer
22	115-1510-00-0	1	Flange - Companion
23	296-2100-00-0	2	Seal - Oil
24	077-3930-00-0	2	Ring - Retaining
25	250-8200-00-0	1	Bearing - Spherical Roller
26	037-2240-00-0	1	Shaft - Input
27	017-0300-02-0	1	Key - Companion Flange
28	017-0650-01-0	1	Key - Input Shaft Gear
29	031-1540-00-0	1	Gear - Helical (54 teeth)
30	250-0309-00-0	1	Bearing - Deep Groove Ball
31	217-3370-00-0	1	Gauge - View 1/2 NPT
32	217-0401-00-0	1	Plug - 1/2 NPT
33	217-0401-08-0	1	Plug - Magnetic 1/2 NPT

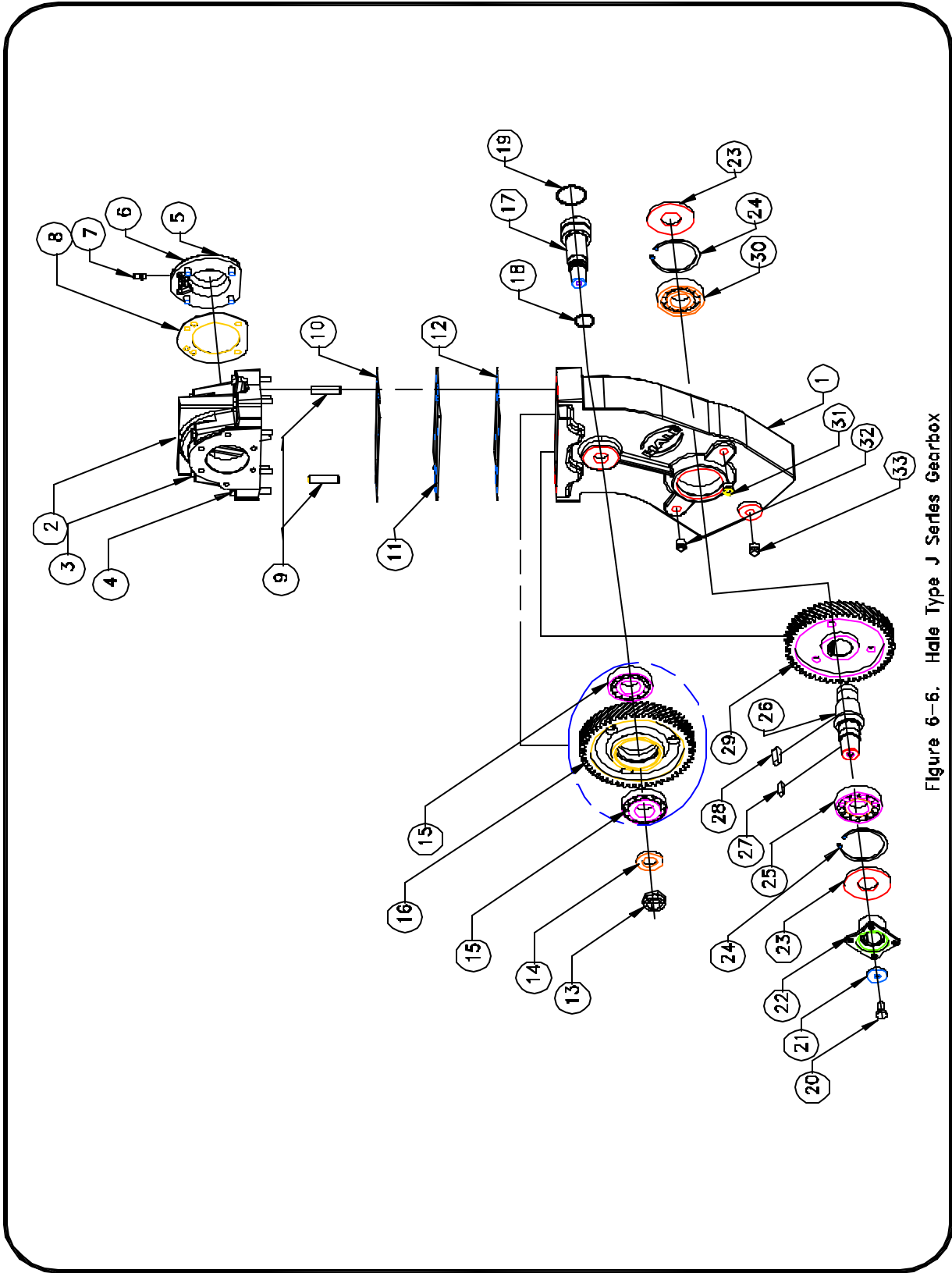

Figure 6-6. Hale Type J Series Gearbox



**PARTS LIST HALE TYPE ESP PRIMING PUMP  
FIGURE 6-7**

ITEM NO.	PART NO	QTY	DESCRIPTION
1	018-1624-02-0	1	Screw-3/8-16 x 2-1/2 Lg. Zinc Pl. Stl. Hex Hd Cap
2	018-8150-00-0	1	Stud-Terminal
3	064-6311-01-0	2	Pin-Locating
4	101-1580-00-0	1	Decal-ESP Model
5	101-1590-00-0	1	Tag-Instruction (Not Shown)
6	110-1600-02-0	2	Nut-3/8-16 Zinc Pl. Stl. Hex
7	130-0010-01-0	4	Vane-Rotor
	200-0041-00-0	1	Motor-Priming Pump (12 Volt)
8	200-0062-00-0	1	Motor-Priming Pump (24 Volt)
9	217-0101-13-0	1	Plug-1/8 NPT Soc. Hd, Brass
10	296-2710-00-0	1	Seal-Head Shaft
11	501-1810-01-0	1	Body-Pump (Assembly)
12	001-0131-01-0	1	Body-Pump
13	250-9111-00-0	1	Bearing-Pump
14	502-0061-01-0	1	Head-Pump Mounting (Assembly)
15	002-0111-01-0	1	Head-Pump Mounting
16	250-9111-00-0	1	Bearing-Head
17	513-0190-00-0	1	Strap-Ground (Chassis Mount)
18	537-0281-01-0	1	Shaft-Pump (Assembly)
19	016-0171-01-0	1	Rotor
20	037-0271-00-0	1	Shaft-Pump

**ADDITIONAL PARTS REQUIRED**

**WHEN THE PRIMING PUMP IS MOUNTED ON THE GEARBOX WITH PVG**

018-1812-07-0	2	Screw-7/16-14 x 1/4 Lg. Zinc Pl. Stl. Nylon Locking Hex Hd. Cap
097-0250-00-0	2	Washer-Mounting

**ADDITIONAL PARTS REQUIRED**

**WHEN THE PRIMING PUMP IS MOUNTED ON THE GEARBOX WITH SPV**

018-1812-07-0	2	Screw-7/16-14 x 1-1/4 Lg. Zinc Pl. Stl. Nylon Locking Hex Hd. Cap
097-0250-00-0	2	Washer-Mounting
082-4027-00-0	1	3/4 NPT Brass Street Elbow
082-0547-02-0	1	3/4 NPT x 3/4 Hose Barb Brass Fitting
340-0230-03-0	AR	3/4 Inch Inside Diameter Vacuum Hose (H03912)



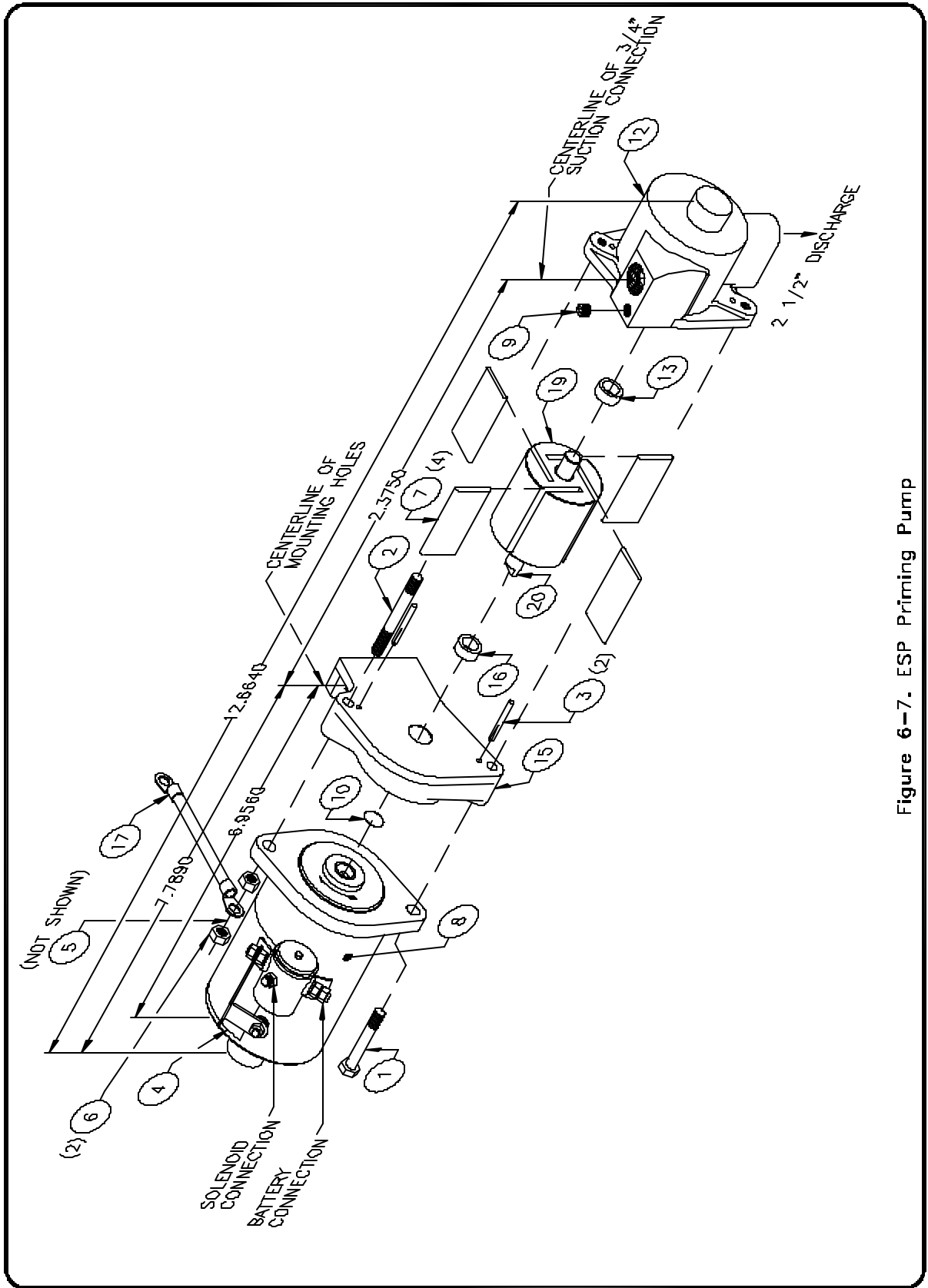

Figure 6-7. ESP Priming Pump



---

**PARTS LIST HALE TYPE SPV PRIMING VALVE  
SEMI-AUTOMATIC  
FIGURE 6-8**

<b>ITEM NO.</b>	<b>PART NO</b>	<b>QTY</b>	<b>DESCRIPTION</b>
1	340-0640-00-1	AR	3/4 ID Hose (Aeroquip 2556-12 or Equal)
2	110-1800-02-0	2	Nut, 7/16-14 Zinc Plated
3	018-8040-00-0	2	Stud, 7/16-14 x 1-3/4 In. Lg. Zinc Plated
4	010-0040-00-0	1	ZMQ-329H PRM Valve Strainer
5	040-2260-00-0	1	40-4N200 Ring Seal
6	018-1406-07-0	8	Screw, 5/16-18 x 3/4 In. Lg.
7	044-0231-00-0	1	Diaphragm Cover (Painted)
8	046-0121-00-0	1	Diaphragm, 5-3/8 In. Dia.
9	018-1004-32-0	1	Screw, #10-24 x 1/2 In. Lg.
10	005-0021-00-0	1	SPV Diaphragm Plate
11	042-0081-00-0	1	Valve Return Spring, Stainless
12	038-0151-00-0	1	SPV Priming Valve Valve
13	082-4027-00-0	1	Street Elbow, 3/4 Male NPT x 3/4 Female NPT
14	082-4027-01-0	1	Connection, 3/4 Male NPT x 3/4 Hose Barb
15	038-0141-00-0	1	SPV Priming Valve Body
16	101-0050-01-0	1	SPV Prime Placard
17	200-0120-04-0	1	Starter Switch, Momentary Push
18	082-0501-02-0	1	3/4 NPT Brass Close Nipple
19	038-1630-03-0	1	3/4 NPT Inline Check Valve
20	007-3370-00-0	1	Universal Mounting Adapter

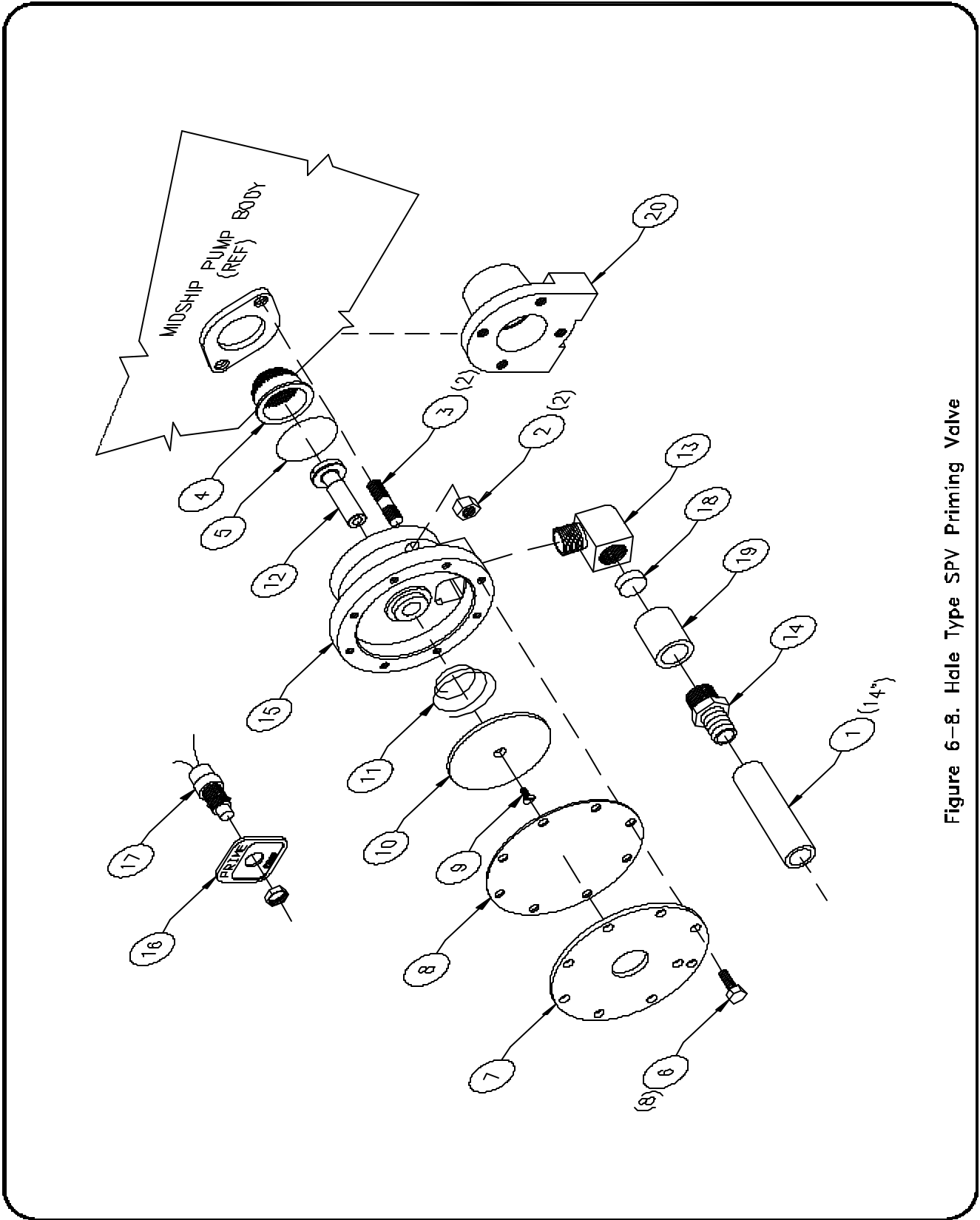
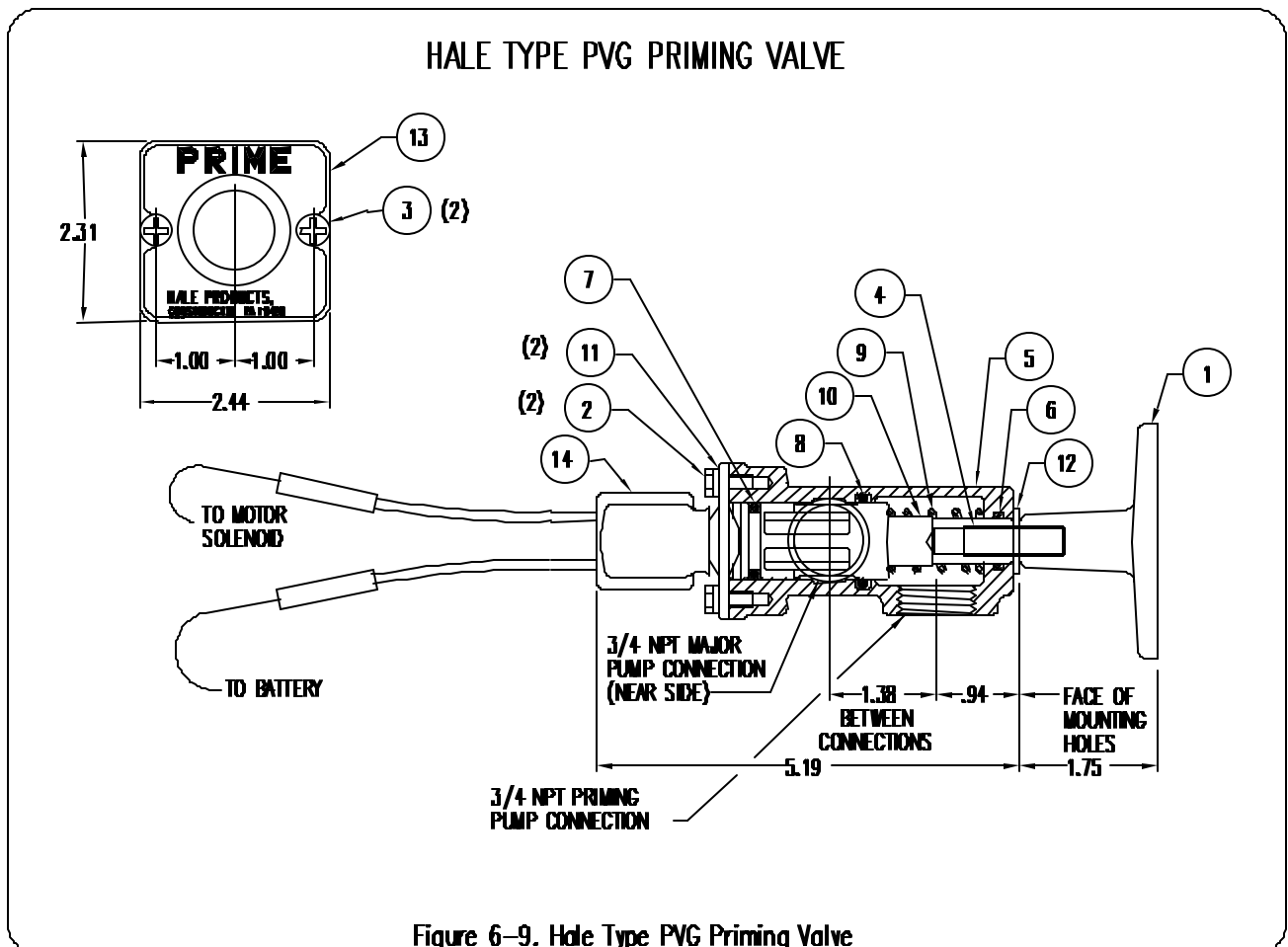

Figure 6-8. Hale Type SPV Priming Valve



**PARTS LIST HALE TYPE PVG PRIMING VALVE  
FIGURE 6-9**

ITEM NO.	PART NO	QTY	DESCRIPTION
1	012-0160-00-0	1	Handle
2	018-1104-02-0	2	Screw-#10-32 x 1/2 Lg. Hex Hd. Zinc Pl. Stl. Cap
3	018-1205-44-0	2	Screw-1/4-20 x 5/8 Lg. P.H. Rd. Hd. SST. Mach
4	018-1612-54-0	1	Screw-3/8-16 x 1-1/4 Lg. Soc. Hd. Stl. Knurled Pt. Set.
5	038-0171-00-0	1	Body-Valve
6	040-1139-03-0	1	Ring-Body Seal
7	040-2090-03-0	1	Ring-Piston Seal
8	040-2140-03-0	1	Ring-Body Seal
9	042-0091-00-0	1	Spring
10	073-0041-00-0	1	Piston-Valve
11	097-0160-01-0	2	Washer-Lock
12	097-0170-00-0	1	Washer-Valve Piston
13	101-0050-00-0	1	Plate-Instruction
14	200-0020-00-0	1	Switch-Priming Valve





---

**PARTS LIST HALE TYPE K HEAT EXCHANGER  
FIGURE 6-10**

<b>ITEM NO.</b>	<b>PART NO</b>	<b>QTY</b>	<b>DESCRIPTION</b>
1	018-1406-02-0	8	Screw – 5/16-18 X 3/4 Lg. Cad. Pl. Stl. Hex Cap
2	018-1412-02-0	1	Screw – 5/16-18 X 1-1/4 Lg. Cad. Pl. Stl. Hex Cap
3	044-0670-00-0	1	Header – Heat Exchanger
4	046-5970-00-0	1	Gasket – Header
5	046-5980-00-0	2	Gasket – Connector
6	048-0510-00-0	2	Sleeve – 5/16 In. O.D. Tubing
7	082-3004-00-0	2	Connector-1/4 In. NPT Female x 5/16 O.D. Tube
8	108-0180-00-0	1	Body – Heat Exchanger
9	115-0800-01-0	*	Connector – 1-1/4 "B" Cooler
	115-0800-02-0	*	Connector – 1-1/2 "C" Cooler
	115-0800-03-0	*	Connector – 1-3/4 "D" Cooler
	115-0800-04-0	*	Connector – 2 "E" Cooler
	115-0800-05-0	*	Connector – 2-1/4 "F" Cooler
	115-0800-06-0	*	Connector – 2-1/2 "G" Cooler
10	217-0201-00-0	1	Plug – 1/4 NPT M.I.
11	507-0150-00-0	1	Coil – Heat Exchanger Cooler

\*NOTE: (2) CONNECTORS REQUIRED PER ASSEMBLY IN ANY COMBINATION

THE HALE TYPE K HEAT EXCHANGER IS AVAILABLE IN 1-1/4 TO 2-1/2 ENGINE COOLANT CONNECTIONS. THE COMPLETE HEAT EXCHANGER MODEL NUMBER IS FORMED AS FOLLOWS:

FOR EXAMPLE, A K HEAT EXCHANGER IS REQUIRED TO HAVE A 1-1/2" HEADER SIDE CONNECTION AND A 2" BODY SIDE CONNECTION. THE K HEAT EXCHANGER MODEL NUMBER WOULD BE CKE AS SHOWN.

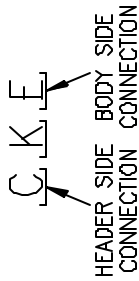

- NOTES:
- 1) ALL DIMENSIONS ARE IN INCHES & [MILLIMETERS].
  - 2) BODY (ITEM NO. 8) & HEADER (ITEM NO.3) CAN BE ROTATED IN 60° INCREMENTS FROM POSITION SHOWN.
  - 3) ENGINE COOLANT & COOLING WATER FLOW DIRECTIONS CAN BE REVERSED

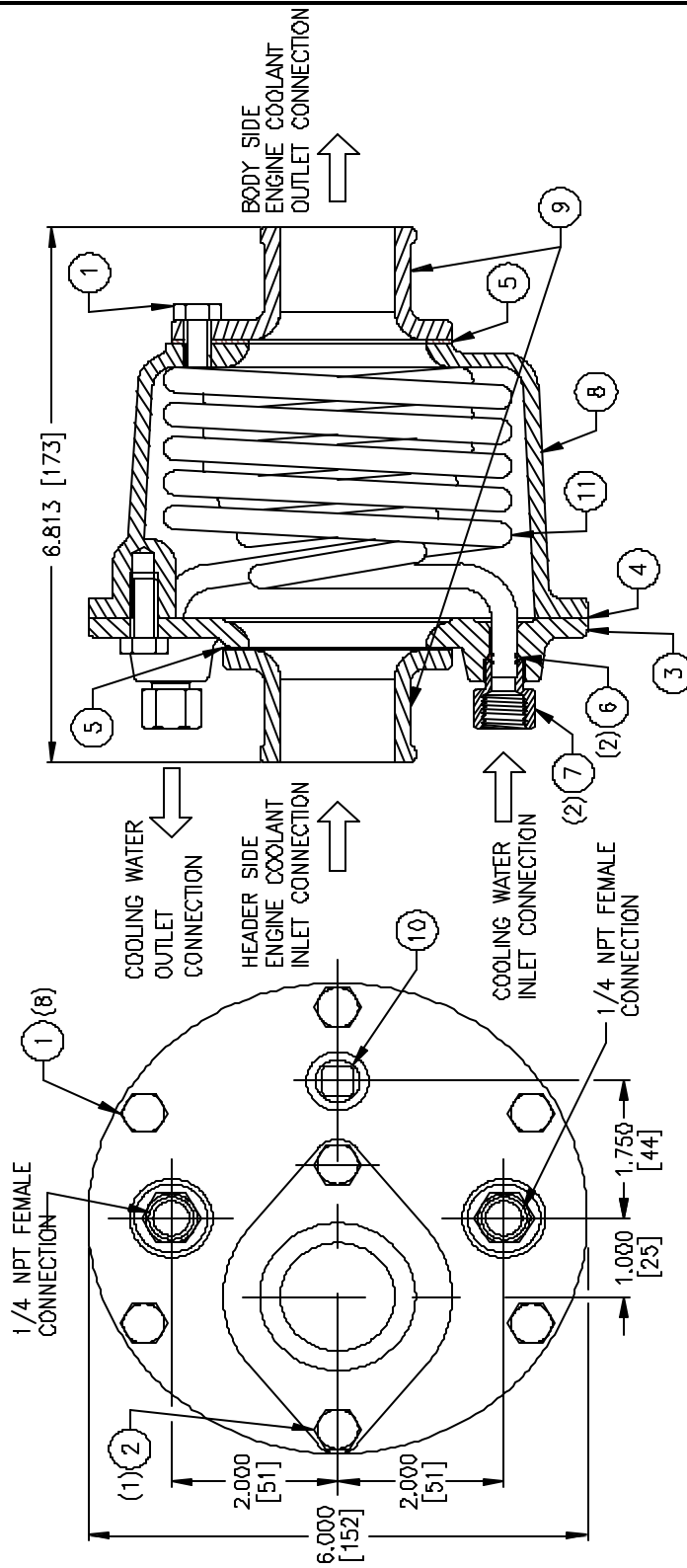

Figure 6-10. Hale Type K Series Heat Exchanger



**PARTS LIST HALE TYPE TRV/TRVM SERIES RELIEF VALVE  
FIGURE 6-11**

<b>ITEM NO.</b>	<b>PART NO</b>	<b>QTY</b>	<b>DESCRIPTION</b>
1	010-0580-00-0	1	Strainer – Inlet
2	018-1607-58-0	1	Screw – Adjusting
3	038-1251-00-0	1	Element – Temperature (120°F/49°C)
	038-1251-01-0	1	Element – Temperature (170°F/77°C)
4	038-1280-00-0	1	Body – (TRV 120) (1-1/4 NPT)
	038-1280-03-0	1	Body – (TRV170) (1-1/4 NPT)
	038-1280-01-0	1	Body – (TRVM) (ISO 228/1-G 1-1/4)
5	040-0250-07-0	2	Ring – Piston Seal
6	042-0540-00-0	1	Spring – Piston
7	064-0322-02-0	1	Pin – Spring (TRV170 Only)
8	073-0100-00-0	1	Piston
9	077-1180-20-0	1	Ring – Spring Retaining
10	077-9024-20-0	1	Ring – Element Retaining
11	217-0101-13-0	1	Plug – 1/8 NPT Soc. Hd. Brass (not used when TRV-L Kit installed)

**PARTS LIST TRV-L KIT**

12	082-0145-02-0	1	Elbow – 1/8 NPT x 1/4 FNPT Reducing Street
13	082-0146-02-0	1	Fitting – 1/8 NPT x 1/8 FNPT
14	101-1720-00-0	1	Nameplate – Test Switch and Light
15	200-0120-04-0	1	Switch – Push Button
16	200-0540-02-0	1	Bulb – Only
17	200-0540-13-0	1	Lens – Red
18	200-0540-16-0	1	Body – Indicator Light
19	200-2560-00-0	1	Switch – Foammaster
20	513-0360-01-0	1	Wire Harness

**OPTIONAL AUDIBLE ALARM FOR TRV-L KIT**

21	200-1310-00-0	1	Alarm – Audible
----	---------------	---	-----------------

**OPTIONAL FLANGE FOR MOUNTING TRV ON MIDSHIP PUMP (NOT SHOWN)**

018-1812-02-0	4	Screw – 7/16-14 x 1-1/4 Lg. Hex Hd. Zinc Pl. Stl. Cap
046-0050-00-0	1	Gasket – Flange
115-1260-00-0	1	Flange – 1-1/4 NPT



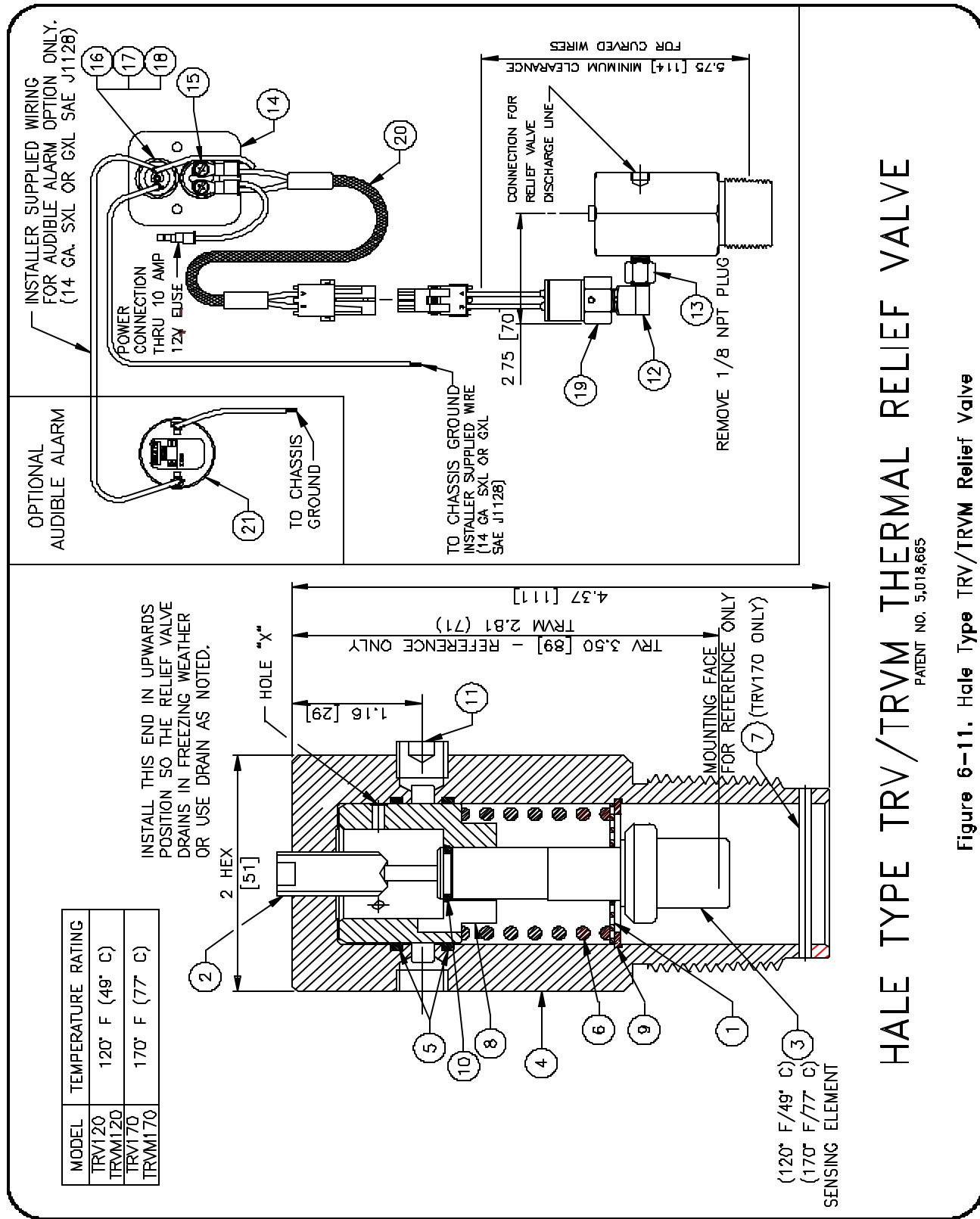

# HALE TYPE TRV/TRVM THERMAL RELIEF VALVE

PATENT NO. 5,018,665

Figure 6-11. HALE Type TRV/TRVM Relief Valve



---

**PARTS LIST HALE TYPE PG30 RELIEF VALVE  
FIGURE 6-12**

<b>ITEM NO.</b>	<b>PART NO</b>	<b>QTY</b>	<b>DESCRIPTION</b>
1	018-1104-02-0	1	Screw-#10-32 x 1/2 Lg. Hex Hd. Zinc Pl. Stl. Mach.
2	018-1110-02-0	1	Screw-#10-32 x 1 Lg. Hex Hd. Zinc Pl. Stl. Mach.
3	018-1814-02-0	8	Screw-7/16-14 x 1-1/2 Lg. Hex Hd. Zinc Pl. Stl. Cap
4	018-1816-02-0	4	Screw-7/16-14 x 1-3/4 Lg. Hex Hd. Zinc Pl. Stl. Cap
5	019-0110-00-0	1	Guard-Switch
6	038-0281-00-0	1	Body-Relief Valve
7	038-1010-01-0	1	Valve
8	040-1149-00-0	1	Ring-Cover Seal
9	040-1160-03-0	1	Ring-Valve Seal
10	040-2340-00-0	1	Ring-Piston Seal
11	042-0020-00-0	1	Spring-Valve
12	046-0050-00-0	2	Gasket-Flange
13	046-6250-00-0	1	Gasket-Cover
14	073-0190-01-0	1	Piston-Relief Valve
15	077-0620-44-0	1	Ring-Spring Retaining
16	077-0750-21-0	1	Ring-Piston Retaining
17	082-0107-02-0	1	Connector-1/8 NPT to 3/8 Tubing Compression
18	097-0160-01-0	2	Washer-#10 Zinc Pl. Stl. Lock
19	097-0250-00-0	4	Washer-Flat Zinc Pl. Stl.
20	097-0440-00-0	2	Washer-Valve Mounting
21	097-0990-00-0	1	Washer-Spring Zinc Pl. Stl.
22	110-7610-00-0	1	Nut - 9/16-18 Stamped Stl
23	110-1100-02-0	2	Nut-#10-32 Hex Zinc Pl. Stl.
24	115-0080-00-0	1	Flange-3 NPT
25	513-0421-00-0	1	Flasher Assembly
26	200-2271-00-0	1	Switch-Pilot Light
27	242-0081-00-0	1	Strap-Switch
28	544-0100-00-0	1	Cover-Relief Valve
29	242-0510-14-0	1	Strap - Flasher

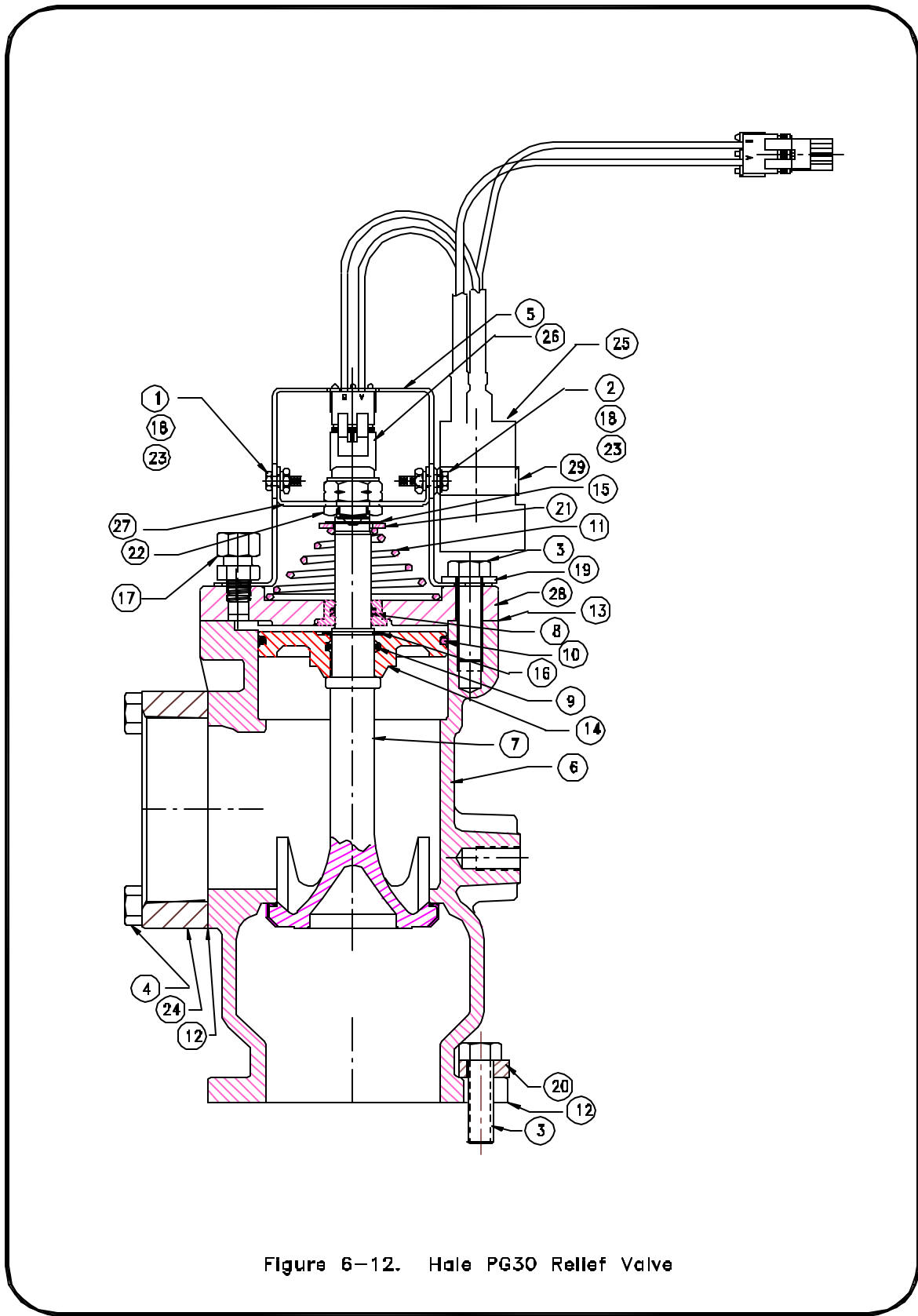

Figure 6-12. Hale PG30 Relief Valve

**PARTS LIST HALE TYPE SV SENSING VALVE  
FIGURE 6-13**

ITEM NO.	PART NO	QTY	DESCRIPTION
1	010-0080-01-0	1	Strainer-Relief Valve Control
2	018-1412-02-0	4	Screw-5/16-18 x 1-1/4 Lg. Hex Hd Zinc Pl. Stl. Cap
3	018-1820-02-0	1	Screw-7/16-14 x 2 Lg. Hex Hd. Zinc Pl. Stl. Cap
4	038-1290-00-0	1	Valve-Sensing Needle
5	038-1550-00-0	1	Valve-Check
6	042-0560-00-0	1	Spring-Sensing Valve
7	044-1220-00-0	1	Cover-Sensing Valve
8	046-0130-00-0	1	Diaphragm-Control Body
9	082-0210-02-0	1	Nipple-1/4 NPT Brass Close
10	097-0220-00-0	1	Washer-Diaphragm Support
11	242-0750-00-0	1	Clamp-Sensing Valve
12	538-1431-00-0	1	Body-Sensing Valve

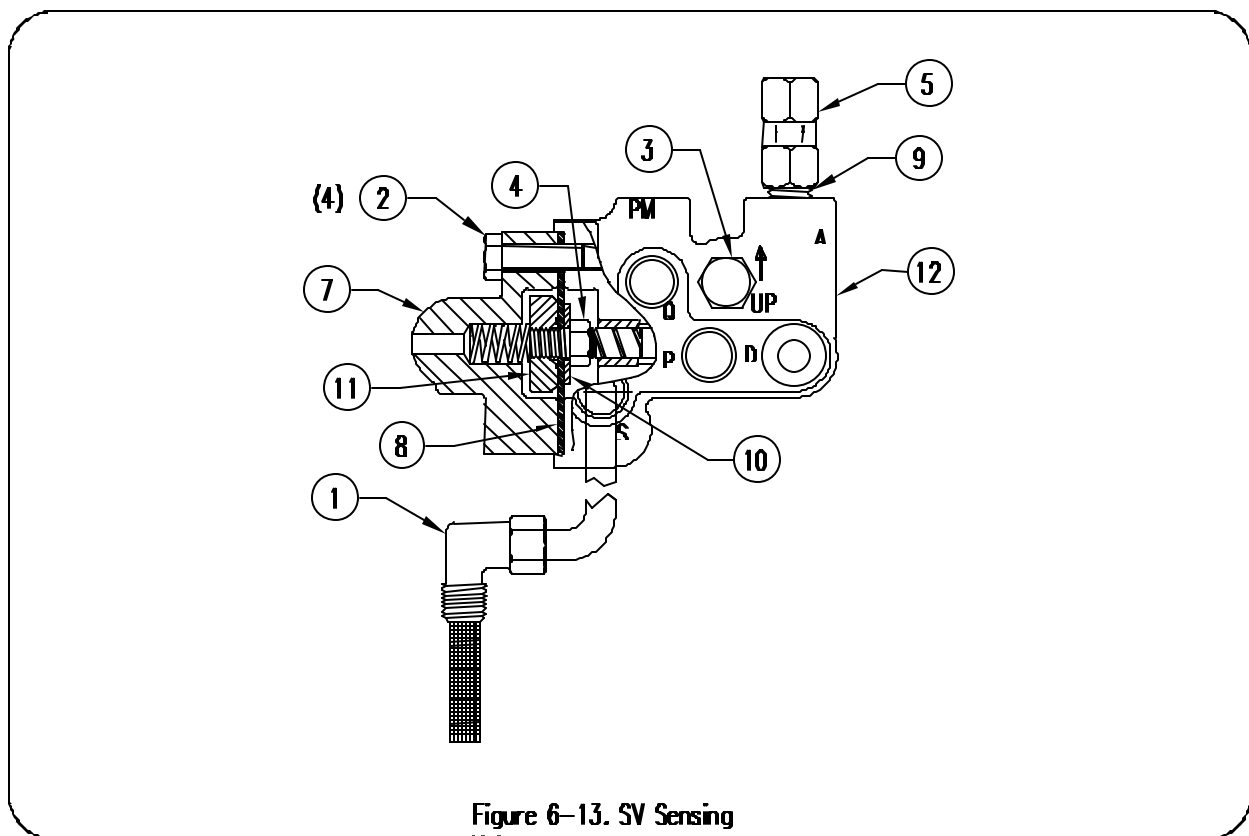

Figure 6-13. SV Sensing



**PARTS LIST HALE TYPE PM/PMD CONTROL VALVE  
FIGURE 6-14**

ITEM NO.	PART NO	QTY	DESCRIPTION
	562-0800-00-0	-	PM CONTROL VALVE (Used with QD & QG Relief Valve Systems)
	562-0081-00-0	-	PMD CONTROL VALVE (Used with TPM Relief Valve System)
1	018-1422-02-0	4	Screw-5/16-18 X 2-1/4 Lg. Hex Hd. Zinc Pl. Stl. Cap
2	038-0191-00-0	1	Valve-Control
3	041-0241-00-0	1	Stem-Adjusting
4	042-0100-00-0	1	Spring-Inside
5	042-0110-00-0	1	Spring-Outside
6	046-0130-00-0	1	Diaphragm-Control Body
7	062-0090-00-0	1	Housing-Spring
8	064-6310-00-0	1	Pin-Indicator
9	077-1120-40-0	1	Ring-Bearing Washer Retaining
10	082-0107-02-0	1	Connector-Compression 1/8 NPT To 3/8 Tubing
11	082-0206-02-0	1	Connector-Compression 1/4 NPT To 3/8 Tubing
12	097-0180-00-0	1	Washer-Bearing
13	097-0220-00-0	1	Washer-Diaphragm Support
14	097-1150-00-0	1	Washer-Sealing
15	101-0010-00-0	1	Tag-Instruction (Not Shown)
16	110-7011-00-0	1	Nut-Adjusting
17	242-0050-00-0	1	Clamp-Diaphragm
18	250-8002-00-0	1	Bearing-Thrust
	512-0070-00-0	1	Wheel-Adjusting (Assembly)
19	012-0170-00-0	1	Wheel-Adjusting
20	012-0180-00-0	1	Handle-Wheel
21	018-1214-45-0	1	Screw-1/4-20 X 1-1/2 Slotted Rd. Hd Zinc Pl. Steel Mach.
22	064-1016-01-0	1	Pin-Spring
23	110-1205-11-0	1	Nut-1/4-20 Esna Nylon Lock 300 Series Stainless
24	538-0790-00-0	1	Body-Control (Assembly)
	038-0181-00-0	1	Body-Control (Included in 538-0790-00-0)
	250-9140-00-0	1	Bearing-Pm Control (Included in 538-0790-00-0)
	519-0071-10-0	1	Indicator-PMD Control (Used on PMD Control in TPM Relief Valve System)
25	519-0071-00-0	1	Bracket-Control Valve Indicator
26	048-1121-00-0	1	Slide-Control Valve Indicator
27	097-0750-01-0	1	Washer
28	110-1008-06-0	1	Nut-Lock
29	010-0080-01-0	1	Strainer-Relief Valve Control
30	018-1205-44-0	4	Screw-1/4-20 X 5/8 Lg. Rd. Hd. Sst. Philips Head Mach.
31	101-0062-00-0	1	Plate-Instruction
	101-0062-01-0	1	Plate-Instruction (Used on PM Control in QD & QG Relief Valve Systems)
32	200-0540-03-0	1	Light-Indicator (Assembly) (Amber)
	200-0540-02-0	1	Bulb-14V, 0.24AMP, 3.4W, 2CP
	200-0540-12-0	1	Body-Indicator Light
	200-0540-15-0	1	Lens-Yellow (Amber)

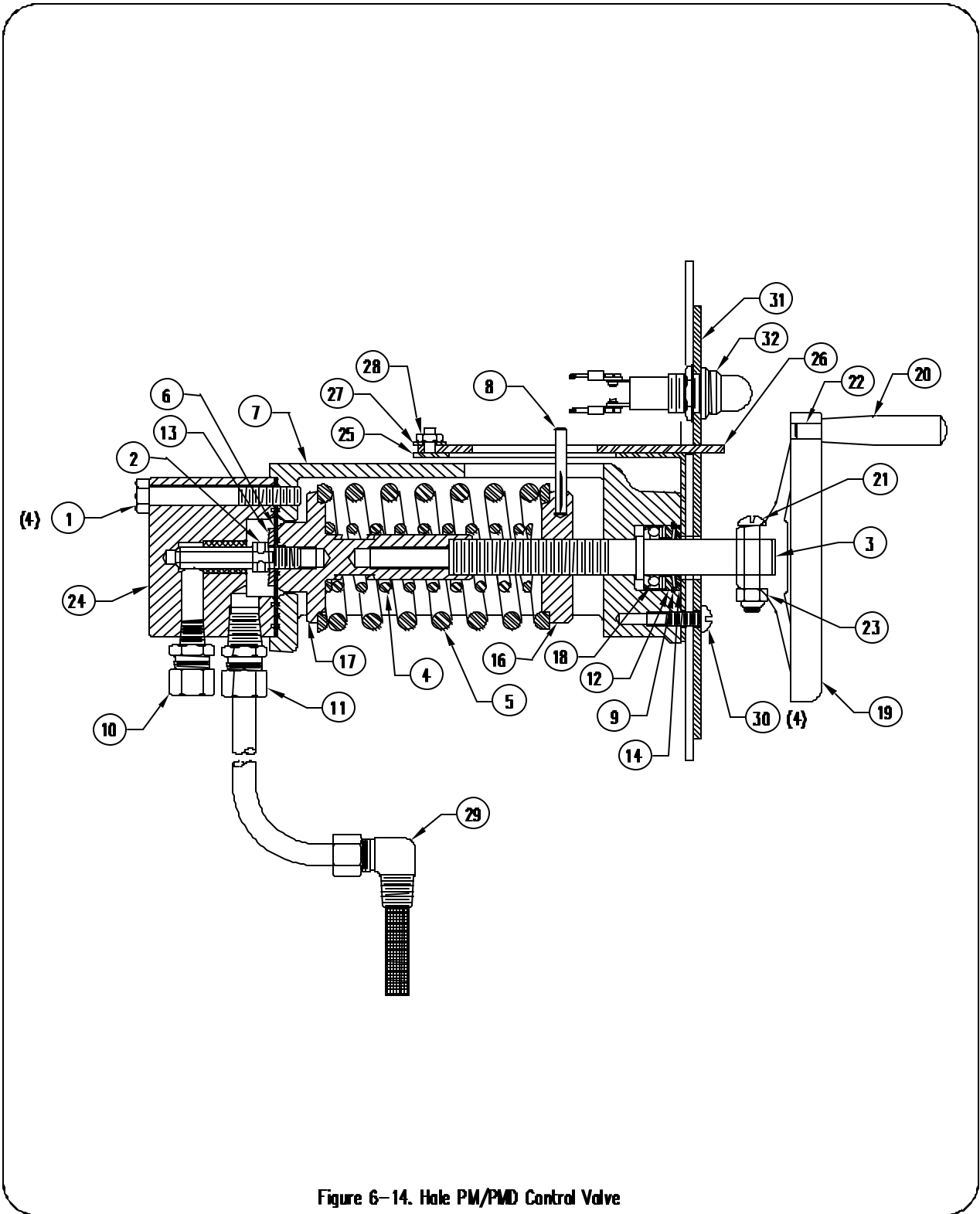

Figure 6-14. HALE PM/PMD Control Valve



---

**PARTS LIST HALE TYPE QD RELIEF VALVE  
FIGURE 6-15**

<b>ITEM NO.</b>	<b>PART NO</b>	<b>QTY</b>	<b>DESCRIPTION</b>
1	018-1104-02-0	2	Screw-#10-32 X 1/2 Lg. Hex Hd. Zinc Pl. Stl. Mach.
2	018-1822-02-0	4	Screw-7/16-14 X 2-1/4 Lg. Hex Hd. Zinc Pl. Stl. Cap
3	038-0090-00-0	1	Valve-Relief Valve
4	038-0100-00-0	1	Body-Relief Valve
5	040-1149-00-0	1	Ring-Cover Seal
6	040-1160-03-0	1	Ring-Piston Seal (Small)
7	040-1570-00-0	1	Ring-Valve Body Seal
8	040-2390-00-0	1	Ring-Piston Seal (Large)
9	040-2420-00-0	1	Ring-Valve Body Seal
10	042-0020-00-0	1	Spring-Valve
11	073-0010-00-0	1	Piston-Relief Valve
12	077-0620-44-0	1	Ring-Spring Retaining
13	077-0750-21-0	1	Ring-Piston Retaining
14	082-0206-02-0	1	Connector-Compression 1/4 NPT to 3/8 Tubing
15	097-0160-01-0	2	Washer-#10 Zinc Pl. Stl. Lock
16	097-0990-00-0	1	Washer
17	110-1100-02-0	2	Nut-#10-32 Zinc Pl. Stl. Hex
18	200-2450-00-0	1	Switch-Indicator Light
19	242-0011-00-0	1	Bracket-Switch
20	242-0081-00-0	1	Strap-Switch
21	544-0010-00-0	1	Valve-Relief Valve (Assembly)
	044-0120-00-0	1	Cover-Relief Valve
	048-0050-00-0	1	Sleeve-Relief Valve Cover
22	110-7610-00-0	1	Nut - 9/16-18 Stamped Stl.
23	064-1040-02-0	1	Pin

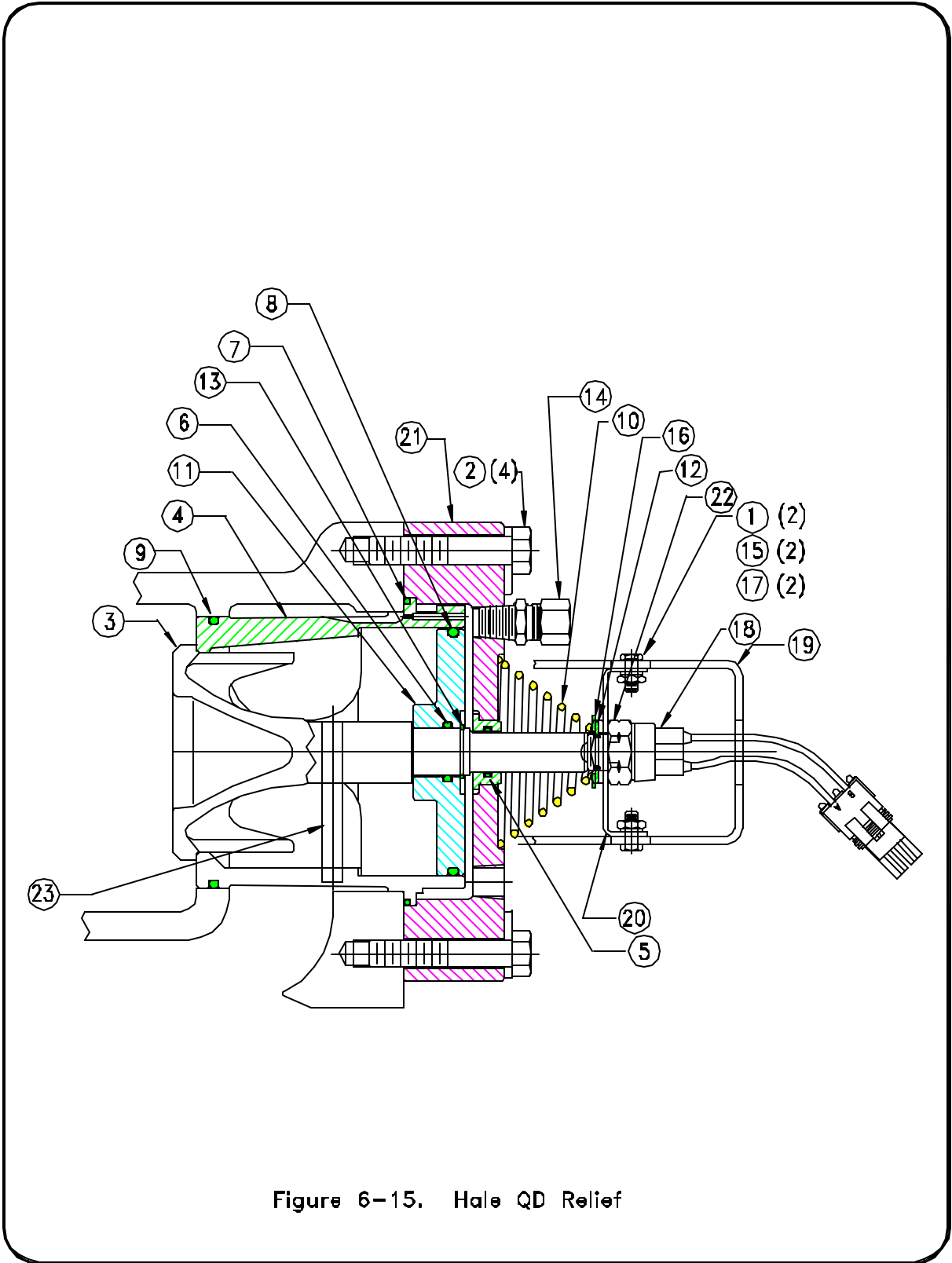
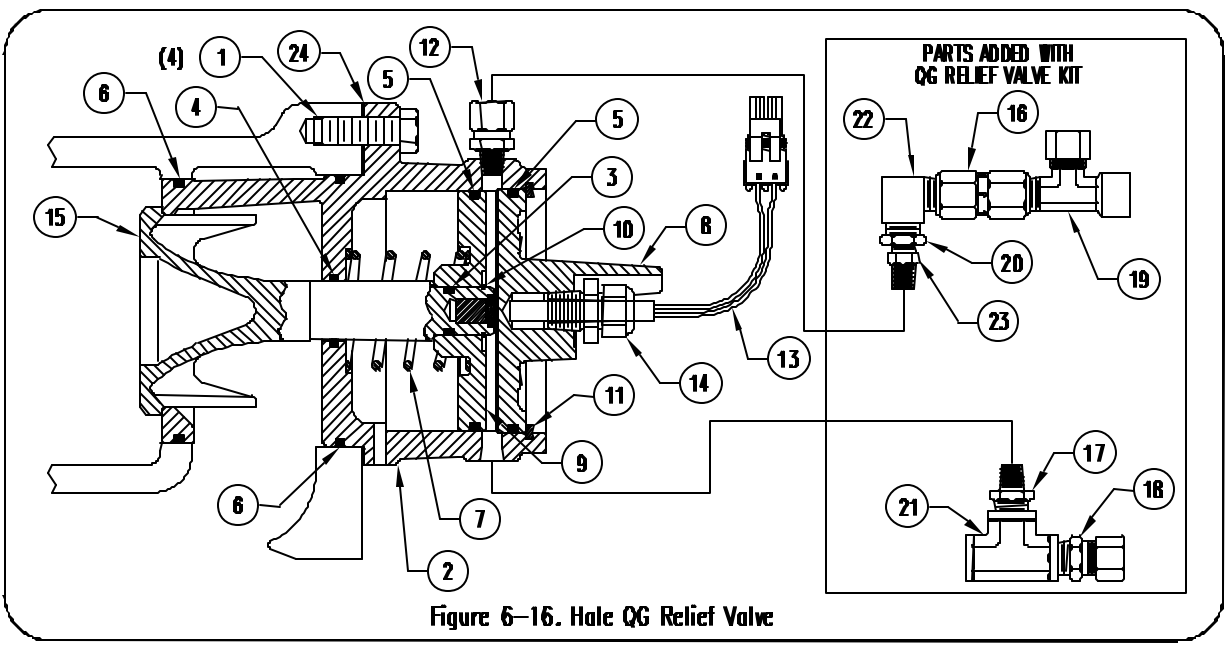

Figure 6-15. Hale QD Relief



**PARTS LIST HALE TYPE QG RELIEF VALVE  
FIGURE 6-16**

ITEM NO.	PART NO	QTY	DESCRIPTION
1	018-1812-02-0	4	Screw-7/16-14 x 1-1/4 Lg. Hex Hd. Zinc. Pl. Stl. Cap
2	038-0101-00-0	1	Body-Relief Valve
3	040-1130-03-0	1	Ring-Piston Seal
4	040-2130-03-0	2	Ring-Relief Valve Seal
5	040-2390-00-0	2	Ring-Piston & Cover Seal
6	040-2420-00-0	1	Ring-Valve Body Seal
7	042-0550-00-0	1	Spring-Valve
8	044-0122-00-0	1	Cover-Relief Valve
9	073-0011-00-0	1	Piston-Relief Valve
10	077-0750-21-0	1	Ring-Piston Retaining
11	077-3930-00-0	1	Ring-Cover Retaining
12	082-0107-02-0	1	Connector-Compression 1/8 NPT to 3/8 Tubing
13	200-2262-00-0	1	Switch-Proximity
14	200-2650-00-0	1	Collet Fitting
15	538-1400-00-0	1	Valve-Relief Valve
16	038-1550-00-0	1	Valve-Check
17	082-0137-02-0	1	Nipple-1/8 NPT Hex
18	082-0206-02-0	1	Fitting-1/4 NPT x 3/8 Tube
19	082-0207-02-0	1	Tee-1/4 NPT x 1/4 FNPT x 3/8 tube compression
20	082-0214-02-0	1	Bushing-1/4 NPT x 1/8 NPT Brass
21	082-0230-02-0	1	Tee-1/4 x 1/4 x 1/8 NPT Brass
22	082-0257-02-0	1	Elbow-1/4 NPT Brass Service
23	082-3051-00-0	1	Orifice-QG Relief Valve
24	046-0080-00-0	1	Gasket-Relief Valve Body



**PARTS LIST HALE ANTI-CORROSION ANODE  
FIGURE 6-17**

ITEM NO.	PART NO	QTY	DESCRIPTION
1	529-0080-00-0	1	Kit-Anode
2	029-0510-00-0	1	Anode-Zinc (Assembly)
3	115-1260-00-0	1	Flange-Hale 115
4	046-0050-00-0	1	Gasket-Hale 115 Series
5	018-1812-02-0	4	Screw-7/16-14UNC x 1-1/4 Hex Hd. Cap

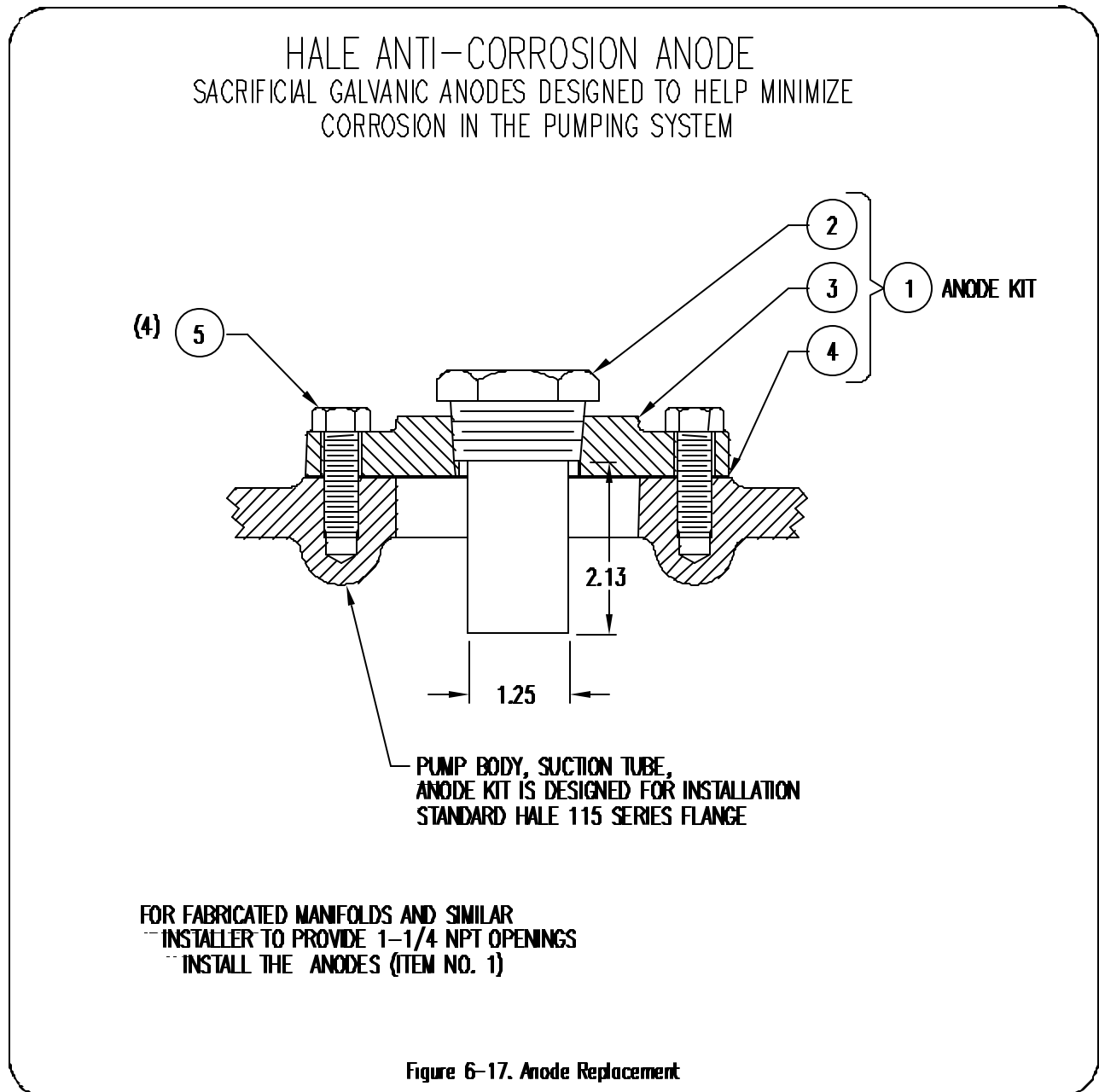



**PARTS LIST HALE TYPE 30BPF TANK SUCTION VALVE  
(LESS CHECK VALVE)  
FIGURE 6-18  
(ASSEMBLY PART NO. 538-0132-00-0)**

ITEM NO.	PART NO	QTY	DESCRIPTION
1	012-0080-00-0	1	Handle-Valve
2	018-1204-61-0	1	Screw-1/4-20 x 1/2 Flt Pt. Nylon Lock Zinc Pl. Stl. Set
3	018-1810-02-0	6	Screw-7/16-14 x 1 Lg. Hex Hd. Zinc Pl. Stl. Cap
4	018-2012-02-0	4	Screw-1/2-13 x 1-1/4 Lg. Hex Hd. Stl. Zinc Pl. Cap
5	018-8040-00-0	2	Stud-Body
6	039-0030-00-0	1	Ball-Valve
7	040-2109-00-0	2	Ring-Stem Seal
8	040-3390-01-0	1	Ring-Seat Seal
9	046-0060-00-0	1	Gasket-Body
10	064-1032-11-0	1	Pin-Handle
11	101-0480-00-0	1	Tag-Instruction
12	110-1800-02-0	1	Nut-7/16-14 Zinc Pl. Steel Hex
13	142-0530-00-0	1	Ring-Cover Seal
14	276-0020-00-0	1	Seat-Valve
15	538-1070-00-0	1	Body-Valve (Assembly)
16	038-0050-01-0	1	Body-Valve
17	040-0240-00-0	1	Ring-Seal
18	250-9400-00-0	1	Bearing-Valve Body
19	544-0110-00-0	1	Cover-Valve (Assembly)
20	044-0060-01-0	1	Cover-Valve
21	250-9400-00-0	1	Bearing-Valve Cover

**TANK SUCTION CHECK VALVE**

22	038-0120-00-0	1	Valve-Check (Bronze) (Optional)
----	---------------	---	---------------------------------

When the 038-0120-00-0 check valve is used with a 3" or 4" NPT tank connection flange, furnish (1) 115-0130-00-0 check valve flange and (1) 046-0060-00-0 additional gasket.  
A 4" NPT flange is not available on the Q series pump.

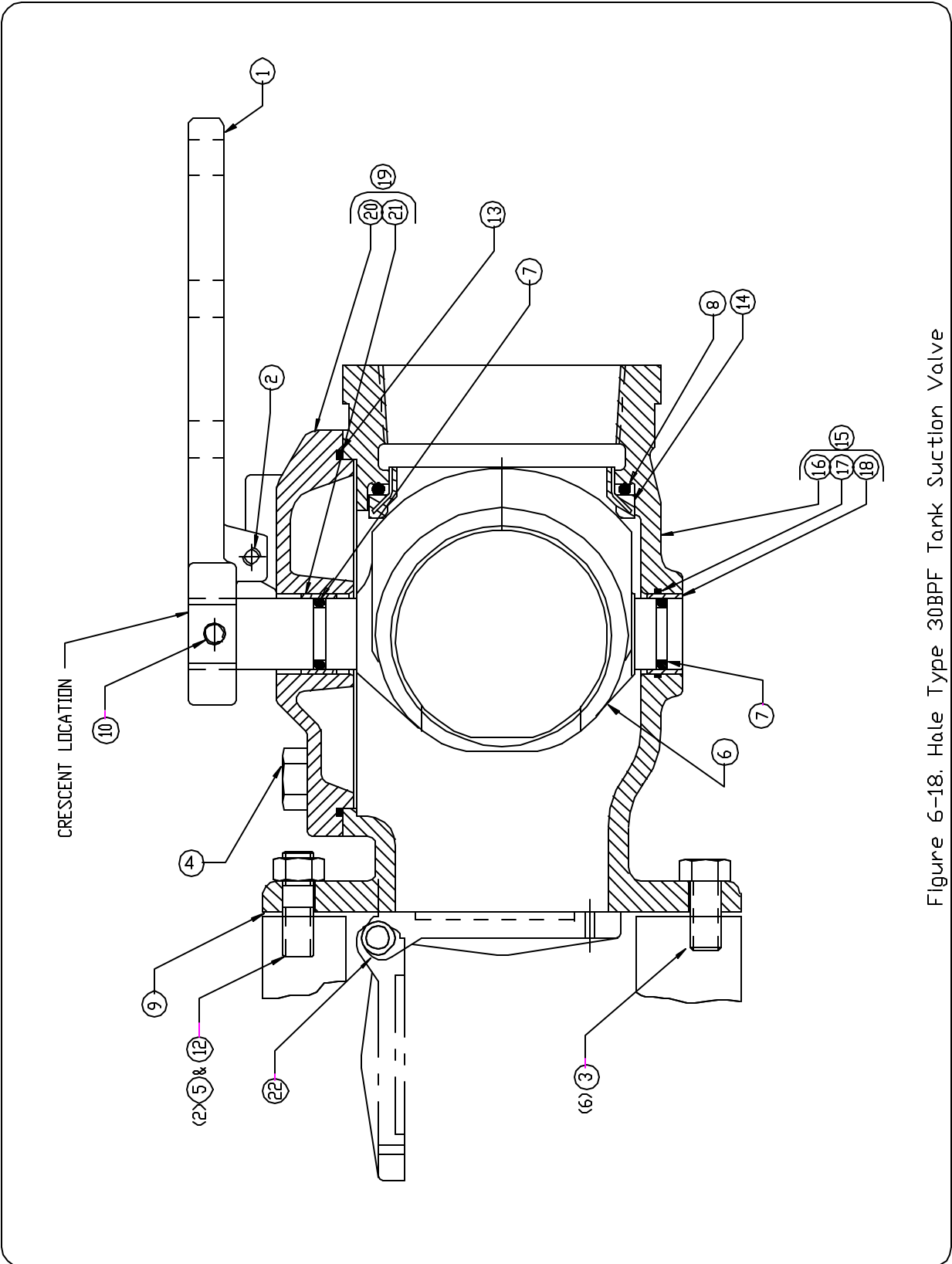

Figure 6-18. Hale Type 30BPF Tank Suction Valve



**PARTS LIST HALE TYPE 40BD SERIES VALVE LINE**  
**40BD MANUAL CONTROL VALVE**  
**40BD HANDLE CONTROL VALVE**  
**40BD ELECTRIC CONTROL VALVE**  
**STANDARD PARTS**  
**FIGURE 6-19**

ITEM NO.	PART NO	QTY	DESCRIPTION
	538-1680-01-0	1	Valve-40BD Electric Control
	538-1680-00-0	1	Valve-40BDS Manual Control
	538-1680-02-0	1	Valve-40BDS Handle Control
1	018-1810-02-0	8	Screw-7/16-14 X 1 In Lg. Hex. Hd.
2	038-1900-00-0	1	Body-Valve
◆ 3	039-0280-00-0	1	Valve-Ball
• 4	040-1500-00-0	2	Seal-Collar
• 5	040-2140-03-0	2	Seal-Stem
• 6	040-3480-01-0	1	Seal-Valve Seat
• 7	040-3620-00-0	1	Seal-Spacer
• 8	276-0270-00-0	1	Seat-Valve
9	159-1530-00-0	1	Seat-Spacer
◆ 10	548-0040-00-0	1	Collar-Bottom (Assembly)
◆ 11	548-0050-00-0	1	Collar-Top (Assembly)
	048-1360-00-0	1	Collar-Top
	040-0290-00-0	1	Seal-Bearing
	250-9560-00-0	1	Bearing

- Items Included in Valve Seal Kit (546-1940-01-0) and Valve Rebuild Kit (546-1940-02-0).
- ◆ Additional Items included in Valve Rebuild Kit (546-1940-02-0).

**40BD VALVE SEAL KIT (546-1940-01-0)**

**40BD VALVE REBUILD KIT (546-1940-02-0)**

040-1500-00-0	2	Seal-Collar
040-2140-00-0	2	Seal-Stem
040-3480-01-0	1	Seal-Valve Seat
040-3620-00-0	1	Seal-Spacer
276-0270-00-0	1	Seal-Valve
046-0060-00-0	1	Gasket
040-2620-00-0	2	Seal-Connection
046-0050-00-0	2	Gasket

039-0280-00-0	1	Valve-Ball
040-1500-00-0	2	Seal-Collar
040-2140-03-0	2	Seal-Stem
040-3480-01-0	1	Seal-Valve Seat
040-3620-00-0	1	Seal-Spacer
276-0270-00-0	1	Seat-Valve
046-0060-00-0	1	Gasket
040-2620-00-0	2	Seal-Connection
046-0050-00-0	2	Gasket
548-0040-00-0	1	Assembly-Bottom Collar
548-0050-00-0	1	Assembly-Top Collar

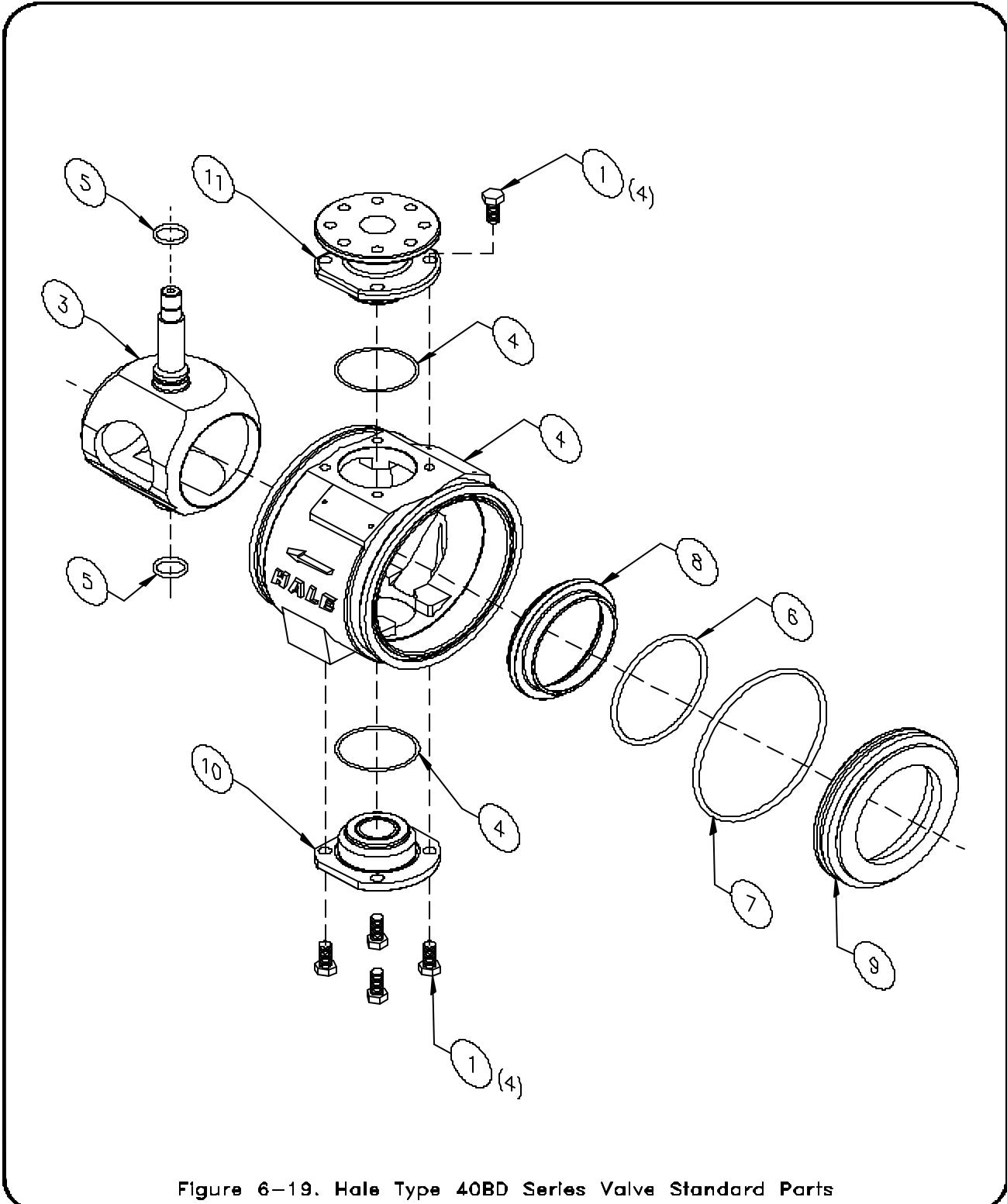

Figure 6-19. HALE Type 40BD Series Valve Standard Parts



**PARTS LIST HALE TYPE 40BDS SERIES VALVE LINE**  
**40BD MANUAL CONTROL VALVE**  
**40BD HANDLE CONTROL VALVE**  
**40BD ELECTRIC CONTROL VALVE**  
**OPTIONAL PARTS**  
**FIGURE 6-20**

**ITEM NO. PART NO QTY DESCRIPTION**

---

**MANUAL GEAR OPERATOR ASSEMBLY**

1	531-0190-00-0	1	Operator-40BD Manual Gear with Remote Placard
	531-0160-00-0	1	Actuator-Manual Gear
	008-0790-00-0	2	Switch-Cap
	097-0140-01-0	2	Washer-3/8 Lock
	200-2450-00-0	2	Switch-Shift
	064-6600-00-0	2	Pin
	018-1607-02-0	4	Screw-3/8-16 x 7/8 Lg.
	097-0680-01-0	4	Washer-3/8
	018-0803-29-0	4	Screw-#8-32 x 3/8 Lg.

**ELECTRIC GEAR OPERATOR ASSEMBLY**

2	531-0180-00-0	1	Operator-40BD Electric Gear
	531-0150-00-0	1	Actuator-Electric Gear
	200-2450-00-0	2	Switch-Shift
	008-0790-00-0	2	Switch-Cap
	064-6600-00-0	2	Pin
	110-1601-02-0	2	Nut-3/8-16
	044-1480-00-0	1	Cover-Motor
	018-0604-45-0	4	Screw-#6-32 x 1/2 Lg.
	200-1240-00-0	1	Breaker-Circuit
	048-1080-01-0	1	Pad-Breaker Mounting
	013-1360-00-0	1	Wire-White
	200-1250-00-0	1	Motor-Gear
	018-0604-08-0	4	Screw-#6-32 x 1/2 Lg. Soc. Hd.
	218-0608-08-0	4	Screw-M6-1 x 16 Soc. Hd.
	064-6350-00-0	1	Pin-Drive
	007-3330-00-0	1	Adapter-Motor
	018-1607-02-0	4	Screw-3/8-16 x 7/8 Lg.
	097-0680-01-0	4	Washer-3/8
	018-0803-29-0	4	Screw-#8-32 x 3/8 Lg.
	513-0270-05-0	1	Harness-Gearmotor Wiring



**PARTS LIST HALE TYPE 40BDS SERIES VALVE LINE**  
**40BD MANUAL CONTROL VALVE**  
**40BD HANDLE CONTROL VALVE**  
**40BD ELECTRIC CONTROL VALVE**  
**OPTIONAL PARTS (CONTINUED)**  
**FIGURE 6-20**

<b>ITEM NO.</b>	<b>PART NO</b>	<b>QTY</b>	<b>DESCRIPTION</b>
-----------------	----------------	------------	--------------------

**HANDLE ASSEMBLY**

3	512-0480-00-0	1	Assembly-40BDS Handle
	005-1230-00-0	1	Plate-Stop
	012-1470-00-0	1	Handle-Valve
	018-1404-02-0	1	Screw-5/16-18 X 1/2 Lg. Hex Hd. Zinc Pl. Stl. Cap
	018-2010-02-0	3	Screw-1/2-13 X 1 Lg. Hex Hd. Zinc Pl. Stl. Cap
	097-0580-00-0	3	Washer-1/2 Lock
	097-1850-00-0	1	Washer-Handle
	077-0870-04-0	1	E-Ring-Handle

**CONNECTOR ASSEMBLIES**

4	544-0250-00-0	1	Assembly-5" NST Valve With RV
	044-1700-00-0	1	Connector-5" NST Valve With RV (Short)
	044-1700-10-0	1	Connector-5" NST Valve With RV (Long)
	018-1812-02-0	4	Screw-7/16-14 X 1-1/4 Lg.
	538-1550-00-0	1	Valve-Relief
	101-1560-00-0	1	Tag-Relief Valve Caution
	046-0060-00-0	1	Gasket
5	544-0250-01-0	1	Assembly-5" NST Valve Connector
	044-1700-01-0	1	Connector-5" NST Valve (Short)
	044-1700-11-0	1	Connector-5" NST Valve (Long)
6	544-0250-02-0	1	Assembly-5" Vic/4" NPT Connector
	044-1680-00-0	1	Connector-5" Vic/4" NPT
7	544-0250-03-0	1	Assembly-4" Vic Connector
	044-1690-00-0	1	Connector-4" Vic

Each of the above connector assemblies include the following:

8	040-2620-00-0	1	Seal-Connection
9	217-4010-00-0	1	Cap-Thread
10	242-1000-00-0	1	Clamp-V-Band





---

**PARTS LIST HALE TYPE 40BDS SERIES VALVE LINE**  
**40BD MANUAL CONTROL VALVE**  
**40BD HANDLE CONTROL VALVE**  
**40BD ELECTRIC CONTROL VALVE**  
**OPTIONAL PARTS (CONTINUED)**  
**FIGURE 6-20**

<b>ITEM NO.</b>	<b>PART NO</b>	<b>QTY</b>	<b>DESCRIPTION</b>
-----------------	----------------	------------	--------------------

---

**MOUNT ASSEMBLIES**

11	544-0260-00-0	1	Assembly-Straight 8-Bolt Mount
	044-1650-00-0	1	8-Bolt Mount-Straight
12	544-0260-01-0	1	Assembly-3.5° 8-Bolt Mount
	044-1660-00-0	1	8-Bolt Mount-3.5°
	018-1810-91-0	8	Screw-7/16-14 X 1 Lg.
	046-0060-00-0	1	Gasket
13	544-0260-02-0	1	Assembly-Straight 4-Bolt Mount
	044-1670-00-0	1	4-Bolt Mount-Straight
	018-1810-91-0	4	Screw-7/16-14 X 1 Lg.
	046-0050-00-0	1	Gasket

Each of the above connector assemblies include the following:



**PARTS LIST HALE TYPE 40BD SERIES VALVE  
LOOSE PART KITS  
FIGURE 6-20**

**ITEM NO. PART NO QTY DESCRIPTION**

---

**MANUAL 40BD VALVE LOOSE PARTS KIT (546-1930-00-0)**

14	513-0410-01-0	1	Assembly- Remote Bushing Placard
	037-2180-00-0	1	Shaft-Remote Placard
	250-9570-00-0	1	Bearing-Placard
	040-0220-00-0	1	O-Ring-Placard
	048-1380-00-0	1	Sleeve-Placard Bushing
	088-0270-00-0	1	Joint-Universal
	018-1014-29-0	1	Screw-#10-24 X 1-1/2 In. Lg. Hex. Hd.
	097-1350-00-0	1	Washer-#10 External Tooth
	110-1000-02-0	1	Nut-#10-24 Hex
15	512-0070-00-0	1	Assembly-Handwheel
16	513-0410-00-0	1	Assembly-Manual Valve Panel Placard Harness
	101-1770-00-0	1	Placard-Manual Valve
	513-0370-00-0	1	Placard-Side Wire Harness (Manual Valve)
	200-0540-02-0	3	Bulb
	200-0540-13-0	1	Lens-Red
	200-0540-14-0	1	Lens-Green
	200-0540-15-0	1	Lens-Amber
	200-0540-16-0	3	Body-Indicator Light
	018-1205-44-0	4	Screw-1/4-20 x 5/8 Lg.
	110-1200-02-0	4	Nut-1/4-20
17	513-0430-00-0	1	Assembly-Manual Relay Harness
	513-0370-01-0	1	Harness-Gear Actuator Side (Manual Valve)
	200-2640-00-0	2	Relay
18	513-0270-04-0	1	Harness-Power
	088-0270-00-0	1	Joint-Universal
	018-1014-29-0	3	Screw-#10-24 X 1-1/2 In. Lg. Hex. Hd.
	110-1004-06-0	3	Nut-#10-24 Lock
	101-0850-54-0	1	Instructions-Installation

**ELECTRIC 40BD VALVE LOOSE PARTS KIT (546-1930-01-0)**

19	513-0390-00-0	1	Assembly- Electric Placard
	101-1770-01-0	1	Placard-Electrical
	513-0370-02-0	1	Harness-Placard Side (Electric Valve)
	200-0540-02-0	3	Bulb
	200-0540-13-0	1	Lens-Red
	200-0540-14-0	1	Lens-Green
	200-0540-15-0	1	Lens-Amber
	200-0540-16-0	3	Body-Indicator Light
	200-1220-00-0	1	Switch-Momentary Toggle
	018-1205-44-0	4	Screw-1/4-20 x 5/8 Lg.



---

**PARTS LIST HALE TYPE 40BDS SERIES VALVE LINE  
LOOSE PART KITS FIGURE 6-20 (CONTINUED)**

**ITEM NO. PART NO QTY DESCRIPTION**

---

**ELECTRIC 40BD VALVE LOOSE PARTS KIT (546-1930-01-0) (CONTINUED)**

	110-1200-02-0	4	Nut-1/4-20
20	513-0430-01-0	1	Harness-Electrical Relay (Assembly)
	513-0370-03-0	1	Harness-Gear Actuator Side (Electric Valve)
	200-2640-00-0	2	Relay
18	513-0270-04-0	1	Harness-Power
19	012-1420-00-0	1	Handle-Override
	018-1212-61-0	1	Screw-1/4-20 x 1-1/4 In. Lg.
	101-0850-54-0	1	Instructions-Installation

**VALVE OVERRIDE EXTENSION KIT (546-1950-00-0)**

	101-1770-02-0	1	Placard-Manual Override
	018-1205-44-0	4	Screw-1/4-20 x 5/8 Lg.
	110-1200-02-0	4	Nut-1/4-20
	041-0570-00-0	1	Shaft-Valve Gear Operator Extension
	018-1212-02-0	1	Screw-1/4-20 x 5/8 In. Lg. Hex Hd.
	110-1206-02-0	1	Nut-1/4-20 Lock

**40BD REMOTE OVERRIDE PLACARD KIT (546-1950-01-0)**

	513-0400-00-0	1	Assembly-Electric Override Placard Remote Bushing
	088-0270-00-0	1	Joint-Universal
	018-1014-27-0	3	Screw-#10-24 X 1-1/2 In. Lg. Hex. Hd.
	110-0114-06-0	3	Nut-#10-24 Lock
	101-0850-54-0	1	Instructions-Installation

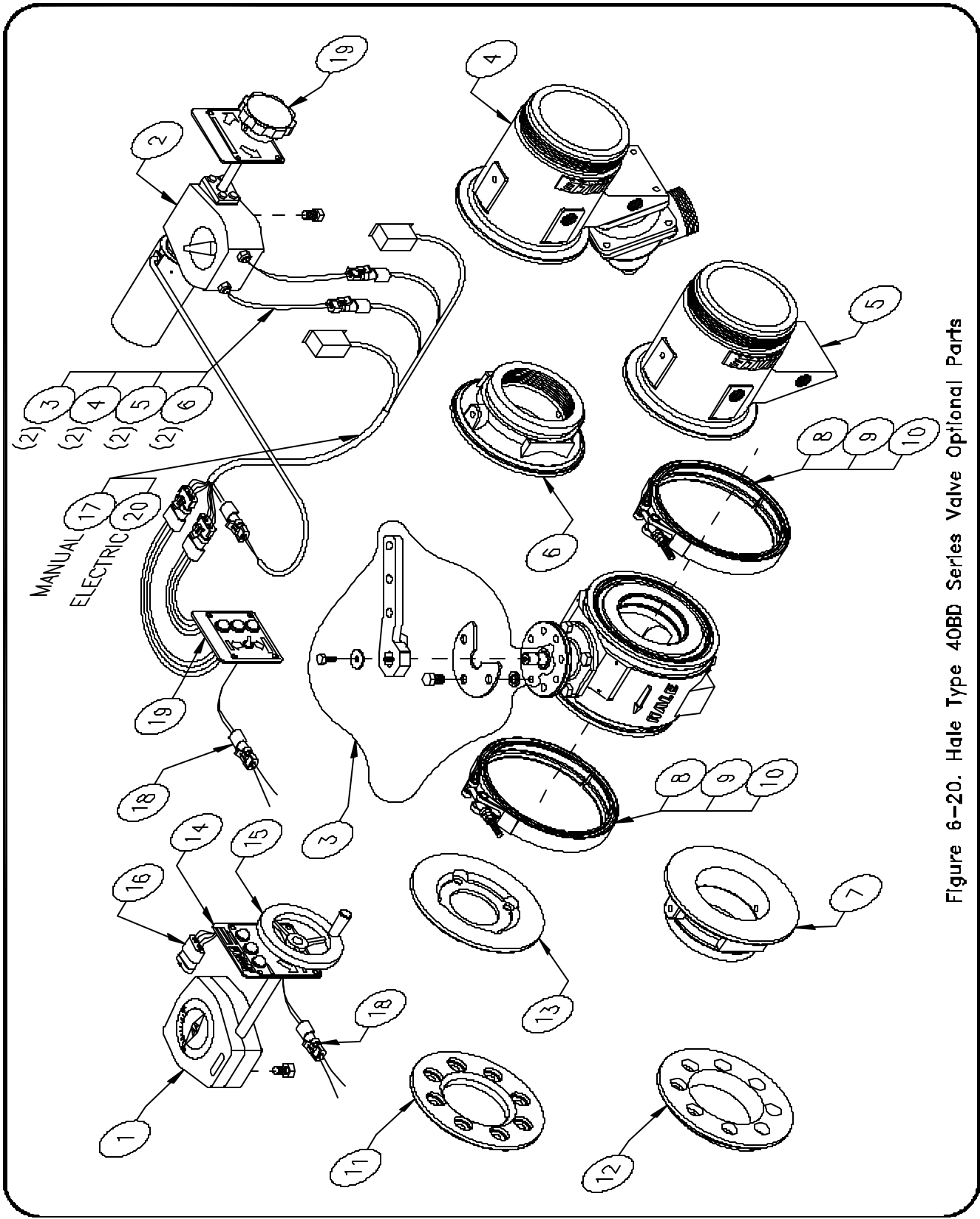

Figure 6-20. Hale Type 40BD Series Valve Optional Parts



### PARTS LIST HALE TYPE HD DRAIN VALVE

#### FIGURE 6-21

ITEM NO.	PART NO	QTY	DESCRIPTION
----------	---------	-----	-------------

1	012-0010-00-0	1	Knob-Valve
2	038-0380-00-0	1	Body-Valve
3	040-1140-03-0	2	Ring-Piston Seal
4	073-0180-00-0	1	Piston-Valve
5	077-0810-10-0	1	Ring-Piston Retaining

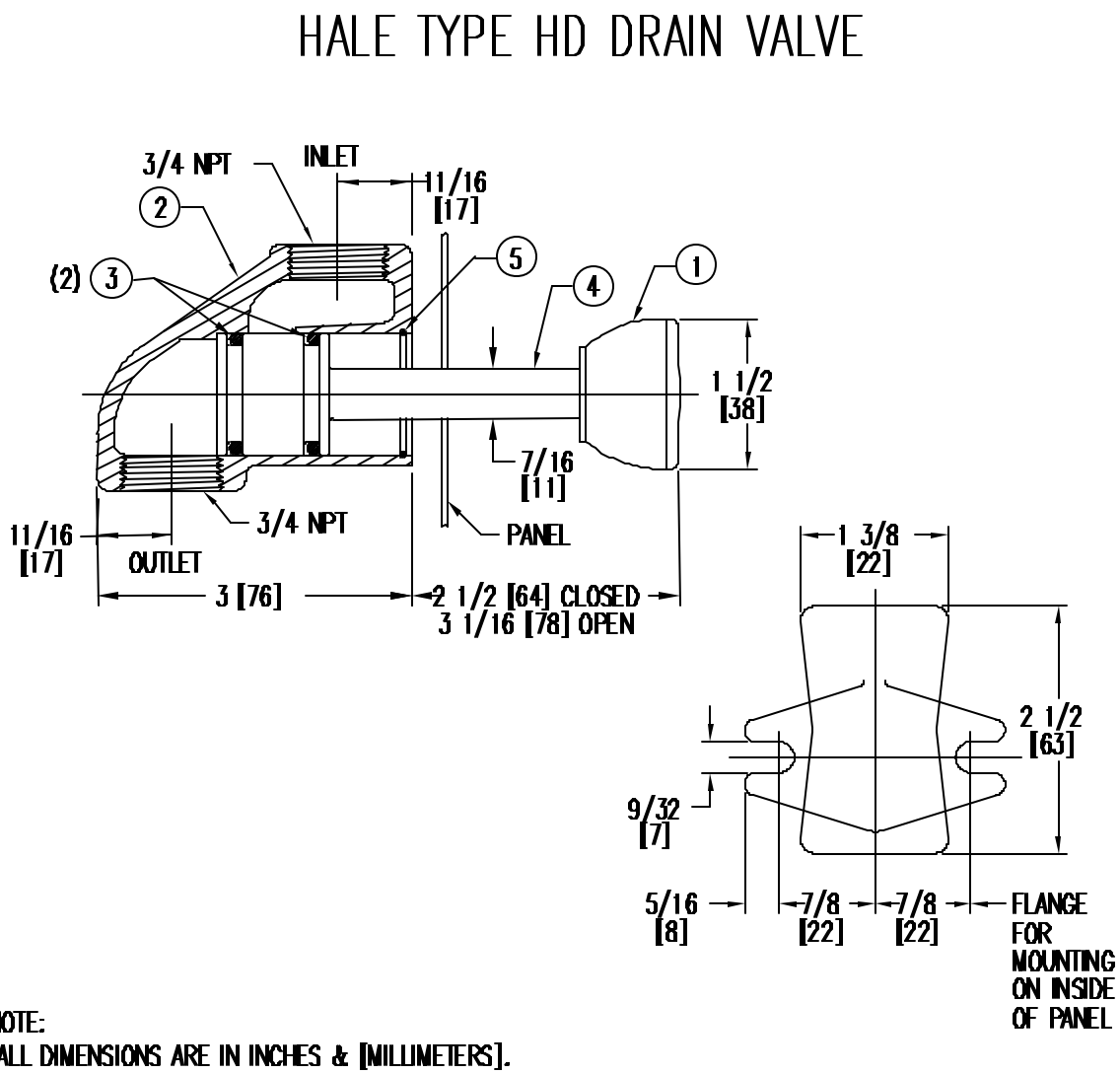
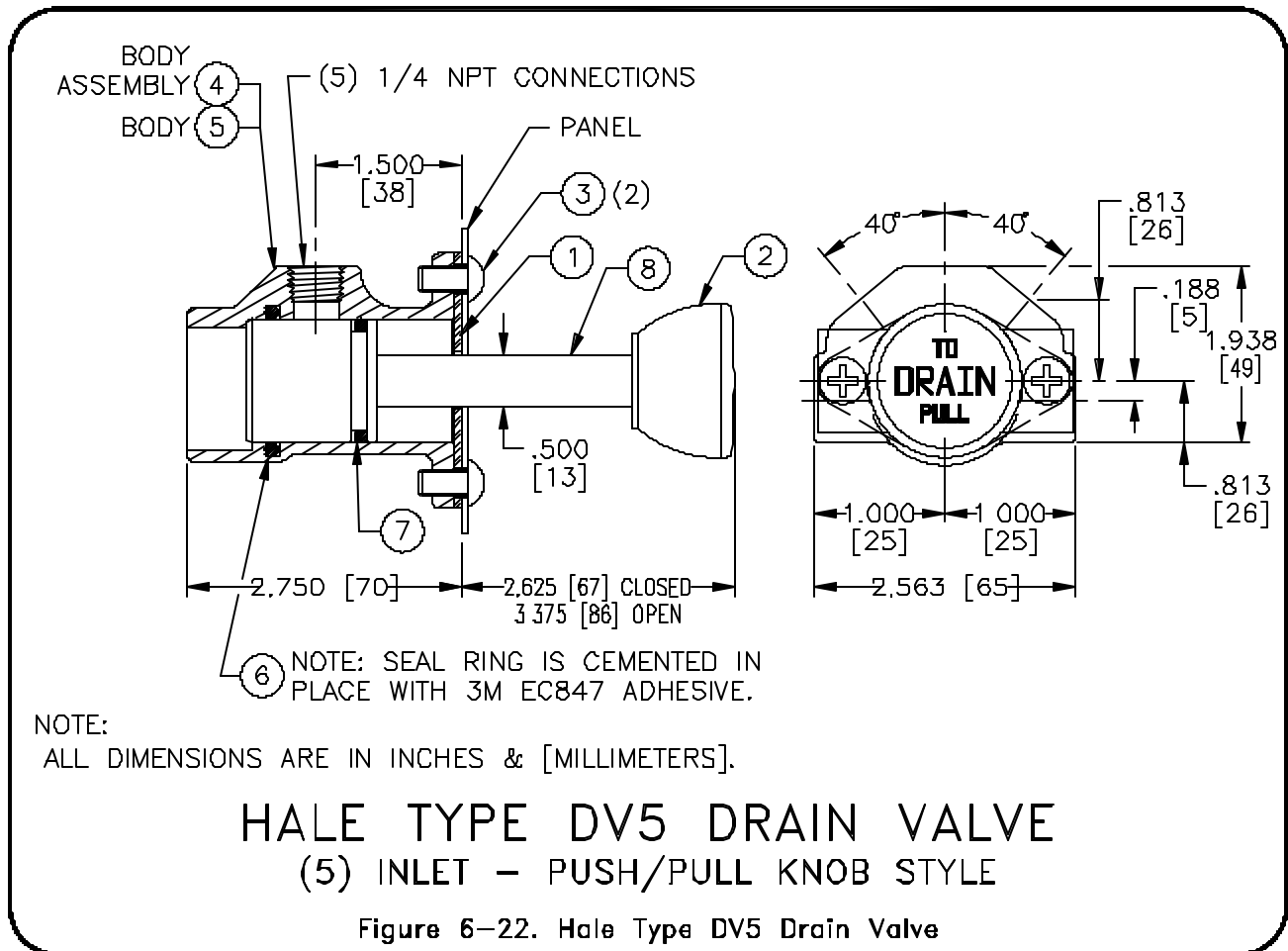

Figure 6-21. HALE Type HD Drain Valve

**PARTS LIST HALE TYPE DV5 DRAIN VALVE  
FIGURE 6-22**

ITEM NO.	PART NO	QTY	DESCRIPTION
1	005-0260-00-0	1	Plate-Piston Stop
2	012-0010-00-0	1	Knob-Valve Piston
3	018-1205-44-0	2	Screw-1/4-20 x 5/8 Lg. Rd. Hd. SST P.H. Mach.
4	038-1110-00-0	1	Body-Drain Valve (Assembly)
5	038-1110-01-0	1	Body-Drain Valve
6	040-2180-00-0	1	Ring-Body Seal
7	040-2130-03-0	1	Ring-Piston Seal
8	073-0200-00-0	1	Piston-Valve Handle





---

**PARTS LIST HALE TYPE DV7 DRAIN VALVE  
FIGURE 6-23**

<b>ITEM NO.</b>	<b>PART NO</b>	<b>QTY</b>	<b>DESCRIPTION</b>
1	021-5000-00-0	1	Universal Joint
2	038-5031-00-0	1	Body-Drain Valve
3	046-7020-00-0	1	Seat-Drain Valve
4	064-0414-02-0	2	Pin-1/8 Dia. X 7/8 Lg. SST
5	077-9020-20-0	2	Ring-Retaining
6	082-5030-00-0	1	Fitting-Grease
7	097-5051-00-0	1	Washer-Seat Retaining
8	097-5060-00-0	2	Washer-Thrust
9	012-5071-00-0	1	Knob-Drain Valve (With 10-32NF X 3/8 Lg. Dog Point SST Setscrew)
10	041-5001-00-0	1	Stem-Drain Valve
	538-1650-00-0	-	Assembly-Hale Type DV7 Drain Valve (Without Knob, Item No. 9)
	538-1650-01-0	-	Assembly-Hale Type DV7 Drain Valve (With Universal Joint, Item No.1, and Knob, Item No. 9)
	538-1650-02-0	-	Assembly-Hale Type DV7 Drain Valve (With Knob, Item No. 9)

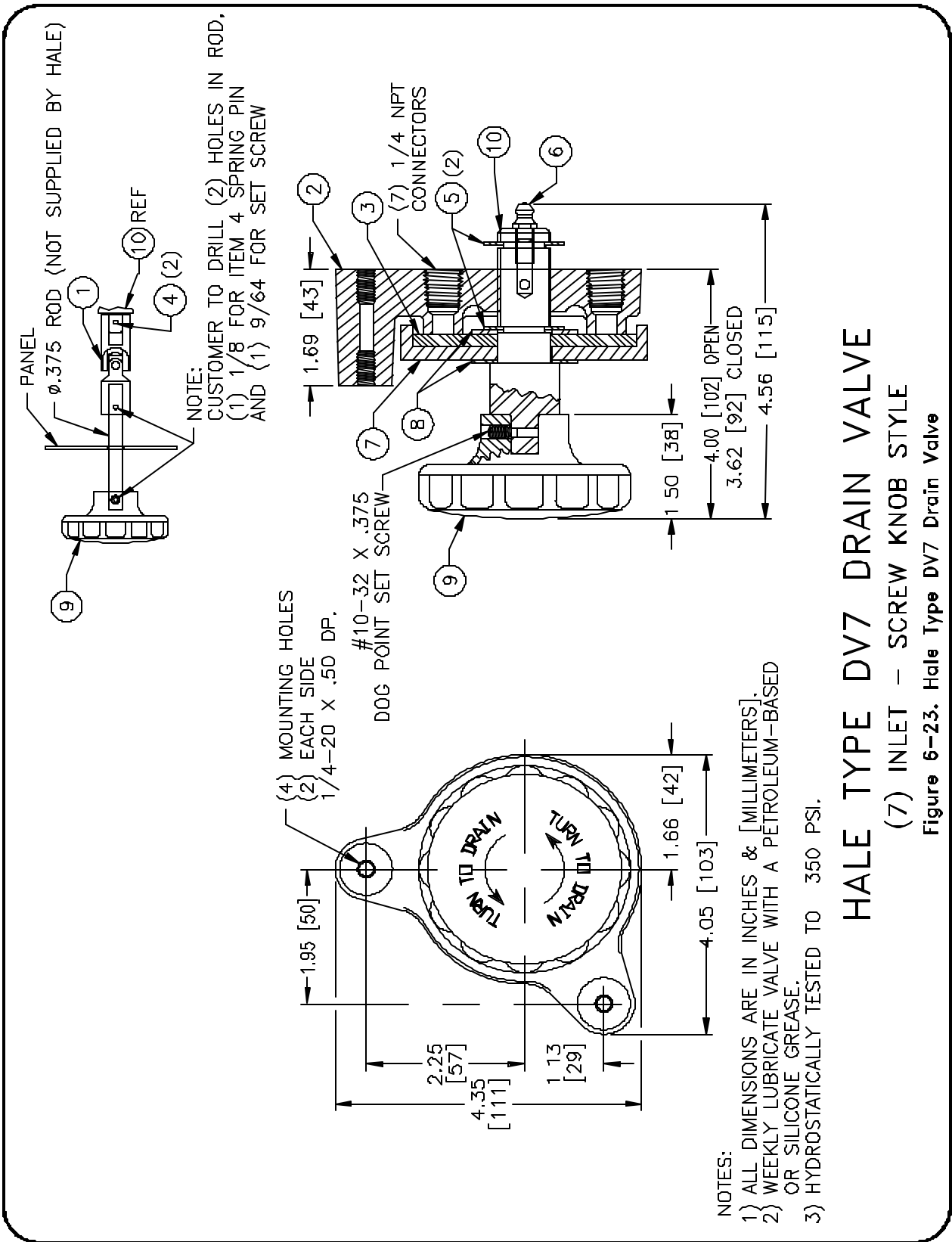



**PARTS LIST HALE TYPE VPS CONTROL VALVE  
FIGURE 6-24**

ITEM NO.	PART NO	QTY	DESCRIPTION
1	007-0080-01-0	1	Cylinder-Shift
2	018-1410-02-0	2	Screw-5/16-18 x 1 Lg. Hex Hd. Stl. Zinc Pl. Cap
3	018-1412-63-0	2	Screw-5/16-18 x 1-1/4 Lg. Soc. Hd. Stl. Flt. Pt. Zinc Pl. Set
4	018-1810-23-0	2	Screw-7/16-14 x 1 Lg. Counter-Bore 360° Nylon Lkg. Stl. Zinc Pl. Cap
5	037-1341-00-0	1	Shaft-Gearshift
6	040-0410-01-0	1	Ring-Cylinder Cover Seal
7	040-1139-03-0	1	Ring-Piston Inner Seal
8	040-2109-00-0	2	Ring-Gearshift Shaft Seal
9	040-3349-00-0	1	Ring-Piston Outer Seal
10	044-0210-01-0	1	Cover-Cylinder
11	046-5060-00-0	1	Gasket-Shifting Cylinder
12	073-0020-01-0	1	Piston-Cylinder
13	077-0750-05-0	2	Ring-Piston Retaining
14	110-1400-02-0	2	Nut-5/16-18 Zinc Pl. Stl. Hex
15	296-0020-00-0	1	Scraper-Gearshift Shaft

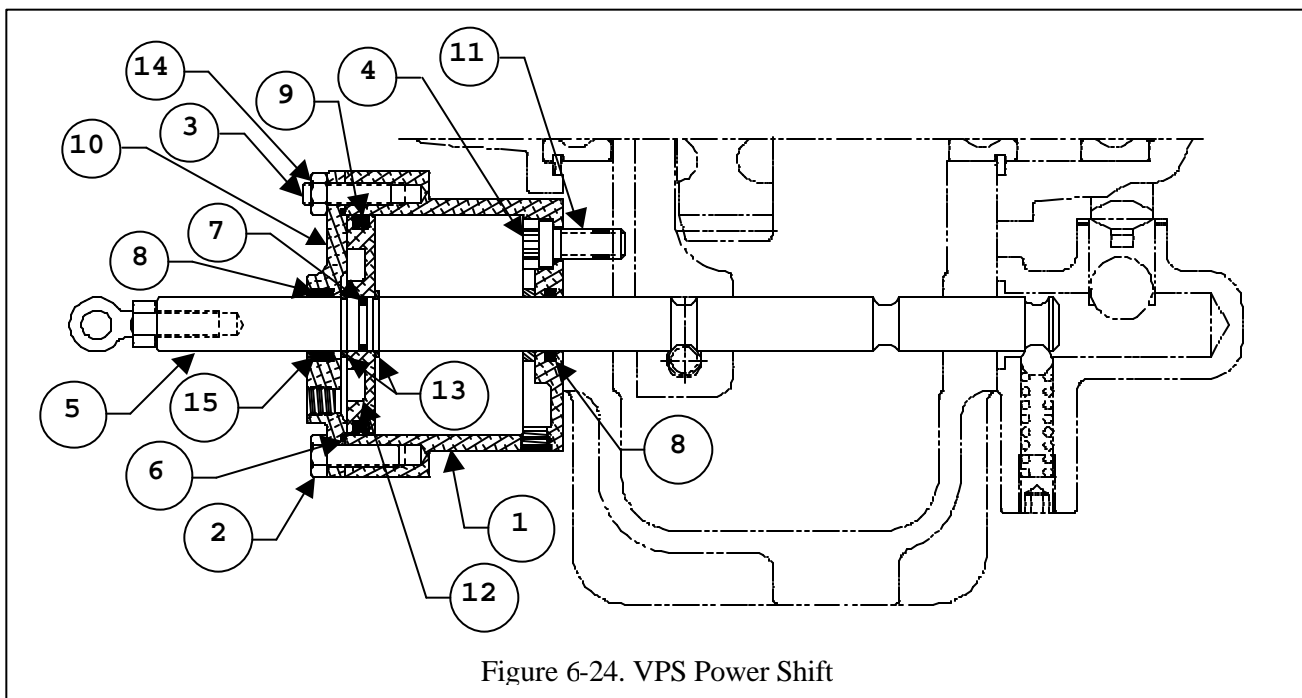

Figure 6-24. VPS Power Shift



---

<i>Atmospheric Pressure</i>	Pressure caused by the elevation of air above the earth.
<i>Auxiliary Cooling Valve</i>	Permits water from a pump to cool the radiator water through a heat exchange.
<i>Capacity</i>	Pump flow rating.
<i>Cavitation</i>	Caused by the pump attempting to deliver more water than is being supplied. This causes the formation of water vapor, and liquid water, under pressure, rushes in to fill the empty space. This damages the pump.
<i>Centrifugal Force</i>	Force that tends to make rotating bodies move away from the center of rotation.
<i>Centrifugal Pump</i>	A pump that uses a rapidly spinning disk to create the pressure for water movement.
<i>Certification</i>	Pumper test in accordance with NFPA standards to determine if a pump can deliver its rated volume and pressure.
<i>Check valve</i>	In two stage pumps, there are two swing check or flap valves in the suction passage of the second stage. They are located in each side of the pump between the suction tube and the pump body. These valves swing open when pumping in parallel for volume. They are closed by first stage pressure when pumping in series for pressure.
<i>Clearance Rings</i>	Prevent discharge water from returning to the eye of the impeller.
<i>Compound Gauge</i>	A compound gauge is graduated to read pressure in pounds per square inch and vacuum in inches of mercury.
<i>Double Suction Impeller</i>	Water enters on both sides of the impeller.
<i>Dry prime Test</i>	Provides information on the ability of a pump to evacuate air and draft water.
<i>Eye, Impeller</i>	Point where water enters the impeller.
<i>Flow Meter</i>	Measures the volume of water flowing.
<i>Friction Loss</i>	Loss of pressure in hose, fittings, standpipes, and other appliances because of the resistance between the water molecules and the inside surfaces of hoses, fittings, standpipes, and other appliances.
<i>Front-mount Pump</i>	Pump mounted ahead of the engine.

---



---

<i>Gauge Pressure</i>	Pressure read from a gauge (PSIG).
<i>Governor</i>	Minimizes pressure changes by controlling engine speed.
<i>Horsepower</i>	A measure of mechanical work.
<i>Impeller</i>	The working part of a centrifugal pump that, when rotating, imparts energy to water. Essentially, an impeller consists of two disks separated by curved vanes. The vanes force the water to move outward between the disks so that it is thrown outward at high velocity by centrifugal force.
<i>Net Pump Pressure</i>	The difference in pressure between discharge and suction pressure.
<i>Packing</i>	Material that maintains an airtight seal at point where the impeller shaft enters and exits the pump body.
<i>Parallel</i>	Capacity position in which each impeller on a two-stage pump works independently into the discharge.
<i>Pitot Gauge</i>	Measures velocity head at the discharge of a nozzle.
<i>Positive Displacement Pump</i>	A pump with a fixed flow delivered to the discharge with each revolution.
<i>Positive Pressure</i>	Pressure above atmospheric.
<i>Power Valve</i>	A valve that uses hydraulic pressure to transfer pump operation from volume to transfer pressure and vice versa.
<i>Pressure</i>	Force per unit area.
<i>Pressure Gauge</i>	The pressure gauge is usually graduated in pounds per square inch only. It is connected to the pump discharge manifold, thus indicating pump discharge pressure.
<i>Priming</i>	Priming evacuates the air from the main pump and suction hose, thus creating a vacuum. This allows atmospheric pressure on the source of water to push the water up into the suction hose and pump.
<i>Priming Pump</i>	A positive displacement pump that creates a vacuum to prime the main pump.
<i>Priming Valve</i>	A valve located in the priming line between the priming pump and the main pump. It remains closed at all times except when priming. The control is located on the pump panel.

---



---

<i>Pump Shift</i>	A midship pump is usually mounted with a split gearbox installed in the drive shaft. The pump shift moves a sliding gear in the gearbox that transmits power either to the pump or the rear axle. In road position, power is transmitted to the rear axle for driving; in pump position, the rear axle is disconnected, and power is transmitted to the pump shaft.
<i>Relay</i>	Movement of water from apparatus at a water source to additional apparatus until water reaches the fire ground.
<i>Relief Valve</i>	An automatic valve which, when activated by the relief valve control, will hold pump pressure steady when discharge valves or shutoff nozzles are closed. The valve maintains its given pressure by dumping the pump discharge flow into the pump suction.
<i>Relief Valve Control</i>	A handwheel adjustment valve which, set to control the desired pressure, will control the relief valve to maintain the working pressure.
<i>Series</i>	Pressure position in which the first impeller's discharge is fed to the eye of the second impeller in a two-stage pump which then discharges the water from the pump.
<i>Service Test</i>	Pump test performed to determine if the apparatus can deliver its rated volume and pressure.
<i>Shrouds</i>	Sides of an impeller that confine the water.
<i>Slinger Ring</i>	Prevents water from continuing to travel down a shaft to the gears and ball bearings.
<i>Stages</i>	The number of impellers in a pump that are used in series; that is, one following another in terms of flow. Each impeller develops part of the total pump pressure.
<i>Tachometer</i>	Indicates the speed of the engine crankshaft in revolutions per minute.
<i>Torque</i>	The force that acts to produce rotation.
<i>Transfer Valve</i>	A two-position valve in a pump that changes the operation from parallel (volume) to series (pressure) operation and vice versa (not used on single stage pumps).
<i>Vanes</i>	Guides inside an impeller that direct water to the volute.
<i>Volute</i>	Gradually increasing discharge waterway.
<i>Water Horsepower</i>	Amount of work that a pump can perform.
<i>Wear Rings</i>	See Clearance rings.

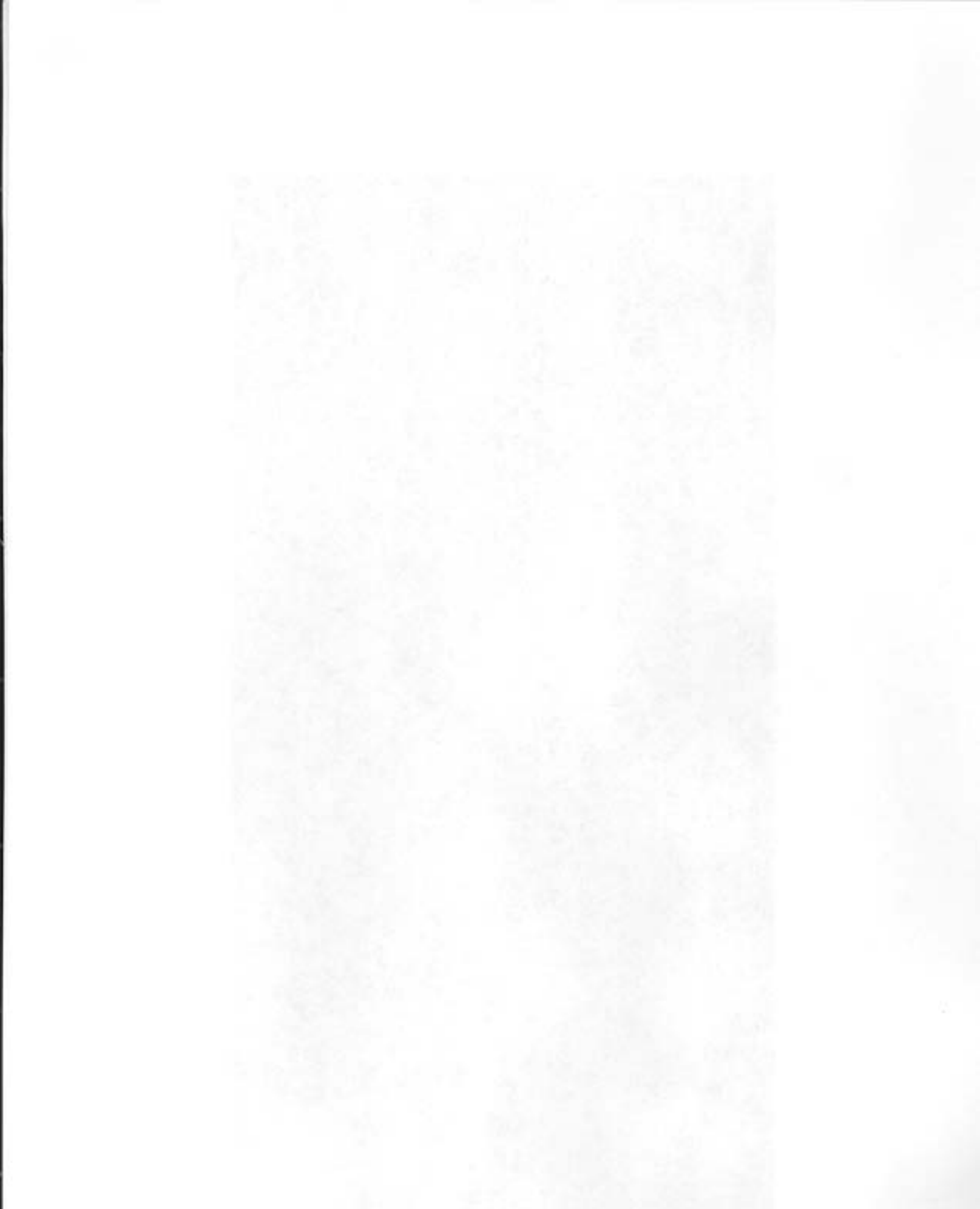



## APPENDIX A

WATER HORSE POWER=GALLONS PER MINUTE X TOTAL HEAD IN POUNDS PER SQUARE INCH

ONE GALLON OF WATER WEIGHS 8.33 POUNDS

ONE GALLON = 231 CUBIC INCHES

ONE CUBIC FOOT = 7.48 GALLONS

ONE POUND PER SQUARE INCH OF HEAD = 2.31 FEET OF WATER

ONE INCH OF MERCURY = 1.132 FEET OF WATER

ONE POUND PER SQUARE INCH = 2.0178 INCHES OF MERCURY = 27.68 INCHES OF WATER

POUNDS PER SQUARE INCH = FEET HEAD X .433

FEET HEAD = POUNDS PRESSURE X .231

ONE GALLON PER MINUTE X 3.785 = ONE LITER PER MINUTE

ONE CUBIC METER = 1000 LITER

ONE IMPERIAL GALLON = 1.2 GALLONS

ONE POUND PER SQUARE INCH X .0690 = ONE BAR = .001 KPA

### CONVERSIONS:

<u>TO CONVERT</u>	<u>TO</u>	<u>MULTIPLY BY</u>
GALLONS	LITERS	3.785
PSI	BARS	0.06895
BARS	PSI	14.504
Ft-Lb (Torque)	N-m	1.3558
HP	KW	0.7457





## Limited Warranty

---

**EXPRESS WARRANTY:** Hale Products Inc. ("Hale") hereby warrants to the original buyer that products manufactured by it are free of defects in material and workmanship for two (2) years or 2000 hours usage whichever shall first occur. The "Warranty Period" commences on the date the original buyer takes delivery of the product from the manufacturer.

**LIMITATIONS:** HALE'S obligation is expressly conditioned on the Product being:

- Subjected to normal use and service.
- Properly maintained in accordance with HALE'S Instruction Manual as to recommended services and procedures.
- Not damaged due to abuse, misuse, negligence or accidental causes.
- Not altered, modified, serviced (non-routine) or repaired other than by an Authorized Service Facility.
- Manufactured per design and specifications submitted by the original Buyer.

**THE ABOVE EXPRESS LIMITED WARRANTY IS EXCLUSIVE. NO OTHER EXPRESS WARRANTIES ARE MADE. SPECIFICALLY EXCLUDED ARE ANY IMPLIED WARRANTIES INCLUDING, WITHOUT LIMITATIONS, THE IMPLIED WARRANTIES OF MERCHANTABILITY OF FITNESS FOR A PARTICULAR PURPOSE OR USE; QUALITY; COURSE OF DEALING; USAGE OF TRADE; OR PATENT INFRINGEMENT FOR A PRODUCT MANUFACTURED TO ORIGINAL BUYER'S DESIGN AND SPECIFICATIONS.**

**EXCLUSIVE REMEDIES:** If Buyer promptly notifies HALE upon discovery of any such defect (within the Warranty Period), the following terms shall apply:

- Any notice to HALE must be in writing, identifying the Product (or component) claimed defective and circumstances surrounding its failure.
- HALE reserves the right to physically inspect the Product and require Buyer to return same to HALE'S plant or other Authorized Service Facility.
- In such event, Buyer must notify HALE for a Returned Goods Authorization number and Buyer must return the Product F.O.B. within (30) days thereof.
- If determined defective, HALE shall, at its option, repair or replace the Product, or refund the purchase price (less allowance for depreciation).
- Absent proper notice *within* the Warranty Period, HALE shall have no further liability or obligation to Buyer therefore.

**THE REMEDIES PROVIDED ARE THE SOLE AND EXCLUSIVE REMEDIES AVAILABLE. IN NO EVENT SHALL HALE BE LIABLE FOR INCIDENTAL OR CONSEQUENTIAL DAMAGE' INCLUDING, WITHOUT LIMITATION, LOSS OF LIFE; PERSONAL INJURY; DAMAGE TO REAL OR PERSONAL PROPERTY DUE TO WATER OR FIRE; TRADE OR OTHER COMMERCIAL LOSSES ARISING, DIRECTLY OR INDIRECTLY, OUT OF PRODUCT FAILURE.**



Hale Products Inc. • A Unit of IDEX Corporation  
700 Spring Mill Avenue • Conshohocken, PA. 19428  
Phone: 610-825-6300 • Fax: 610-825-6440  
[www.haleproducts.com](http://www.haleproducts.com)



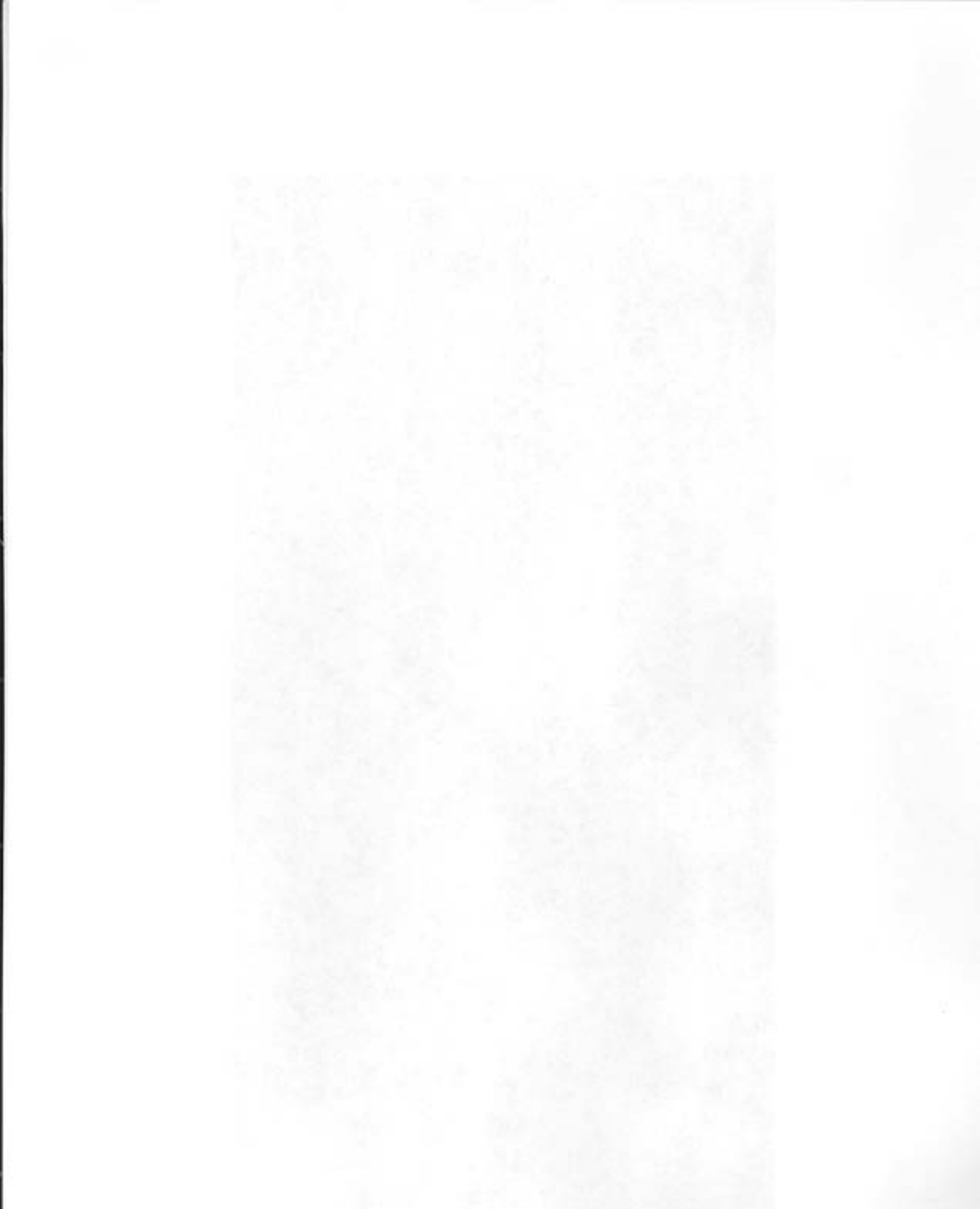



## Hale Products Factory Authorized Service Centers

Hale's Factory Authorized Service Centers are ready to service your pump with factory trained mechanics and a stock of parts to ensure that your apparatus is ready for action. Contact a dealer near you for quick, dependable service.

### ALABAMA

#### Harless Fire Equipment

P O Box 671  
1166 Faimund Muscoda  
Bessemer, AL 35020  
205-425-1160

#### North American Fire ☎

1515 West Moulton Street  
Decatur, AL 35601  
256-353-7100

### ARIZONA

#### United Fire Equipment ☎

335 N. 4 th Avenue  
Tucson, AZ 85705  
520-622-3639

### CALIFORNIA

#### Burton's Fire Apparatus

1301 Doker Drive, Building B  
Modesto, CA 95351  
209-544-3161

#### Hi-Tech E.V.S. Inc. ☎

444 W. Greger Street  
Oakdale, CA 95361  
209-847-3042

#### KME West

2831 E. Philadelphia  
Ontario, CA 91761  
909-937-3326

#### Los Angeles Freightliner

1049A South Vineyard Ave.  
Ontario, CA 91761  
909-606-9100

### CONNECTICUT

#### American LaFrance of N.E.

199 Roberts St.  
East Hartford, CT 06108  
(860) 610-6202

### DELAWARE

#### Delmarva American LaFrance

335 Strauss Ave ☎  
Marydel, DE 19964  
302-492-1245

### FLORIDA

#### Elite Fire & Safety Equipment ☎

3573 Enterprise Ave. #64  
Naples, FL 33942  
800-432-3626

#### Municipal Equipment ☎

1124 S. Woods Avenue  
Orlando, FL 32805  
407-843-3071

#### Ten-8 Fire Equipment ☎

2904 - 59 Avenue Drive E  
Bradenton, FL 34203  
941-756-7779

### GEORGIA

#### Fireline Inc.

385A Frammer Court  
Lawrenceville, GA 30045  
770-682-4446

#### Fouts Bros. Fire Equipment

2158 Atlanta Street  
Smyrna, GA 30080  
770-433-0112

#### Southern Fire

P O Box 512  
Jasper, GA 30143  
706-692-7319

### ILLINOIS

#### Alexis Fire Apparatus

109 East Broadway  
Alexis, IL 61412  
309-482-6121

#### Mid America Truck & Equip.

625 South Route 83  
Elmurst, IL 60126  
630-834-7300

#### Towers Fire Apparatus

502 S. Richland St.  
Freeburg, IL 62243  
618-539-3863

#### Banner Fire Equipment

4601 Hedge Road  
East Alton, IL 62024  
618-251-4200

### INDIANA

#### Hoosier Fire Equipment

4009 Montdale Park Drive  
Valparaiso, IN 46383  
219-462-1707

#### WSF Emergency Vehicle Repair and Maintenance

10677 Old Boon Highway  
Chandler, IN 47610  
812-925-7595

### IOWA

#### Toynes Fire Truck ☎

East Main, Box 16  
Breda, IA 51436  
712-673-2328

#### Conrad Fire Equipment

887 North Jan-Mar Court  
Olathe, KS 66061  
913-780-5521

### LOUISIANA

#### Casco Industries

P O Box 8007  
Shreveport, LA 71148  
318-865-5107

### Southland Fire & Safety

1918 S. Southland Avenue  
Gonzales, LA 70737  
504-621-3473

### MASSACHUSETTS

#### Greenwood Fire Apparatus ☎

530 John Dietsch Blvd.  
North Attleboro, MA 02763-1080  
508-695-7138

### MAINE

#### Reliance Equipment

RR1, Box 211  
Box 6622B  
Vaassalboro, ME 04989  
207-626-0075

### MICHIGAN

#### Apollo Fire ☎

12584 Lakeshore Dr.  
Romeo, MI 48065  
810-752-1800

#### Front Line Services

8588 Carter Road  
Freeland, MI 48623  
517-695-6633

#### West Shore Services Inc.

620 Lake Michigan Drive  
P. O. Box 188  
Allendale, MI 49401  
616-895-4347

### NEW JERSEY

#### Tasc Fire Apparatus

5012 Industrial Road  
Farmingdale, NJ 07727  
732-938-3393

#### Fire & Safety Services

50 Shelton Road  
Piscataway, NJ 08854  
732-752-2400

### NEW MEXICO

#### Artesia Fire Equipment

1014 South First Street  
P. O. Box 1367  
Artesia, NM 88210  
505-746-2426

Hale Products, A Unit of IDEX Corp, 700 Spring Mill Avenue, Conshohocken, PA 19428  
TEL: 610/825-6300 FAX: 610/825-9615 Rev 10/02. Visit our Internet site at: [www.haleproducts.com](http://www.haleproducts.com)

☎ = 24 Hour Emergency Paging Service



## Hale Products Factory Authorized Service Centers

Hale's Factory Authorized Service Centers are ready to service your pump with factory trained mechanics and a stock of parts to ensure that your apparatus is ready for action. Contact a dealer near you for quick, dependable service.

### NEW YORK

#### Churchville Fire Equipment ☎

340 Sanford Road  
Churchville, NY 14428  
716-293-1688

#### Firematic Supply Co. ☎

10 Ramsay Road  
Shirley, NY 11967  
631-924-3181

#### Garrison Fire & Safety ☎

Route 23A, Main St.  
Palenville NY 12463  
518-678-2281

#### Har-Rob Fire Apparatus ☎

519 Liberty Street  
Syracuse, NY 13204  
315-422-0730

#### Hendrickson Truck Center

1026 E. Jericho Turnpike  
Huntington Station, NY 11788  
631-424-8354

#### Nassau Fire Apparatus Service ☎

67 Albany Avenue  
Amityville, NY 11701  
631-789-2205

#### Nichols Fire Apparatus ☎

P. O. Box 651  
Hyde Park, NY 12538  
845-229-8181

### NORTH CAROLINA

#### C.W. Williams Company

501 Instrument Drive  
P O Box 7757  
Rocky Mount, NC 27804  
919-977-9241

#### Triad Transportation Sales c/o West Carolina Freightliner

6712 Freedom Drive  
Charlotte, NC 28214  
877-815-1925

### OHIO

#### American National Fleet Service

7714 Commerce Park Oval ☎  
Independence, OH 44131  
866-353-3863

#### Cummins-Bridgeway LLC

2297 Southwest Blvd, Suite K  
Grove City, OH 43123  
248-573-1600

#### Finley Fire Equipment

20 South 5th St.  
McConnelsville, OH 43756  
740-962-4328

### Sutphen Corporation

7000 Marysville Road  
Amlin, OH 43002  
614-889-1005

### OKLAHOMA

#### Chief Fire & Safety

927 South 4th Street  
Chickasha, OK 73018  
405-224-2596

### PENNSYLVANIA

#### East Penn Fire & Emergency ☎

P. O. Box 299  
Pottsville, PA 17901  
570-429-1016

#### Glick Fire Equipment ☎

307 Airport Drive  
Smoketown, PA 17576  
717-299-4120

#### Guardian Fire Equipment ☎

215 E. Hancock St.  
Lansdale, PA 19446  
215-855-2000

#### Halo Srevice Company

9 Jackson Avenue  
Collingdale, PA 19023  
610-237-0619

#### Honesdale Fire Equipment ☎

140 Grandview Avenue  
Honesdale, PA 18431  
570-253-5037

#### Kaza Fire Equipment ☎

155 Lovell Avenue  
Suite 1  
Ebensburg, PA 15931  
814-472-8650

### SOUTH CAROLINA

#### Jack Slagle Fire Equipment

P O Box 21984  
Cayce, SC 29171  
803-791-4555

### TENNESSEE

#### Fire Apparatus Services

115 Haywood Lane  
Antioch, TN 37011  
615-833-9031

### TEXAS

#### Fire Apparatus Specialist

1215 Mississippi  
South Houston, TX 77587  
713-941-0909

### VIRGINIA

#### American Fire Equip.

13720 Dabney Road  
Woodbridge, VA 22191  
703-491-2990

#### Jack L. Slagle Fire Equip. & Supply Co. ☎

1100 Bill Tuck Highway  
South Boston, VA 24592  
434-575-7905

#### Vestis Sales and Service Inc.

1185 Stonwall Road NE  
Check, VA 24072  
540-651-8452

### WASHINGTON

#### United Fire Service ☎

1500 19th Ave NW  
Issaquah, WA 98027  
425-392-1622

### WEST VIRGINIA

#### All-American Fire Equipment ☎

3253 US Route 60 East  
P. O. Box 146  
Ona, WV 25545  
304-733-3581

### WISCONSIN

#### Rennerts Fire Equipment ☎

615 East John St.  
Marksean, WI 53946  
920-398-1033

### CANADA

#### Aero-Feu, Ltd

615 Blvd. Guimond  
Industrial Park  
Longueuil, PQ  
Canada J4G 1L9  
450-651-2240

#### Darch Fire

9-402 Harmony Road  
R.R. #1  
Ayr, Ontario, Canada  
N0B 1E0  
519-622-6110

#### Phoenix Emmergency Vehicles

#5 7870 - 48th Avenue  
Red Deer, AB, Canada  
T4P 2B2  
403-347-7045

#### Profire Emergency Equipment

30686-A South Fraser Way  
Abbotsford, BC, Canada  
V2T 6L4  
604-852-2510



# Pro ♦ Tech

---

**MAXIMUM WARRANTY**

*Let Us Put Out A Few Fires For You.*



# Fighting Fires Is Your Business. Looking Out For Your Pump Is Ours.

Few things in life are more reliable than your new Hale midship pump. We do our best to keep it that way, too, with our standard two-year/2,000-hour warranty.

Now we're going ourselves one better, with an extended warranty that can keep your Hale midship pump covered for up to five whole years.

We call it the Pro•Tech Maximum Warranty. It's an exceptional value in long-term protection and peace of mind.

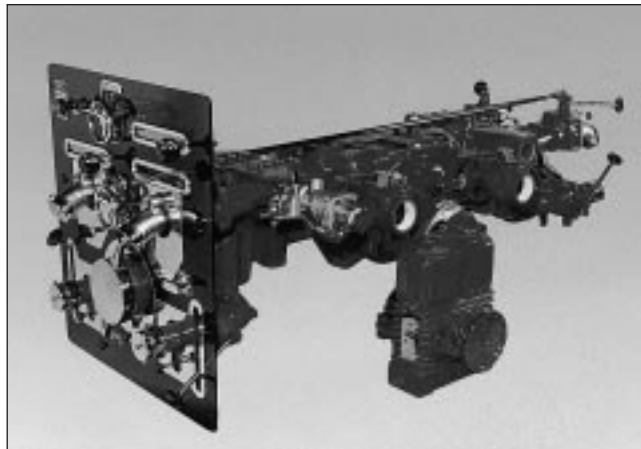

## Buy More, Pay Less.

With the Pro•Tech Maximum Warranty, you can choose your own coverage in one-year increments. And the longer your coverage, the lower your annual cost.

You can buy one year for \$350, two years for \$675, or three years for \$1,000.

Whichever term you choose, you'll get the same coverage that makes our standard warranty great — and lots more time to make the most of it. (For details, check the actual Limited Warranty text on the next page.)

## There's A Sixty-Day Deadline.

Strong as the Pro•Tech Maximum Warranty is, it's only as good as your commitment to maintaining and caring for your new Hale pump. So we must ask you to begin that process by committing to an extended warranty within sixty days of placing your new pump in service.

Just complete the form on the opposite page, tear it off, fold it as indicated, and return it to us with your check. Keep the upper portion for your records.

And if you have any questions, please feel free to call us at 610/825-6300 — and ask for our Warranty Department.

### Warranty Coverage

**Standard,  
No-Charge  
Warranty**

Two Years/2,000 Hours

**Extended  
Warranty  
Plans**

One Year/1,000 Hours  
Two Years/2,000 Hours  
Three Years/3,000 Hours

**Total  
Available**

Five Years/5,000 Hours

## Keep This Portion For Your Records.

Pump Model #: \_\_\_\_\_

Pump Serial #: \_\_\_\_\_

Dealer Purchased From: \_\_\_\_\_

Date: \_\_\_\_\_

Apparatus Manufacturer: \_\_\_\_\_

Date Placed In Service: \_\_\_\_\_

**Express Warranty:** In addition to the standard two-year/2,000-hour limited warranty provided at no charge, Hale Products, Inc. ("Hale") hereby warrants to the original buyer that split-shaft midship type pumps manufactured by it are free of defects in material and workmanship for the additional warranty period selected. The

extended warranty period commences two (2) years after the date the Product is first placed in service — that is, upon the date on which the standard warranty expires. The length of the extended warranty period (one year/1,000 hours, two years/2,000 hours, or three years/3,000 hours) shall be as selected and purchased by the original buyer of the product.

**Limitations:** Hale's obligation is expressly conditioned on the Product being

- Subjected to normal use and service;
- Properly maintained in accordance with Hale's Instruction Manual and the Hale Midship Recommended Maintenance List as to recommended services and procedures (documentation may be required);
- Not damaged due to abuse, misuse, negligence or accidental causes;
- Not altered, modified, serviced (non-routine) or repaired other than by an Authorized Service Facility;
- Manufactured per design and specifications submitted by the original Buyer.

(Continued on other side.)



## Midship Pump Registration Form

Complete and return (with your check payable to Hale Products, Inc.) to the address below.

### Equipment Description

Pump Model #: \_\_\_\_\_

Pump Serial #: \_\_\_\_\_

Dealer Purchased From: \_\_\_\_\_

Dealer Salesman: \_\_\_\_\_

Date: \_\_\_\_\_

Apparatus Manufacturer: \_\_\_\_\_

Engine Model: \_\_\_\_\_

Transmission Model: \_\_\_\_\_

Date Placed In Service: \_\_\_\_\_

### Vehicle Type (check one):

- Pumper       Aerial       Tanker  
 Tanker Pumper       Mini Pumper       Rescue Pumper

### Purchasing Company/Department

Name: \_\_\_\_\_

Street: \_\_\_\_\_

City: \_\_\_\_\_ County: \_\_\_\_\_

State: \_\_\_\_\_ Country: \_\_\_\_\_

Zip/Postal Code: \_\_\_\_\_

Authorized Signature: \_\_\_\_\_

Today's Date: \_\_\_\_\_

### Extended Warranty Period/Payment Enclosed (check one):

- Two years/2,000 hours — No Charge  
 Additional One year/1,000 hours — \$350  
 Additional Two years/2,000 hours — \$675  
 Additional Three years/3,000 hours — \$1,000

HALE PRODUCTS, INC. • 700 Spring Mill Avenue • Conshohocken, PA 19428

(Continued from other side.)

THIS EXPRESS LIMITED WARRANTY IS EXCLUSIVE. NO OTHER EXPRESS WARRANTIES ARE MADE. SPECIFICALLY EXCLUDED ARE ANY IMPLIED WARRANTIES, INCLUDING WITHOUT LIMITATION, THE IMPLIED WARRANTIES OF MERCHANTABILITY; FITNESS FOR A PARTICULAR PURPOSE OR USE; QUALITY; COURSE OF DEALING; USAGE OF TRADE; OR PATENT INFRINGEMENT FOR A PRODUCT MANUFACTURED TO ORIGINAL BUYER'S DESIGN AND SPECIFICATIONS.

Exclusive Remedies: If Buyer promptly notifies Hale upon discovery of any such defect (within the Warranty Period), the following terms shall apply:

- Any notice to Hale must be in writing, identifying the Product (or component) claimed defective and circumstances surrounding its failure;
- Hale reserves the right to physically inspect the Product and require Buyer to return same to Hale's plant or other Authorized Service Facility;
- In such event, Hale will provide a Returned Goods Authorization and Buyer must return the Product F.O.B. within thirty (30) days thereof;

- If determined defective, Hale shall, at its option, repair or replace the Product, or refund the purchase price (less allowance for depreciation);
- Absent proper notice within the Warranty Period, Hale shall have no further liability or obligation to Buyer therefore.

THE REMEDIES PROVIDED ARE THE SOLE AND EXCLUSIVE REMEDIES AVAILABLE. IN NO EVENT SHALL HALE BE LIABLE FOR INCIDENTAL OR CONSEQUENTIAL DAMAGES INCLUDING, WITHOUT LIMITATION, LOSS OF LIFE; PERSONAL INJURY; DAMAGE TO REAL OR PERSONAL PROPERTY DUE TO WATER OR FIRE; LOSS OF TIME OR USE OF THE PRODUCT; INCONVENIENCE; TRADE OR OTHER COMMERCIAL LOSSES ARISING, DIRECTLY OR INDIRECTLY, OUT OF THE PRODUCT FAILURE.

## *Hale Products, Inc.*

700 Spring Mill Ave.  
Conshohocken, PA 19428

TEL: (610) 825-6300  
FAX: (610) 825-6440



**HALE PRODUCTS INC.** A Unit of IDEX Corporation

700 Spring Mill Ave. • Conshohocken, PA • USA • 19428  
TEL: (610) 825-6300 • FAX: (610) 825-6440

